

Whatcom County

2005-2006 Final Budget



Recipient of the 2004
GFOA Distinguished
Budget Presentation
Award

Volume 2
Department
Budgets

Pete Kremen
County Executive

Whatcom County 2005-2006 Final Budget

Volume 2

Department Budgets

Whatcom County 2005-2006 Final Budget

County Executive
Pete Kremen

Prepared by the
Administrative Services Department

Director
Dewey Desler

Administrative Assistant
Linda Harduar

Finance Manager
Brad Bennett

Budget Staff
Marianne Caldwell
Kristin Frank
Kellie Eiswald

Graphic Design
Eva Browning



GOVERNMENT FINANCE OFFICERS ASSOCIATION

*Distinguished
Budget Presentation
Award*

PRESENTED TO

**Whatcom County
Washington**

For the Fiscal Year Beginning

January 1, 2004

President

Executive Director

The Government Finance Officers Association of the United States and Canada (GFOA) presented a Distinguished Budget Presentation Award to Whatcom County, Washington for its annual budget for the fiscal year beginning January 1, 2004. In order to receive this award, a governmental unit must publish a budget document that meets program criteria as a policy document, as an operations guide, as a financial plan, and as a communications device.

This award is valid for a period of one year only. We believe our current budget continues to conform to program requirements, and we are submitting it to GFOA to determine its eligibility for another award.

For inquiries regarding this document contact:

Whatcom County Administrative Services, Finance Division
311 Grand Avenue
Suite 503
Bellingham, WA 98225

360.676.6734 extension 50557

On the cover:
Hale Passage
Photo by Eva Browning

Table of Contents - Volume 2

Administrative Services Department **1**

Organizational Chart	1
Mission & Objectives	2
Expenditure Trends	5
Budget by Program	6
Program Summary	7
Funding Sources	8
Performance / Activity Measures	10
Expenditures Summary	12
Services	15

County Assessor **19**

Organizational Chart	19
Mission & Objectives	20
Expenditure Trends	21
Budget by Program	22
Program Summary	23
Funding Sources	24
Performance / Activity Measures	25
Expenditures Summary	26
Services	27

County Auditor **29**

Organizational Chart 29
 Mission & Objectives 30
 Expenditure Trends 32
 Budget by Program 33
 Program Summary 34
 Funding Sources 35
 Performance / Activity Measures 36
 Expenditures Summary 38
 Services 40

County Council **41**

Organizational Chart 41
 Mission & Objectives 42
 Expenditure Trends 43
 Budget by Program 44
 Program Summary 45
 Funding Sources 46
 Performance / Activity Measures 47
 Expenditures Summary 48
 Services 49

District Court **51**

Organizational Chart 51
 Mission & Objectives 52
 Expenditure Trends 53
 Budget by Program 54
 Program Summary 55
 Funding Sources 56
 Performance / Activity Measures 57
 Expenditures Summary 58
 Services 59

District Court Probation 61

Mission & Objectives	62
Expenditure Trends	64
Budget by Program	65
Program Summary	66
Funding Sources	67
Performance / Activity Measures	68
Expenditures Summary	69
Services	70

County Executive 71

Organizational Chart	71
Mission & Objectives	72
Expenditure Trends	73
Budget by Program	74
Program Summary	75
Funding Sources	76
Expenditures Summary	77
Services	78

Non-Departmental 79

Expenditure Trends	80
Budget by Program	81
Program Summary	82
Funding Sources	84
Expenditures Summary	86
Services	91

Extension 95

Organizational Chart	95
Mission & Objectives	96
Expenditure Trends	98
Budget by Program	99
Program Summary	100
Funding Sources	101
Performance / Activity Measures	102
Expenditures Summary	103
Services	104

Health & Human Services 105

Organizational Chart	105
Mission & Objectives	106
Expenditure Trends	108
Budget by Program	109
Program Summary	110
Funding Sources	111
Performance / Activity Measures	113
Expenditures Summary	116
Services	118

Hearing Examiner 121

Organizational Chart	121
Mission & Objectives	122
Expenditure Trends	123
Budget by Program	124
Program Summary	125
Funding Sources	126
Performance / Activity Measures	127
Expenditures Summary	128
Services	129

Juvenile Court Administration 131

Organizational Chart	131
Mission & Objectives	132
Expenditure Trends	134
Budget by Program	135
Program Summary	136
Funding Sources	138
Performance / Activity Measures	139
Expenditures Summary	140
Services	144

Parks and Recreation Department 145

Organizational Chart	145
Mission & Objectives	146
Expenditure Trends	149
Budget by Program	150
Program Summary	151
Funding Sources	152
Performance / Activity Measures	153
Expenditures Summary	155
Services	158

Planning & Development Services 159

Organizational Chart	159
Mission & Objectives	160
Expenditure Trends	164
Budget by Program	165
Program Summary	166
Funding Sources	167
Performance / Activity Measures	168
Expenditures Summary	170
Services	173

Prosecuting Attorney 175

Organizational Chart	175
Mission & Objectives	176
Expenditure Trends	178
Budget by Program	179
Program Summary	180
Funding Sources	181
Performance / Activity Measures	183
Expenditures Summary	184
Services	186

Public Defender 187

Organizational Chart	187
Mission & Objectives	188
Expenditure Trends	189
Budget by Program	190
Program Summary	191
Funding Sources	192
Performance / Activity Measures	193
Expenditures Summary	194
Services	195

Public Works Department 197

Organizational Chart	197
Mission	198
Objectives	199
Expenditure Trends	204
Budget by Program	205
Program Summary	206
Funding Sources	207
Performance / Activity Measures	209
Expenditures Summary	213
Services	216

County Sheriff 221

Organizational Chart 221
Mission & Objectives 222
Expenditure Trends 224
Budget by Program 225
Program Summary 226
Funding Sources 228
Performance / Activity Measures 229
Expenditures Summary 230
Services 234

Sheriff - Jail 237

Organizational Chart 237
Mission & Objectives 238
Expenditure Trends 239
Budget by Program 240
Program Summary 241
Funding Sources 242
Performance / Activity Measures 244
Expenditures Summary 245
Services 248

Superior Court / Superior Court Clerk's Office 249

Organizational Chart 249
Mission & Objectives 250
Expenditure Trends 251
Budget by Program 252
Program Summary 253
Funding Sources 254
Performance / Activity Measures 255
Expenditures Summary 256
Services 258

County Treasurer 263

Organizational Chart 263
 Mission & Objectives 264
 Expenditure Trends 265
 Budget by Program 266
 Program Summary 267
 Funding Sources 268
 Performance / Activity Measures 269
 Expenditures Summary 270
 Services 271

Veteran’s Relief 273

Mission & Objectives 274
 Expenditure Trends 275
 Budget by Program 276
 Program Summary 277
 Funding Sources 278
 Expenditures Summary 279

For General Information, Summaries and Appendices, see Volume 1

Administrative Services Department

Administrative Services is an internal service department that provides a variety of support services, such as maintenance and custodial service, accounting, payroll, employee benefits, and information systems support to county departments and agencies. Divisions of Administrative Services are Facilities Management, Finance, Human Resources and Information Services.

FTE's for this department

Year	2001	2002	2003	*2004	*2005	*2006
FTE	60.25	60.25	60.75	67.45	68.95	67.35

**budget*

The chart below shows the organizational structure for 2005 only.

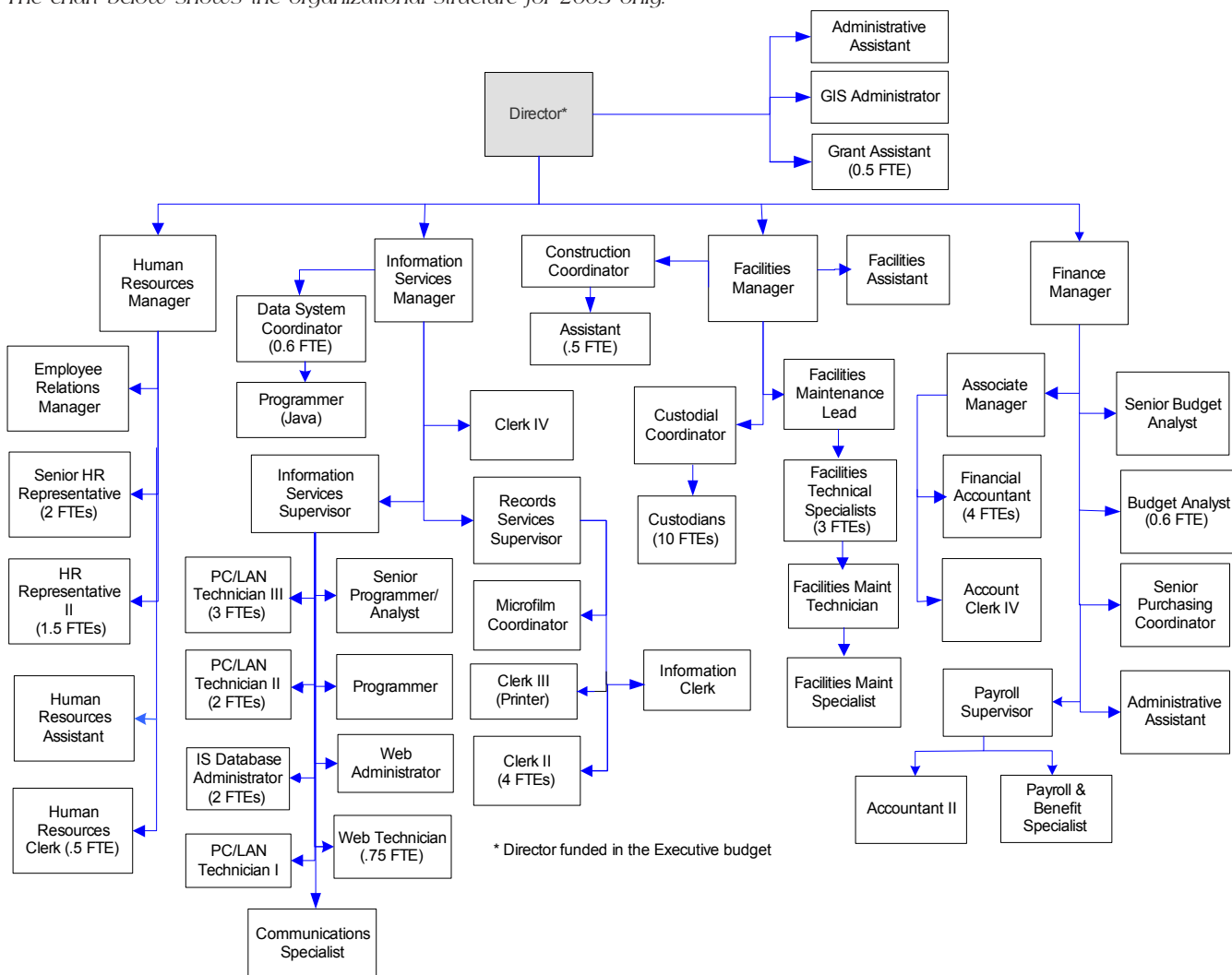

Mission & Objectives

Mission

Provide high quality support to county departments so that citizens of Whatcom County receive responsive, efficient, cost-effective government services. The components of Administrative Services (AS) include Administration, Facilities, Finance, Human Resources, Information Services and Geographical Information Systems Administration.

Objectives

Administration

- Hold weekly meetings with Administrative Services (AS) Managers.
- Meet quarterly with AS Managers as a group to share ideas and suggestions on ways to improve services to all departments.
- Complete new Administrative Policies & Procedures for AS Department through AS-Policy Writing Group. Review and revise Policies & Procedures submitted by County departments.
- Complete the Master Facility Plan for Whatcom County, recommend and, as appropriate, initiate next phases of the plan implementation.
- Grant assistant will continue learning about the Community Development Block Grant Program and evaluate the County's involvement in expanded use of these grants.
- Evaluate the Economic Development Investments (EDI) Program.
- Meet with departments to analyze the success of the biennial budget process.

- Implement an Enterprise Geographic Information System (GIS) in Whatcom County.
- Meet monthly with policy/steering committee to set course for Whatcom County GIS.
- Meet monthly with technology committee to assist with technological concerns and plan for the future needs of GIS in Whatcom County.
- Develop internal communication strategy to be used throughout the county for GIS.
- Develop, share, and recommend GIS training standards.
- Review GIS staffing needs.
- Develop GIS data standards and protocols.
- Oversee construction activities surrounding the new minimum security jail project.

Facilities Management

- Continue development of the preventive maintenance repair program for county building mechanical equipment. This program will enable Facilities Management staff to make repairs before problems escalate and become significantly more costly.
- Continue ongoing safety/security reviews of all county facilities on a daily basis and implement necessary corrections, repairs and/or modifications.
- Enhance staff education/training/service levels by providing more training opportunities with building operations, security systems, HVAC building automation system, customer service, project and time management and other training as it relates to the day to day tasks of Facilities Management.

Objectives continued

- Continue evaluation of our maintenance and custodial services on a quarterly basis, review and implement new procedures as necessary throughout all Whatcom County facilities.
- Provide ongoing training on an annual basis for Facilities Management staff for procedures to be followed in responding to emergency situations, such as: which utilities to turn off and which to leave operational, when to evacuate facilities, what agencies to notify.
- Continue to work with all county departments to coordinate all remodel and construction projects as requests and needs arise.
- Issue 26 county payrolls and 12 district payrolls accurately and on time.
- Document and issue 61,500 warrants in compliance with all legal requirements, resulting in no audit discrepancies.
- Administer 150 bids in compliance with all legal requirements.
- Issue 1099's and W2's within federal deadlines.
- Issue four quarterly financial reports within 45 days of the end of each quarter.
- Administer fixed asset tracking system and perform annual inventory.

Finance

- Scan invoices into the organization-wide imaging system (LaserFiche) and develop an application that will integrate the image data into our existing accounts payable system.
- Scan contracts into LaserFiche and develop a searchable database application.
- Develop and implement a grant database application.
- Provide grant accounting procedure training to departments that receive grants.
- Develop and publish accounts payable and payroll web pages to our intranet.
- Integrate financial projections into Whatcom County's long term capital projects planning.
- Develop a network database application to create and manage supplemental budget requests.
- Coordinate biennial budget preparation and present to the County Council in accordance with county charter.
- Issue budget status reports by the 15th of each month.
- Earn the Government Finance Officers Association (GFOA) Distinguished Budget Presentation Award for the biennial budget.
- Earn the GFOA Certificate of Achievement for Excellence in Financial Reporting for the comprehensive annual financial reports.
- Conduct two payroll preparer "user" meetings and two claims preparer "user" meetings.

Human Resources

- Complete transition to new workers' compensation administrator.
- Negotiate collective bargaining agreements which expire 12/31/04:
 - IFPTE - Local 17
 - Master (Teamsters)
 - Health Clerical (Teamsters)
 - Wa State Nurses Assoc

Objectives continued

- Complete negotiations for any pending collective bargaining agreements still open 12/31/04:
 - a) Deputy Sheriffs' Guild
 - b) Corrections Officers
 - Consider RFP processes and negotiate administrative contracts with service providers:
 - a) Professional Labor Negotiator
 - b) Deferred Compensation Plan
 - Redraft personnel administrative policies and procedures to incorporate changes dictated by law and county business needs into plain English format.
 - Identify and meet priority supervisory training needs using methods to most effectively meet those needs.
 - Strengthen county management and operations and maintain critical knowledge and skills through organizational development opportunities.
 - Contain rate of increase to benefit costs and streamline benefit programs to address county financial situation while maintaining effective recruitment and retention tools.
 - Create Human Resources Internet and intranet resources for internal and external customers.
 - Reduce legal liability through prompt and effective investigation of complaints and workplace issues.
- Information Services**
- Finalize and publish policies and procedures identified in the Security and Governance Technical Audit.
 - Partner with AS-GIS to roll out enterprise GIS system.
 - Add new on-line forms via WIRE and the public website to assist departments in enhancing service to employees and the public.
 - Implement electronic business solutions to assist in bringing government to the citizens of Whatcom County.
 - Complete Phase I of the Law and Justice Data Integration Project.
 - Improve service levels to all departments in all areas of responsibility.
 - Conduct at least five sets of in-house training sessions for county employees on standardized software and Internet usage.
 - Complete installation of LaserFiche in the six departments given funding in the 2004 budget and begin installation in those departments approved for funding in the 2005 budget process.
 - Draft and publish policies and procedures for LaserFiche use.
 - Apply budgeted resources to decrease imaging/microfilm backlog with a five-year goal of being current with all of the county departments' imaging/microfilming projects.
 - Achieve and maintain a 95% on-time delivery of printed goods while providing good communication with affected department personnel when delivery will be delayed.
 - Analyze county departments' daily and standard mailings and make recommendations on ways to achieve potential cost savings to help control skyrocketing postage costs.

Expenditure Trends

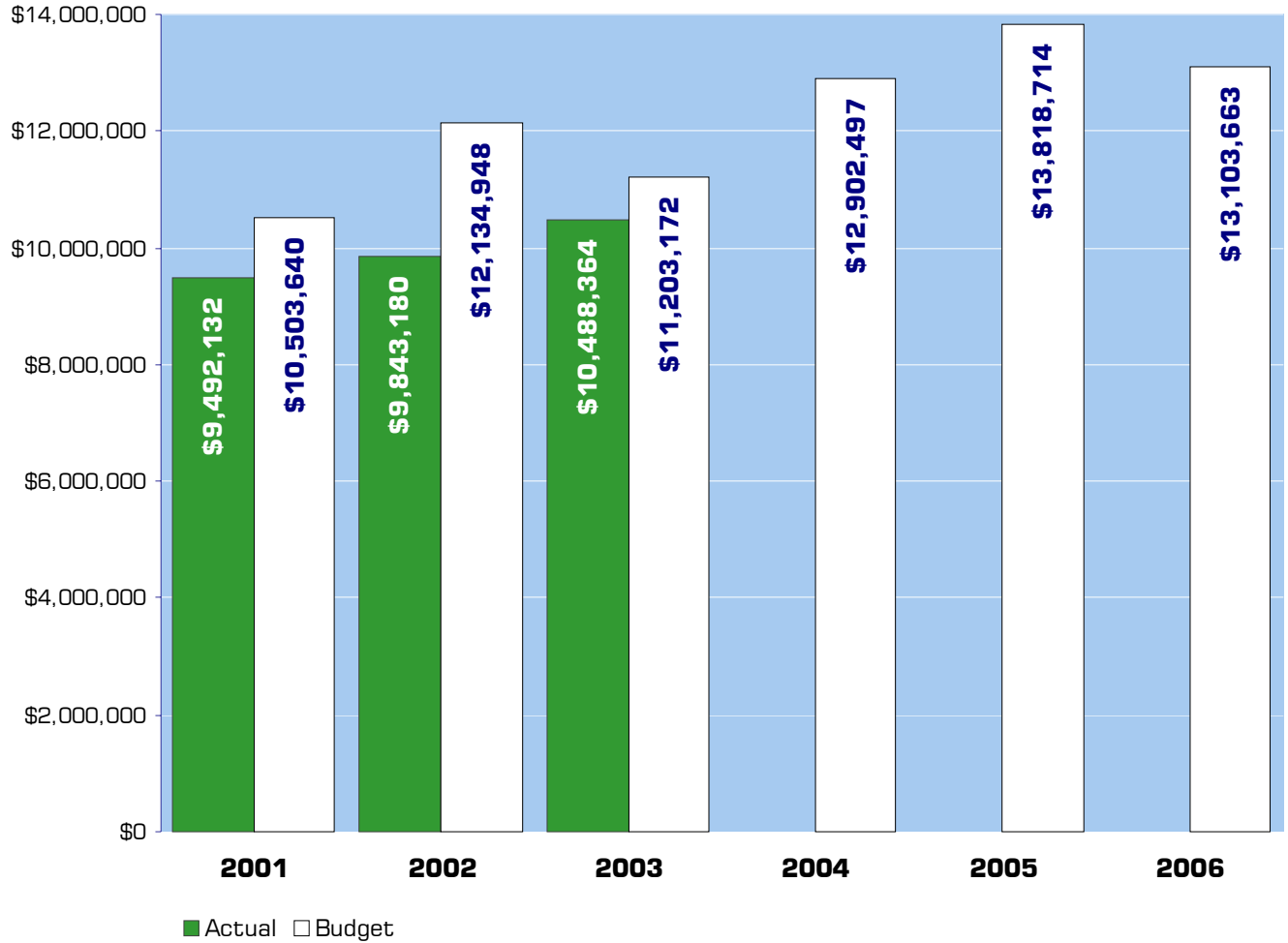

NOTE: Capital expenditures and interfund operating transfers are not shown to more accurately reflect ongoing operational costs.

2005-2006 Budget by Program

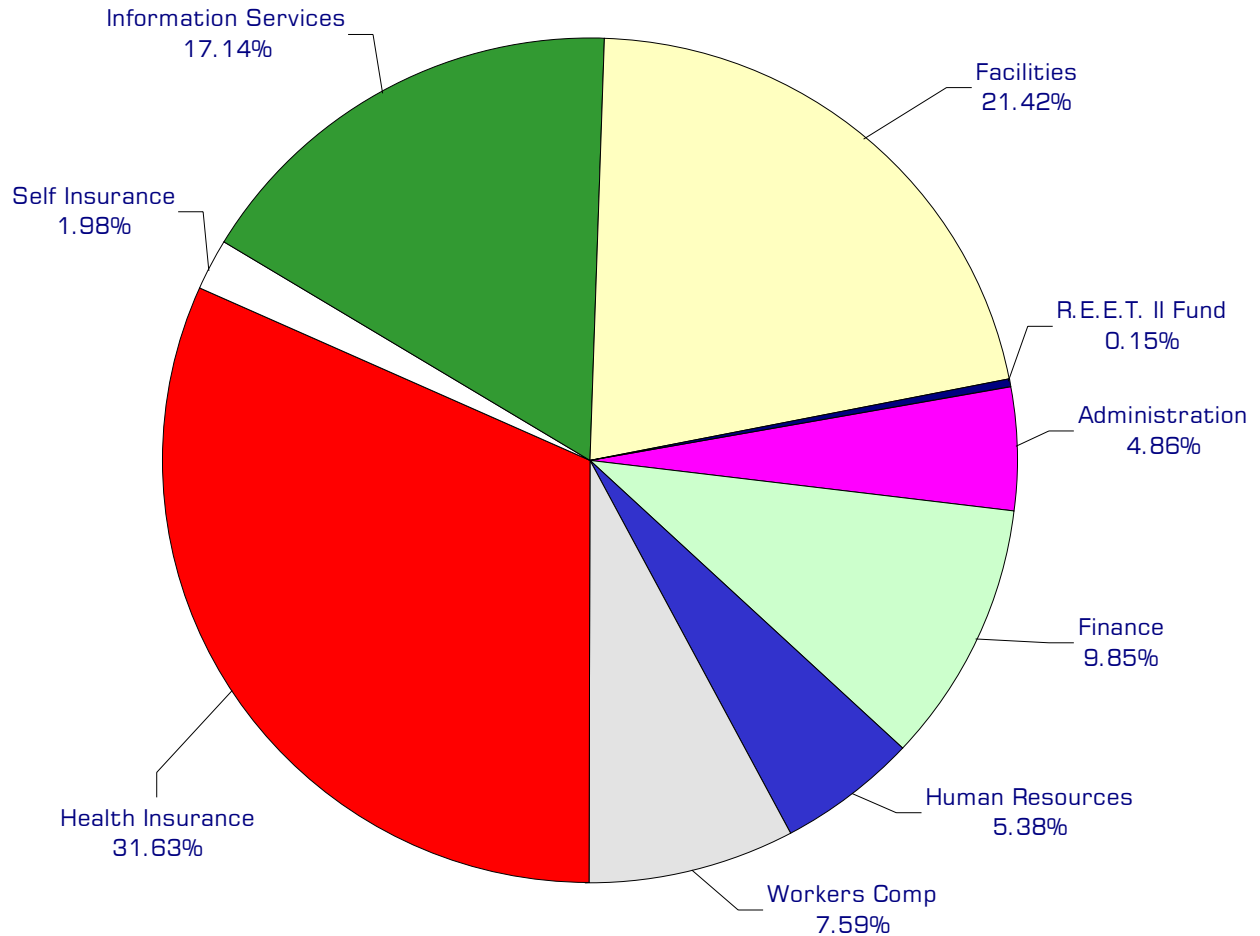

NOTE: Capital expenditures and interfund operating and residual equity transfers are not shown to more accurately reflect ongoing operational costs.

Program Summary

	Actual 2001	Actual 2002	Actual 2003	Budget 2004	Budget 2005	Budget 2006
OPERATIONS						
Administrative Services Fund						
Administration	93,877	71,741	115,850	658,625	981,606	326,613
Finance	809,712	871,733	964,722	1,236,737	1,312,394	1,338,841
Human Resources	629,410	574,235	582,273	674,001	715,148	734,450
Workers Comp	953,635	907,833	1,194,278	805,653	998,562	1,044,976
Health Insurance	2,694,102	2,155,930	2,654,348	3,821,394	4,044,380	4,470,610
Self Insurance	107,150	105,800	159,605	251,118	265,454	267,547
Information Services	1,938,014	1,925,360	1,868,425	2,157,549	2,268,679	2,347,145
Property Appraisal	-	424	-	7,010	7,010	7,010
Facilities	2,125,386	3,040,367	2,884,649	3,121,839	3,185,481	2,566,471
TR&R	140,846	135,671	59,393	-	-	-
BR&R	-	54,086	4,821	-	-	-
R.E.E.T. II Fund	-	-	-	164,354	40,000	-
Civic Center Bldg Impr Fund	-	-	-	4,217	-	-
<i>Total Admin Svcs Operations</i>	9,492,132	9,843,180	10,488,364	12,902,497	13,818,714	13,103,663
CAPITAL						
Administrative Services Fund						
Administration	-	-	3,595	90,300	119,300	1,800
Finance	50,710	-	-	3,000	-	-
Human Resources	1,163	-	1,164	2,400	2,400	2,400
Information Services	152,313	142,890	39,975	83,904	287,500	67,000
Facilities	22,320	30,332	338,153	64,341	458,590	-
TR&R	173,614	161,717	121,956	400,000	400,000	400,000
R.E.E.T. I Fund	-	-	-	889,000	100,000	100,000
Civic Center Bldg Impr Fund	-	-	34,432	-	-	-
<i>Total Admin Svcs Capital</i>	400,120	334,939	539,275	1,532,945	1,367,790	571,200
TRANSFERS						
Administrative Services Fund						
Administration	761	-	-	-	-	-
Finance	6,293	-	-	-	-	-
Human Resources	4,291	-	-	-	-	-
Information Services	11,052	-	-	-	-	-
Facilities	266,173	253,160	254,073	254,598	284,535	284,145
R.E.E.T. I Fund	665,847	689,428	993,173	1,192,565	1,178,015	1,186,128
Civic Center Bldg Impr Fund	-	-	700,000	-	-	-
<i>Total Admin Svcs Transfers</i>	954,417	942,588	1,947,246	1,447,163	1,462,550	1,470,273
<i>TOTAL Administrative Svcs</i>	10,846,669	11,120,707	12,974,885	15,882,605	16,649,054	15,145,136

2005-2006 Funding Sources

	2005	2006
Admin. Service Allocation	3,157,525	3,345,013
Intergovernmental Revenues	721,127	0
Charges for Printing & Paper	232,716	232,716
Custodial Maint. Chg	2,288,148	2,288,151
Copier Rentals	223,000	223,000
Interfund Insurance	5,113,625	5,536,527
Insurance Recovery	70,278	70,278
Mail	206,000	206,000
Space & Parking Rentals	301,112	301,112
Op Transfers -General Fund	828,763	383,305
Op Transfers - Public Works	236,699	202,984
Real Estate Excise Tax II Fund	40,000	0
Miscellaneous Revenues	136,985	170,227
*Fund Balance	262,736	144,350
Total Funding	13,818,714	13,103,663

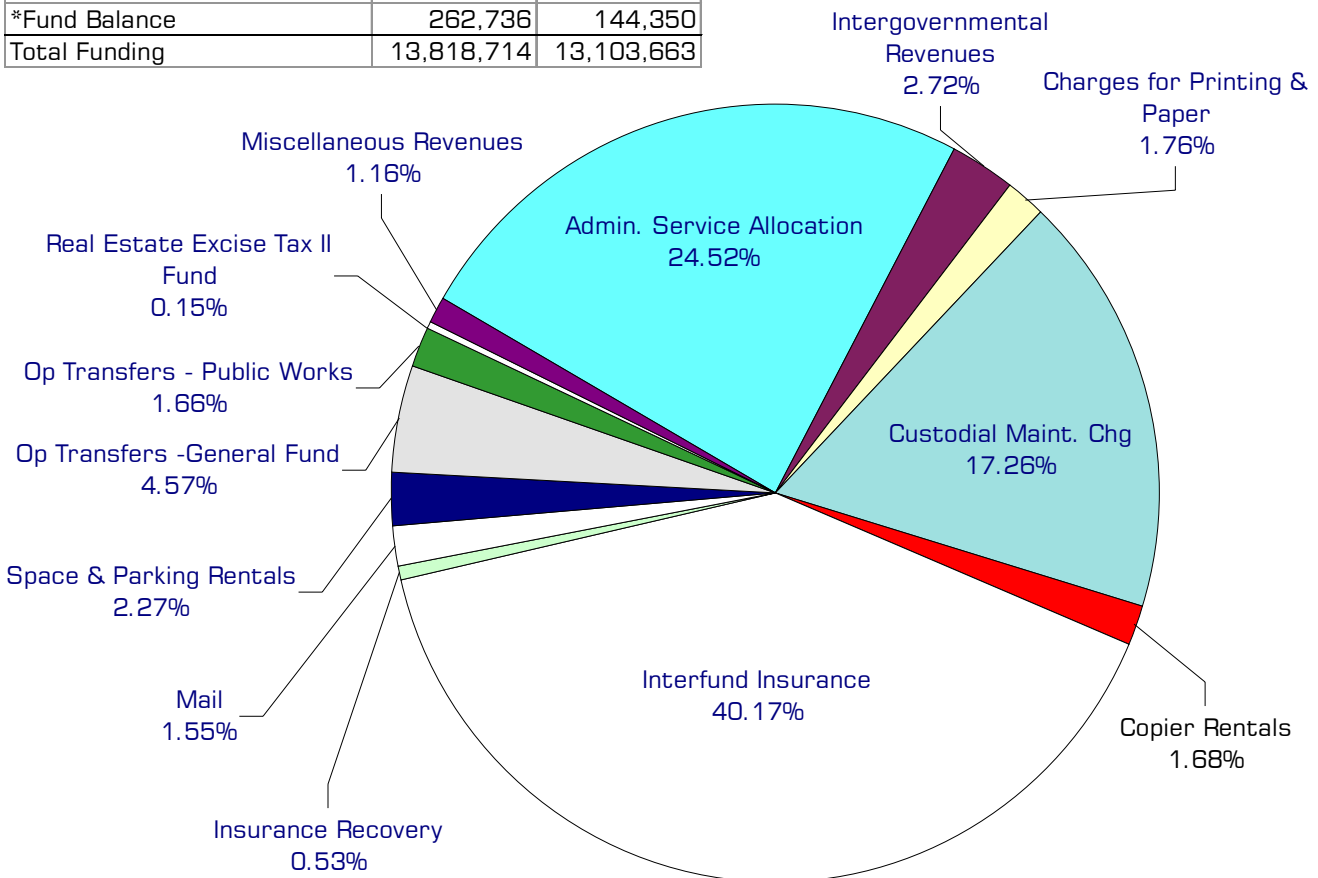

*Fund balance is not included in chart.

Funding Sources continued

Administrative Services Allocation

Interfund charge to distribute a portion of the cost of Administrative Services (AS) general services, such as Human Resources, Information Services, Administration and Accounting to independent funds. The charge is allocated based on such factors as budget size and number of employees.

Intergovernmental Revenue

A federal grant received by Administrative Services to fund a project coordinator and a programmer to implement a law and justice data integration project.

Charges for Printing & Paper

Revenue generated from the sale of printing services and paper to county departments.

Custodial Maintenance Charge

A charge per square foot to fund utilities, custodial services and maintenance of county facilities maintained by AS - Facilities.

Copier Rentals

Rental charged for the operation, maintenance and replacement of electrostatic copiers owned or leased by Administrative Services Department.

Interfund Insurance

Interfund assessments to provide for the cost of general liability insurance, health insurance, unemployment insurance and workers compensation insurance.

Insurance Recovery

Anticipated stop-loss recovery from secondary insurers.

Mail

Interfund charges for postage.

Space and Parking Rentals

Revenue received for office space rental in the Civic Center Building and parking fees in the county parking lots.

Operating Transfers - General Fund

Transfers to fund one-time repairs and maintenance costs such as HVAC, carpet, roof replacements, and interior painting.

Operating Transfers - Public Works Funds

Operating transfers in from the Road Fund to pay for a geographic information analyst, a computer technician, and to fund the Technology Revolving Fund (TR&R).

Real Estate Excise Tax II Fund

Revenue from this fund will pay for the cost of roof replacement at Silver Lake Lodge.

Miscellaneous Revenues

Includes amounts withheld from employees to fund their portion of health insurance premiums. Also includes charges to title companies for access to real property information on the county computer system.

Fund Balance

Fund balance will decrease by the amounts shown in the 2005-2006 funding source table on facing page. The graph (on facing page) does not include capital, operating transfers or Tort Fund.

Performance / Activity Measures

	Actual 2001	Actual 2002	Actual 2003	Projected 2004	Projected 2005	Projected 2006
<i>Facilities Management</i>						
Avg square footage serviced per custodian	22,500	22,500	22,500	24,000	24,000	24,000
Jail service requests	1,400	1,860	2,100	2,300	2,500	2,700
Juvenile Detention service requests	270	350	410	450	500	550
All other service requests	2,000	2,888	2,934	3,200	3,400	3,600
Preventive Maintenance Actions	400	1,000	1,100	1,400	1,500	1,600
<i>Finance</i>						
County accounts payable vouchers	36,010	36,272	34,360	35,506	36,000	36,200
District accounts payable vouchers	32,658	38,651	37,015	37,413	37,700	38,000
County payroll checks and direct deposits	27,702	28,008	28,466	28,800	29,200	29,600
District payroll checks and direct deposits	4,804	4,995	5,160	5,353	5,530	5,710
Purchase Orders issued	3,923	3,577	3,465	3,500	3,000	2,500
<i>Human Resources</i>						
Total Jobs Filled	159	127	105	110	110	110
Promotions & Transfers (jobs filled internally)	46%	42%	40%	50%	45%	45%
Time to Fill Jobs Internally (avg weeks)	6.2	3.7	3.5	3.5	3.5	3.5
Time to Fill Jobs Externally (avg weeks)	11.3	11.6	7.4	9	9	9
Turnover (separations divided by authorized positions)	7.2%	8.8%	6.4%	8%	8%	8%
Job Descriptions Updated	120	92	84	100	100	100
Training Hours - Management & Customer Service	1,692	573	520	800	750	750
Training Hours - Safety & Risk Management	1,092	816	2,243	1,800	1,000	1,000
Average Cost of Workers' Compensation Claims (\$)	8,271	2,218	4,414	4,000	4,400	5,000

continued on next page

Performance / Activity Measures continued

	Actual 2001	Actual 2002	Actual 2003	Projected 2004	Projected 2005	Projected 2006
<i>Information Services</i>						
Programming requests completed	637	517	525	575	600	650
AS/400 service calls	1,672	2,573	2,140	2,500	2,200	2,000
Phone service calls	228	68	213	250	200	175
PC/LAN service calls	20,122	16,400	24,615	20,000	26,000	26,000
Servers supported	31	35	38	40	40	43
PCs supported	800	827	831	850	850	850
Employees trained in-house	295	270	225	300	250	300
Average annual web page visitors	1,721,772	2,364,671	2,000,000	2,750,000	3,500,000	4,000,000
Pounds of records destroyed in accordance with retention schedules	35,310	52,915	35,347	35,000	37,000	37,000
Files/boxes retrieved from the Records Center for County departments.	1,193	1,135	1,043	1,100	1,150	1,200
Total cubic feet of records transferred/stored at Records Center	5,367	5,616	5,896	6,000	6,200	6,400
Rolls of microfilm produced: Other (case files & misc. projects)	353	236	273	125	50	20
Pages Scanned: Other (case files & misc. projects)	-	-	-	300,000	600,000	600,000
Rolls of microfilm produced: Clerk's Daily	25	27	29	14	-	-
Pages Scanned: Clerks Daily	-	-	-	34,800	34,800	-
Print orders completed on time	90%	91.5%	94.9%	95%	95%	95%
Amount saved through daily presort mail/bulk mail processes	\$ 5,245	\$ 2,127	\$ 2,523	\$ 2,500	\$ 2,500	\$ 2,500

Expenditures Summary

	Actual 2001	Actual 2002	Actual 2003	Budget 2004	Budget 2005	Budget 2006
ADMINISTRATIVE SERVICES FUND						
507100-507103 AS - Administration						
Salaries & Wages	60,753	54,639	74,361	210,140	244,165	151,390
Benefits	14,967	10,626	19,896	55,756	71,711	48,417
Supplies	2,182	642	1,372	24,500	39,942	13,442
Other Services & Charges	15,975	5,834	20,221	368,229	625,788	113,364
Capital Outlay	-	-	3,595	90,300	119,300	1,800
Operating Transfers	761	-	-	-	-	-
Total Administration	94,638	71,741	119,445	748,925	1,100,906	328,413
<i>Percent Change from Previous Year</i>	15.1%	-24.2%	66.5%	527.0%	47.0%	-70.2%
507130 & 507420 AS - Finance						
Salaries & Wages	490,619	505,206	575,276	656,862	673,193	683,330
Benefits	128,712	129,737	146,039	182,619	209,563	233,813
Supplies	21,637	23,548	22,804	32,688	43,628	35,688
Other Services & Charges	156,669	201,609	206,309	364,568	386,010	386,010
Capital Outlay	50,710	-	-	3,000	-	-
Debt Service	12,075	11,633	14,294	-	-	-
Operating Transfers	6,293	-	-	-	-	-
Total Finance	866,715	871,733	964,722	1,239,737	1,312,394	1,338,841
<i>Percent Change from Previous Year</i>	13.4%	0.6%	10.7%	28.5%	5.9%	2.0%
507140 AS - Human Resources						
Salaries & Wages	341,289	334,440	350,531	374,175	382,431	387,770
Benefits	81,507	90,583	78,714	100,504	123,781	137,744
Supplies	15,337	12,929	13,090	17,733	20,545	20,545
Other Services & Charges	191,277	136,283	139,938	181,589	188,391	188,391
Capital Outlay	1,163	-	1,164	2,400	2,400	2,400
Operating Transfers	4,291	-	-	-	-	-
Total Human Resources	634,864	574,235	583,437	676,401	717,548	736,850
<i>Percent Change from Previous Year</i>	13.1%	-9.5%	1.6%	15.9%	6.1%	2.7%
507300 AS - Workers Compensation						
Other Services & Charges	953,635	907,833	1,194,278	805,653	998,562	1,044,976
Total H/R Workers Comp.	953,635	907,833	1,194,278	805,653	998,562	1,044,976
<i>Percent Change from Previous Year</i>	107.1%	-4.8%	31.6%	-32.5%	23.9%	4.6%
507340, 507360 AS - Health Insurance						
Other Services & Charges	2,694,102	2,155,930	2,654,348	3,821,394	4,044,380	4,470,610
Total H/R Health Insurance	2,694,102	2,155,930	2,654,348	3,821,394	4,044,380	4,470,610
<i>Percent Change from Previous Year</i>	40.0%	-20.0%	23.1%	44.0%	5.8%	10.5%
507310, 507320, 507330 AS - Self Insurance Other						
Salaries & Wages	-	-	-	-	3,000	3,000
Other Services & Charges	107,150	105,800	159,605	251,118	262,454	264,547
Total AS Self Ins. Other	107,150	105,800	159,605	251,118	265,454	267,547
<i>Percent Change from Previous Year</i>	0.0%	-1.3%	50.9%	57.3%	5.7%	0.8%

continued on next page

Expenditures Summary continued

	Actual 2001	Actual 2002	Actual 2003	Budget 2004	Budget 2005	Budget 2006
507110, 507120, 507400, 507410 AS - Information Services						
Salaries & Wages	818,082	851,561	915,779	1,042,253	1,096,779	1,119,957
Benefits	231,849	212,706	242,412	292,361	344,701	385,989
Supplies	472,028	446,792	435,228	461,087	446,343	446,343
Other Services & Charges	416,055	414,301	275,006	361,848	380,856	394,856
Capital Outlay	152,313	142,890	39,975	83,904	287,500	67,000
Operating Transfers	11,052	-	-	-	-	-
<i>Total Information Services</i>	<i>2,101,379</i>	<i>2,068,250</i>	<i>1,908,400</i>	<i>2,241,453</i>	<i>2,556,179</i>	<i>2,414,145</i>
<i>Percent Change from Previous Year</i>	<i>22.6%</i>	<i>-1.6%</i>	<i>-7.7%</i>	<i>17.5%</i>	<i>14.0%</i>	<i>-5.6%</i>
507600 AS - Property Appraisal						
Other Services & Charges	-	424	-	7,010	7,010	7,010
<i>Total AS - Property Appraisal</i>	<i>-</i>	<i>424</i>	<i>-</i>	<i>7,010</i>	<i>7,010</i>	<i>7,010</i>
<i>Percent Change from Previous Year</i>	<i>0.0%</i>	<i>0.0%</i>	<i>-100.0%</i>	<i>0.0%</i>	<i>0.0%</i>	<i>0.0%</i>
50700-50784 & 5070501-5070505 ADS - Facilities Management						
Salaries & Wages	582,962	595,436	656,816	708,706	736,519	751,013
Benefits	165,045	195,875	207,727	246,475	290,912	320,624
Supplies	199,508	250,839	218,433	194,250	207,500	197,500
Other Services & Charges	1,166,333	1,991,715	1,795,364	1,959,598	1,937,740	1,284,524
Intergov Service & Charges	11,538	6,502	6,309	12,810	12,810	12,810
Capital Outlay	22,320	30,332	338,153	64,341	458,590	-
Operating Transfers	266,173	253,160	254,073	254,598	284,535	284,145
<i>Total Facilities Management</i>	<i>2,413,879</i>	<i>3,323,859</i>	<i>3,476,875</i>	<i>3,440,778</i>	<i>3,928,606</i>	<i>2,850,616</i>
<i>Percent Change from Previous Year</i>	<i>2.9%</i>	<i>37.7%</i>	<i>4.6%</i>	<i>-1.0%</i>	<i>14.2%</i>	<i>-27.4%</i>
507700 TR&R						
Supplies	140,846	135,671	58,155	-	-	-
Other Services & Charges	-	-	1,238	-	-	-
Capital Outlay	173,614	161,717	121,956	400,000	400,000	400,000
<i>Total TR&R</i>	<i>314,460</i>	<i>297,388</i>	<i>181,349</i>	<i>400,000</i>	<i>400,000</i>	<i>400,000</i>
<i>Percent Change from Previous Year</i>	<i>55.1%</i>	<i>-5.4%</i>	<i>-39.0%</i>	<i>120.6%</i>	<i>0.0%</i>	<i>0.0%</i>
507800 BR&R						
Other Services & Charges	-	54,086	4,821	-	-	-
<i>Total BR&R</i>	<i>-</i>	<i>54,086</i>	<i>4,821</i>	<i>-</i>	<i>-</i>	<i>-</i>
<i>Percent Change from Previous Year</i>	<i>0.0%</i>	<i>0.0%</i>	<i>-91.1%</i>	<i>-100.0%</i>	<i>0.0%</i>	<i>0.0%</i>
<i>Total AS Fund</i>	<i>10,180,822</i>	<i>10,431,279</i>	<i>11,247,280</i>	<i>13,632,469</i>	<i>15,331,039</i>	<i>13,859,008</i>
<i>Percent Change from Previous Year</i>	<i>24.7%</i>	<i>2.5%</i>	<i>7.8%</i>	<i>21.2%</i>	<i>12.5%</i>	<i>-9.6%</i>

Expenditures Summary continued

	Actual 2001	Actual 2002	Actual 2003	Budget 2004	Budget 2005	Budget 2006
324 R.E.E.T. II						
Salaries & Wages	-	-	-	4,354	-	-
Other Services & Charges	-	-	-	160,000	40,000	-
<i>Total R.E.E.T. II</i>	-	-	-	164,354	40,000	-
<i>Percent Change from Previous Year</i>	0%	0.0%	0.0%	0.0%	-75.7%	-100.0%
326 R.E.E.T. I						
Capital Outlay	-	-	-	889,000	100,000	100,000
Operating Transfers	665,847	689,428	993,173	1,192,565	1,178,015	1,186,128
<i>Total R.E.E.T. I</i>	665,847	689,428	993,173	2,081,565	1,278,015	1,286,128
<i>Percent Change from Previous Year</i>	-0.6%	3.5%	44.1%	109.6%	-38.6%	0.6%
331 CIVIC CENTER BLDG IMPROVEMENT FUND						
Other Services & Charges	-	-	-	4,217	-	-
Capital Outlay	-	-	34,432	-	-	-
Residual Equity	-	-	700,000	-	-	-
<i>Total Civic Ctr Bldg Impr Fund</i>	-	-	734,432	4,217	-	-
<i>Percent Change from Previous Year</i>	0%	0.0%	0.0%	-99.4%	-100.0%	0.0%
<i>TOTAL ADMIN SVCS</i>	10,846,669	11,120,707	12,974,885	15,882,605	16,649,054	15,145,136
<i>Percent Change from Previous Year</i>	22.8%	2.5%	16.7%	22.4%	4.8%	-9.0%

Services

Administration

Administration Support Services

Provide support for the AS Director, in the administration of the department as well as his role of Deputy County Administrator, by providing coordination and communication between divisions and the Executive's Office.

Administrative Policies & Procedures

Oversight of development of Administrative Policies & Procedures by A.S.-Policies & Procedures Writing Group.

Grants Coordination

Coordinate County government grant efforts.

Identify Grant Funding

Identify potential funding sources and their funding cycles.

Standardization of Contracts

Monitor use of standardized contracts and provide training.

GIS Administration

Administration/Coordination of GIS Services for Whatcom County.

Facilities Management

Building Management

Provide property and asset management including maintenance, custodial, grounds, security, parking and other related services for approximately 400,000 square feet. Provide project administration for facilities improvements and additions.

Finance

Accounts Payable

Review, document, generate and distribute the organization's accounts payable warrants.

Accounts Receivable

Generate, review, and post accounts receivable invoices.

Asset Management

Track and account for all county capital and attractive assets from acquisition to final disposal. Monitor the organization for compliance with county polices and state laws.

Budget Development

Prepare, publish and distribute the county's biennial budget. Provide analytical support to Executive's Office.

Services continued

District Accounting/Disbursements

Issue warrants for payment of claims junior taxing districts.

District Accounting/Payroll

Issue paychecks for special purpose districts and perform related disbursement activities, tax reporting and recordkeeping.

General Ledger & Annual Financial Report

Maintain general ledger, internal accounting controls and prepare year-end financial statement.

Jail Accounting

Process jail billings to other agencies for jail usage, account reconciliations, and other accounting functions.

Payroll

Issue paychecks in compliance with union agreements, county policy and state law and perform related disbursement activities, tax reporting and recordkeeping.

Public Works Accounting

Provide accounting services for Public Works ER&R division.

Purchasing

Issue purchase orders, coordinate bids, RFP's and furniture orders. Monitor the organization's purchasing activities to ensure compliance with county policies and state law.

Quarterly Financial Reports

Compile and distribute a Whatcom County financial report four times a year.

Human Resources

Classification & Compensation

Administer compensation and classification system to recruit, motivate, evaluate, and retain employees with those skills and attributes which support the county's mission and strategic plan for services.

Employee & Labor Relations

Administer personnel policies; negotiate and administer eight collective bargaining agreements covering 81% of county employees; investigate complaints; resolve grievances; assure good employee relations.

Employment & Recruitment

Coordinate employment processes to ensure selection of best suited candidates with qualifications and experience to meet the county's needs and for compliance with applicable laws.

Human Resources Information

Optimize use of computer and other technology to make operations more efficient and cost effective and to make Human Resources information more readily accessible.

Services continued

Management Services

Provide consistent information and recommendations to management on labor, employment, performance, benefits, leaves and other personnel issues through individual and group consultation and training.

Strategic Planning & Budgeting

Assure that resources, systems and strategies for the management of Whatcom County's 800+ employees focus on priority organizational goals.

Risk Management

Foster a safe and healthy workplace by managing risks, and offering training and wellness activities.

Employee Services

Coordinate benefit programs (health & welfare, paid and unpaid leave, workers' compensation, unemployment, retirement), conduct new employee orientations, exit interviews, and promote employee training and development.

Information Services

Computer Support

AS/400, local and wide area networks and personal computer hardware/software support.

Internet and Internal Intranet Development Services

Plan, develop, coordinate and administer public internet website and internal employee intranet to provide county information in-line 24/7.

Telecommunication Support

Troubleshoot and repair telephone system problems, including voice mail. Coordinate services with local telephone companies.

Wide Area Network (WAN) Integration

Plan, develop, coordinate and administer the county's wide area network operations.

Information Kiosk

Provide information to individuals who call the county's main telephone number as well as assist walk-up customers.

Records Management

A centralized county records management program provides efficient records management services to comply with state and federal laws regarding storage, protection and disposal of all county records.

Scanning/Microfilming

Prepping, filming, film processing, editing, indexing and film duplicating of various county records for the purposes of meeting state storage and preservation requirements.

Paper Sales

Services continued

Paper is stocked in the Print Shop so departments have immediate access to copy and computer paper when it is needed.

Printing Services

Providing in-house printing services; designing and ordering county envelopes and business cards; and, coordinating print orders requiring vendor services.

Courier Service

Daily pickup and delivery of packages, mail and supplies from the courthouse mailbox area to State Street Health, Forest Street Annex, Northwest Annex, Central Shop, and Girard Street Health.

Mailing Services

Collect, weigh, meter, sort and bundle all outgoing county mail and send by most cost effective means, process all UPS and FedEx outgoing letters/packages and bill departments for usage.

County Assessor's Office

An elected official, the County Assessor determines property values (real and personal), calculates levy rates and certifies tax rolls to the Treasurer. The Assessor's Office maintains inventory, description, ownership, sales and mapping for all real property parcels in Whatcom County. This office also administers and provides information regarding tax exemptions, such as senior citizen/disabled persons, open space, forest land, et cetera.

FTE's for this department

Year	2001	2002	2003	*2004	*2005	*2006	<i>*budget</i>
FTE	30.00	30.00	30.00	30.00	30.00	30.00	

The chart below shows the organizational structure for 2005 only.

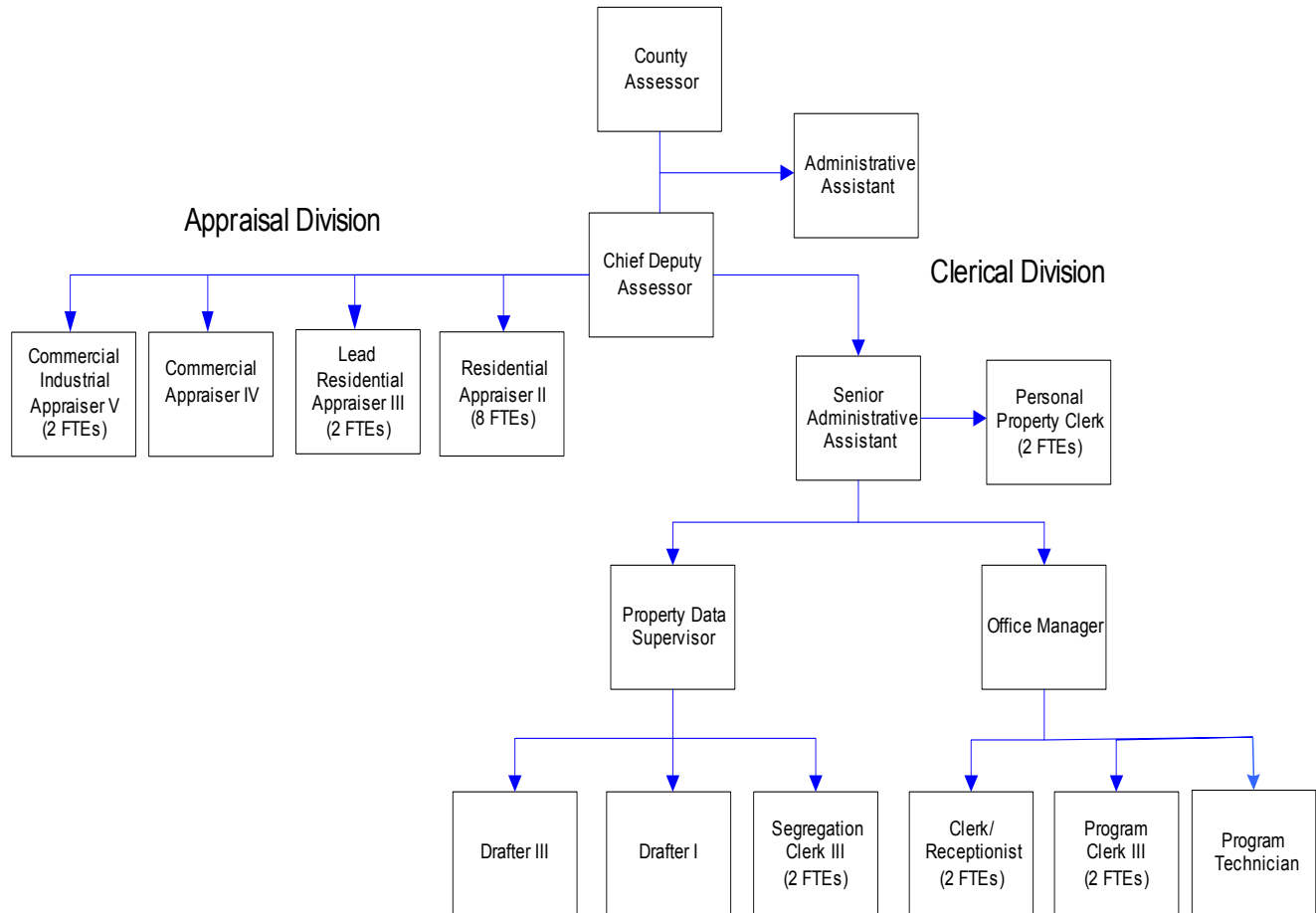

Mission & Objectives

Mission

Provide fair and equitable professional property tax administration. Operate under the rules, regulations, and supervision contained in the Constitution of the State of Washington, set by Washington State Law, and directed by the Washington State Department of Revenue. Deliver quality customer service with irrefutable performance. Accomplish goals and objectives with a taxpayer responsive analysis of cost, intelligent alternatives, customer priorities and practicality.

Objectives

- A complete revaluation of approximately one quarter (24,000) of the parcels of real property to establish the county-wide tax base for taxing districts.
- A revaluation of all personal property to establish the tax base.
- Discover, list and appraise all real and personal property new constructions to add valuations to the tax base.
- Maintain an accurate property ownership, parcel data base and cartographic mapping for all property.
- Allocation of valuation to taxing districts, calculation of levy taxes and certification of tax rolls for the County Treasurer.
- Provide information, education and assistance to taxpayers and governmental agencies.
- Prepare defenses of valuations and actions before the Whatcom County Board of Equalization, Washington State Board of Tax Appeals and the State Superior Court.

Expenditure Trends

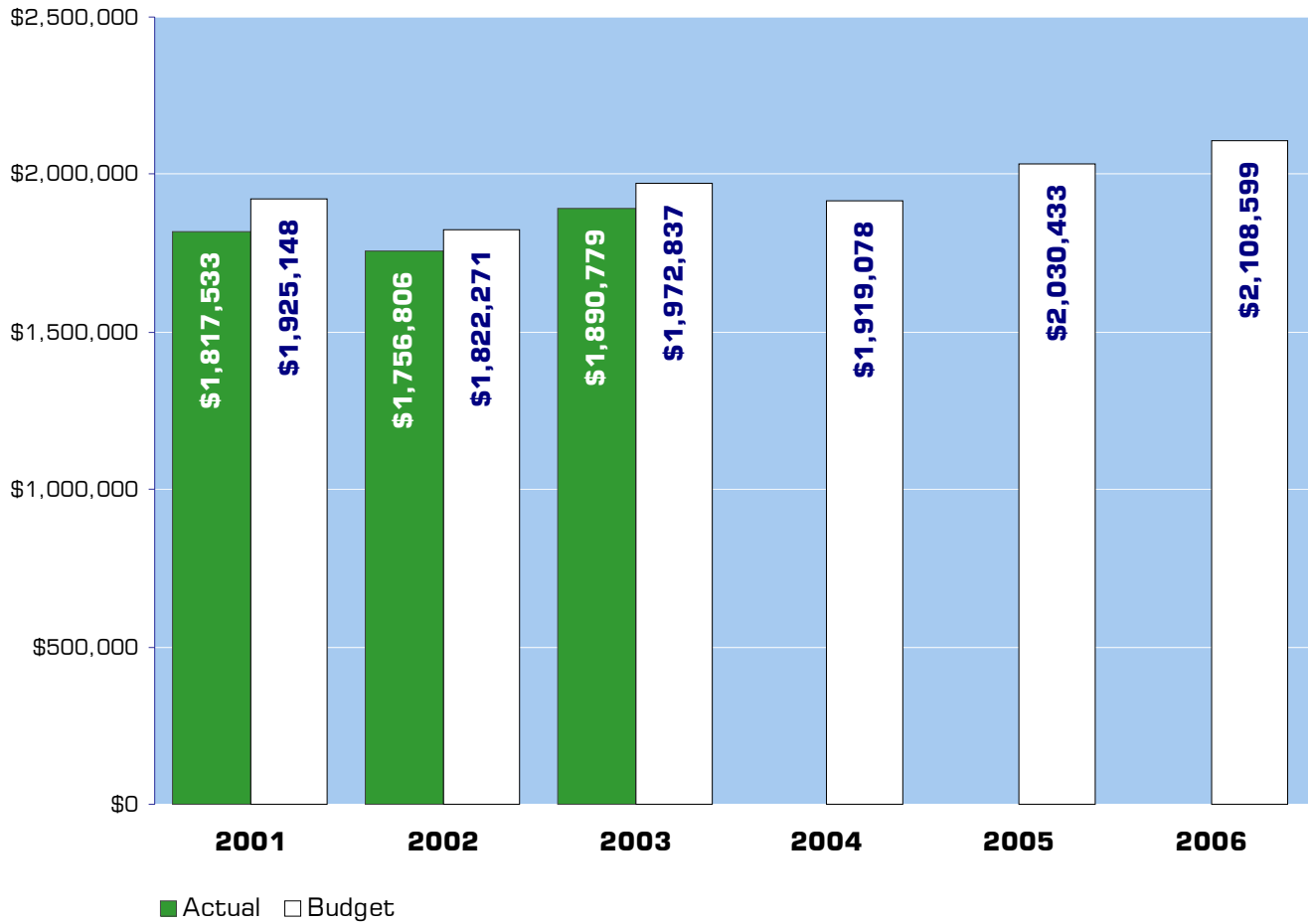

NOTE: Capital expenditures and interfund operating transfers are not shown to more accurately reflect ongoing operational costs.

2005-2006 Budget by Program

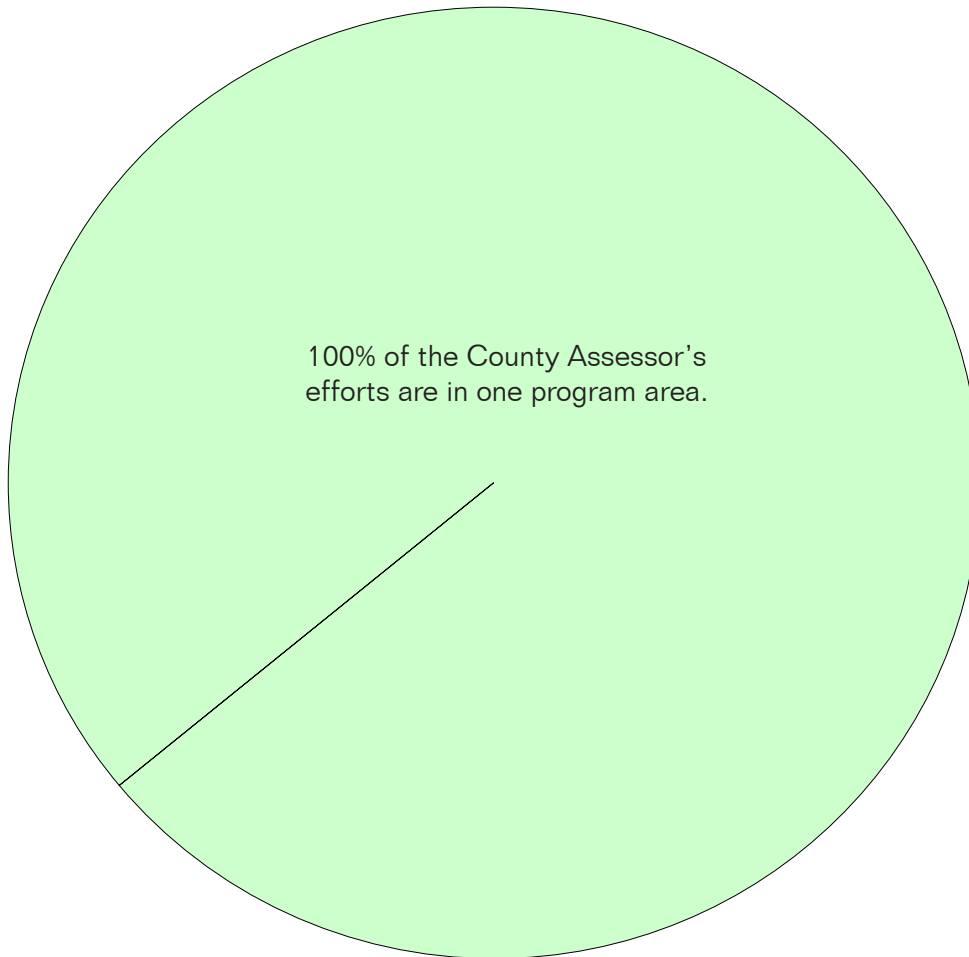

NOTE: Capital expenditures are not shown to more accurately reflect ongoing operational costs.

Program Summary

Actual 2001	Actual 2002	Actual 2003	Budget 2004	Budget 2005	Budget 2006
----------------	----------------	----------------	----------------	----------------	----------------

OPERATIONS

General Fund

300 Assessor	1,817,533	1,756,806	1,890,779	1,919,078	2,030,433	2,108,599
<i>Total Assessor Operations</i>	1,817,533	1,756,806	1,890,779	1,919,078	2,030,433	2,108,599

CAPITAL

General Fund

300 Assessor - Capital	20,638	3,428	-	-	23,995	-
<i>Total Assessor Capital</i>	20,638	3,428	-	-	23,995	-

TRANSFERS

General Fund

300 Assessor - Transfers	15,080	-	-	-	-	-
<i>Total Assessor Transfers</i>	15,080	-	-	-	-	-

TOTAL ASSESSOR	1,853,251	1,760,234	1,890,779	1,919,078	2,054,428	2,108,599
<i>Percent Change from Previous Year</i>	8.3%	-5.0%	7.4%	1.5%	7.1%	2.6%

2005-2006 Funding Sources

	2005	2006
Charges For Services	14,500	14,500
General Fund	2,015,933	2,094,099
Total Funding	2,030,433	2,108,599

Charges for Services

The Assessor collects revenues from its fire patrol fee and printing and duplication of documents and records.

General Fund

Undedicated General Fund resources.

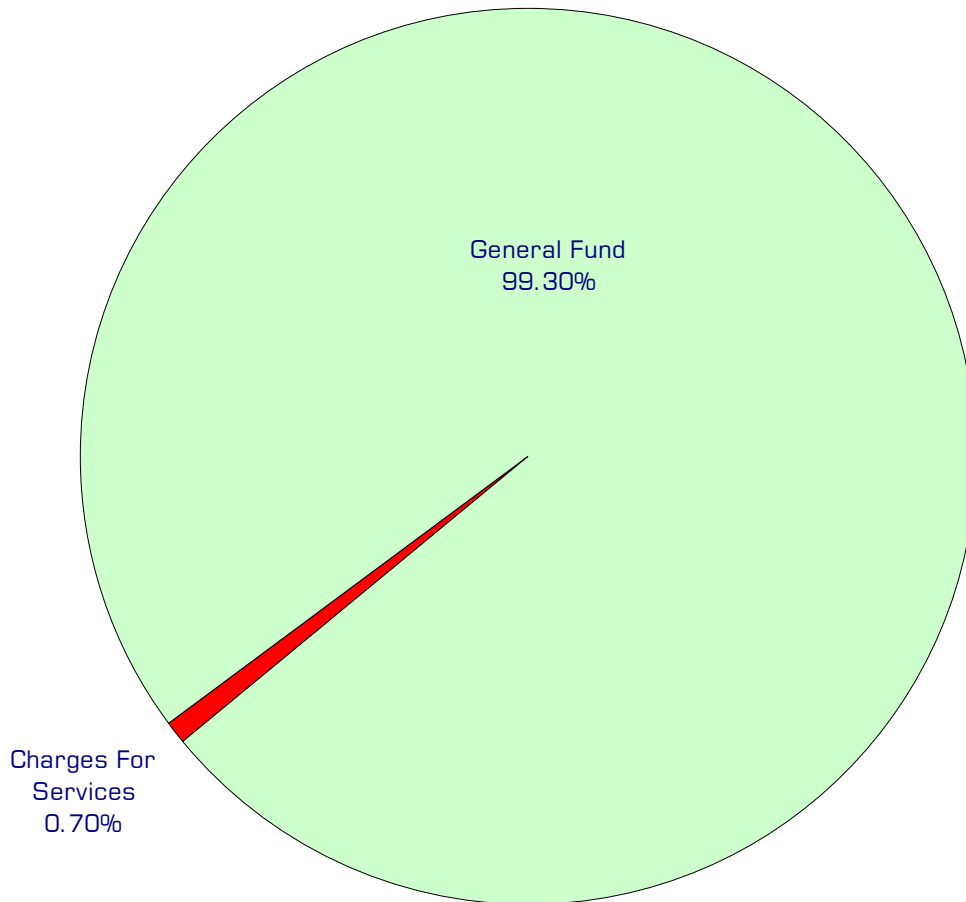

Performance / Activity Measures

	Actual 2001	Actual 2002	Actual 2003	Projected 2004	Projected 2005	Projected 2006
Property Tax Dollars to County	34,225,240	35,382,670	36,330,875	37,085,570	38,200,000	39,600,000
Flood Control Zone District Dollars	3,830,535	3,991,895	4,118,180	2,531,606	2,629,925	2,710,000
Real Property Parcels	100,483	101,362	102,025	102,261	102,600	103,250
Combination/Segregations Processed	5,561	5,700	5,165	3,872	3,500	3,500
New Construction tax dollars to county	868,686	707,880	912,335	895,680	1,500,000	1,000,000
New Construction Valuation (Total)	318,081,235	285,033,285	332,691,325	348,837,740	625,000,000	400,000,000
Building Permits Evaluated	4,139	3,987	4,434	5,276	5,600	5,250
New Single Family Res. added assessments	1,887	1,792	1,916	1,992	2,100	2,000
Board of Equalization Petitions	334	209	300	157	250	300
Total Property Tax Revenue	149,225,555	154,832,280	160,226,167	169,179,734	179,300,000	187,250,000

Expenditures Summary

	Actual 2001	Actual 2002	Actual 2003	Budget 2004	Budget 2005	Budget 2006
GENERAL FUND						
300 Assessor						
Salaries & Wages	1,126,189	1,106,842	1,221,223	1,280,887	1,315,487	1,337,341
Benefits	305,716	293,092	330,711	372,729	422,802	472,549
Supplies	38,146	32,511	32,348	37,080	32,660	32,660
Other Services & Charges	347,482	324,361	306,497	228,382	259,484	266,049
Capital Outlay	20,638	3,428	-	-	23,995	-
Operating Transfers	15,080	-	-	-	-	-
<i>TOTAL ASSESSOR</i>	1,853,251	1,760,234	1,890,779	1,919,078	2,054,428	2,108,599
<i>Percent Change from Previous Year</i>	8.3%	-5.0%	7.4%	1.5%	7.1%	2.6%

Services

Assessor - Public Assistance

Provide assistance to public inquiries by phone and at office counter. Also provide outreach program of public educational seminar presentations to interested groups on property tax related topics.

Assessor's Database Management

Maintains an accurate property ownership/taxpayer, parcel inventory data, taxing district boundary definitions, land use definition, assessed valuation data and mapping for all properties and accounts.

New Construction Valuation

Inspects and determines value of new construction.

Personal Property Valuation

Businesses must report their equipment and asset listings annually. These are valued at 100% assessed value to market value relationships.

Real Property Revaluation

Physically inspects and revalues real property parcels on a continuous systematic cycle, at least once every four years to re-establish a 100% assessed value to market value relationship.

Taxroll Processing

Process assessment roll to certification as a Property Tax receivable collection roll for the Treasurer's billing, collection and distribution. Reports and audit verification are required by statute, and accurate calculations and distributions must be provided.

Valuation Defense

Answers to valuation and procedures before a distinct and separate administrative appeals mechanism.



County Auditor's Office

An elected official, the County Auditor provides voter registration, conducts elections, records land documents, issues marriage licenses, motor vehicle and vessel licenses. This office also performs an internal audit function for the organization.

FTE's for this department

Year	2001	2002	2003	*2004	*2005	*2006
FTE	18.00	18.00	19.00	20.00	22.00	22.00

**budget*

The chart below shows the organizational structure for 2005 only.

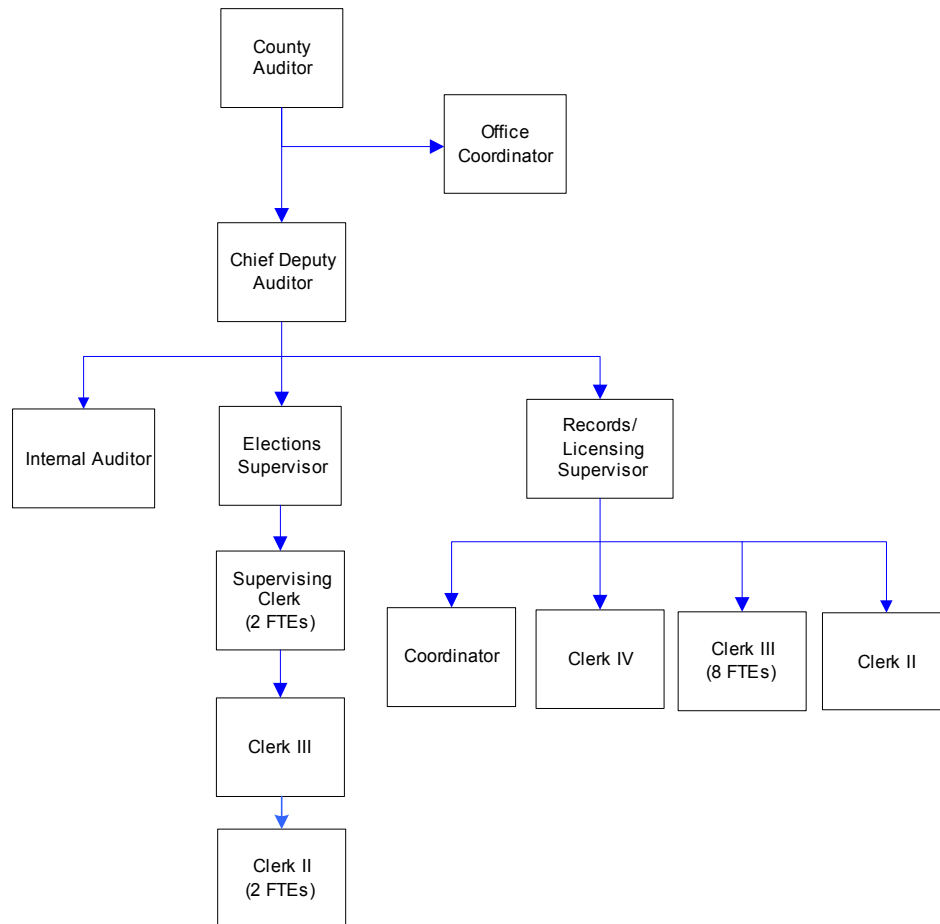

Mission & Objectives

Mission

The Whatcom County Auditor's Office is committed to excellence in public service, easy access to information and efficient operations in the delivery of services to the citizens of this county. It is the mission of the Auditor's office to efficiently manage the electoral process, records management and preservation, vehicle, vessel and marriage licensing services, and internal audit to ensure those responsibilities are performed in a professional, forthright and fair manner. This includes a commitment to continuous improvement with each division of the office supporting and complementing each other in a work environment that fosters and encourages innovation, cooperation and growth.

Objectives

Elections

- Complete implementation of election management system to enable coordination of poll workers with financial system; integrate with Geographical Information System (GIS) to map precincts and districts; integrate with the statewide voter registration database.
- Identify equipment needs and select vendor for purchase of new voting equipment system to be installed by June, 2005.
- Set performance standard for accuracy level and quantity in entering election management system information.

Internal Audit

- Reduce the number of outstanding follow-up audits to two, and convert to an annual follow up format, focusing on management's established action deadlines for each individual audit.
- Perform two new, non-follow up, operational audits each year.
- Improve compliance with auditing standards through further development of the Internal Audit policies and a quality control review.
- Develop and implement one new continuous auditing system, using ACL.
- Improve Internal Audit management by utilizing a published entity-wide risk assessment.
- Publish four issues of the WCIA Today quarterly Internal Audit newsletter each year.
- Publish four Internal Audit questionnaires and response summaries each year.

Objectives continued

- Publish four Internal Audit topical white-papers each year, regarding topics such as risk management or various internal controls.

Public Services

- Establish Recording production standards: Record documents presented within 24 hours of submission; Scan documents recorded within 24 hours; Complete indexing, verification of documents and return originals within 7 days.
- Develop performance standards for measuring number of documents recorded and number of documents indexed.
- Set acceptable standard for Licensing clerks to achieve daily cash/check allocation accuracies.
- Process licensing mail within 2 days of receipt.
- Develop incentives for accomplishment of performance standards.

Expenditure Trends

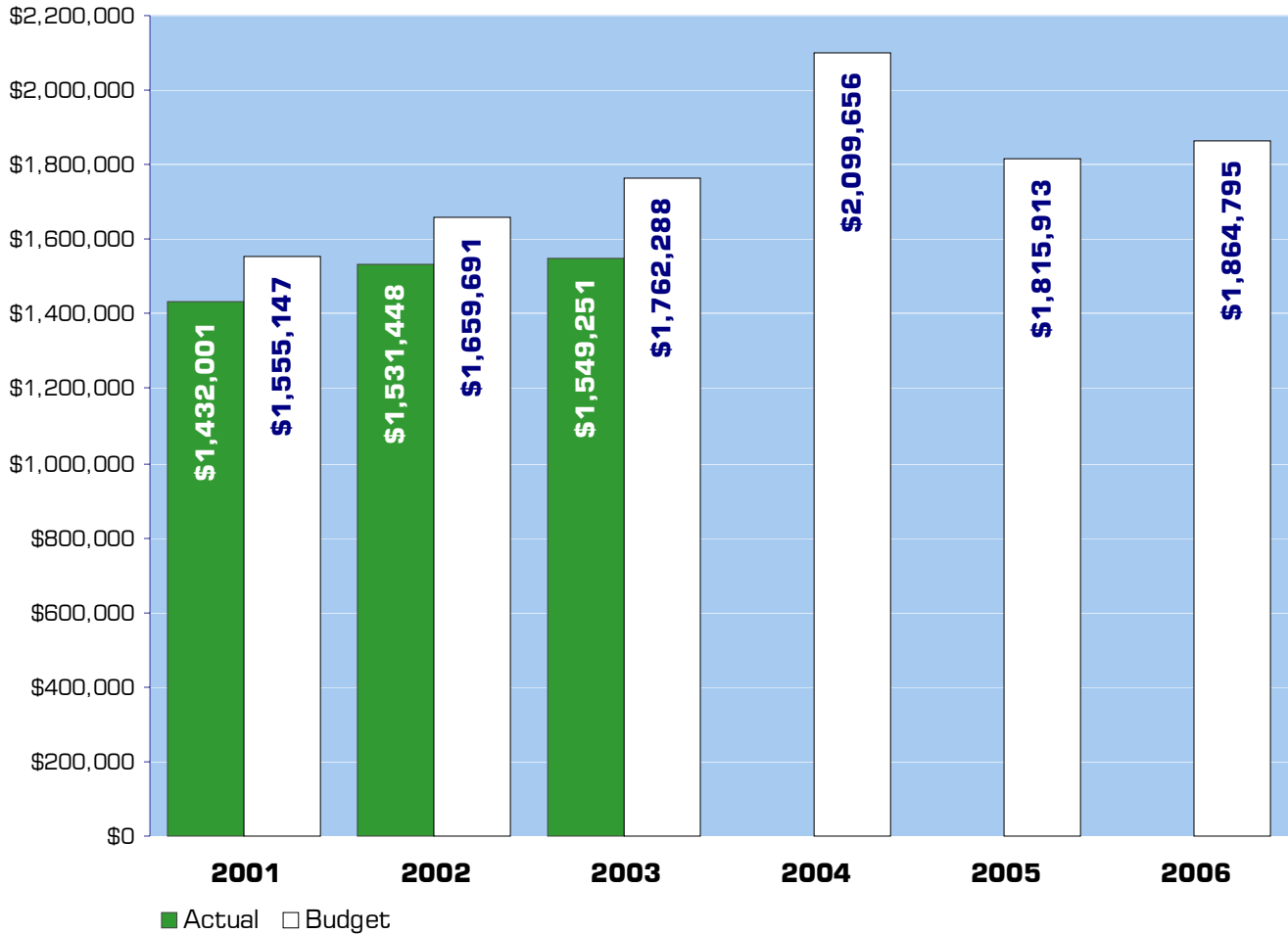

NOTE: Capital expenditures and interfund operating transfers are not shown to more accurately reflect ongoing operational costs.

2005-2006 Budget by Program

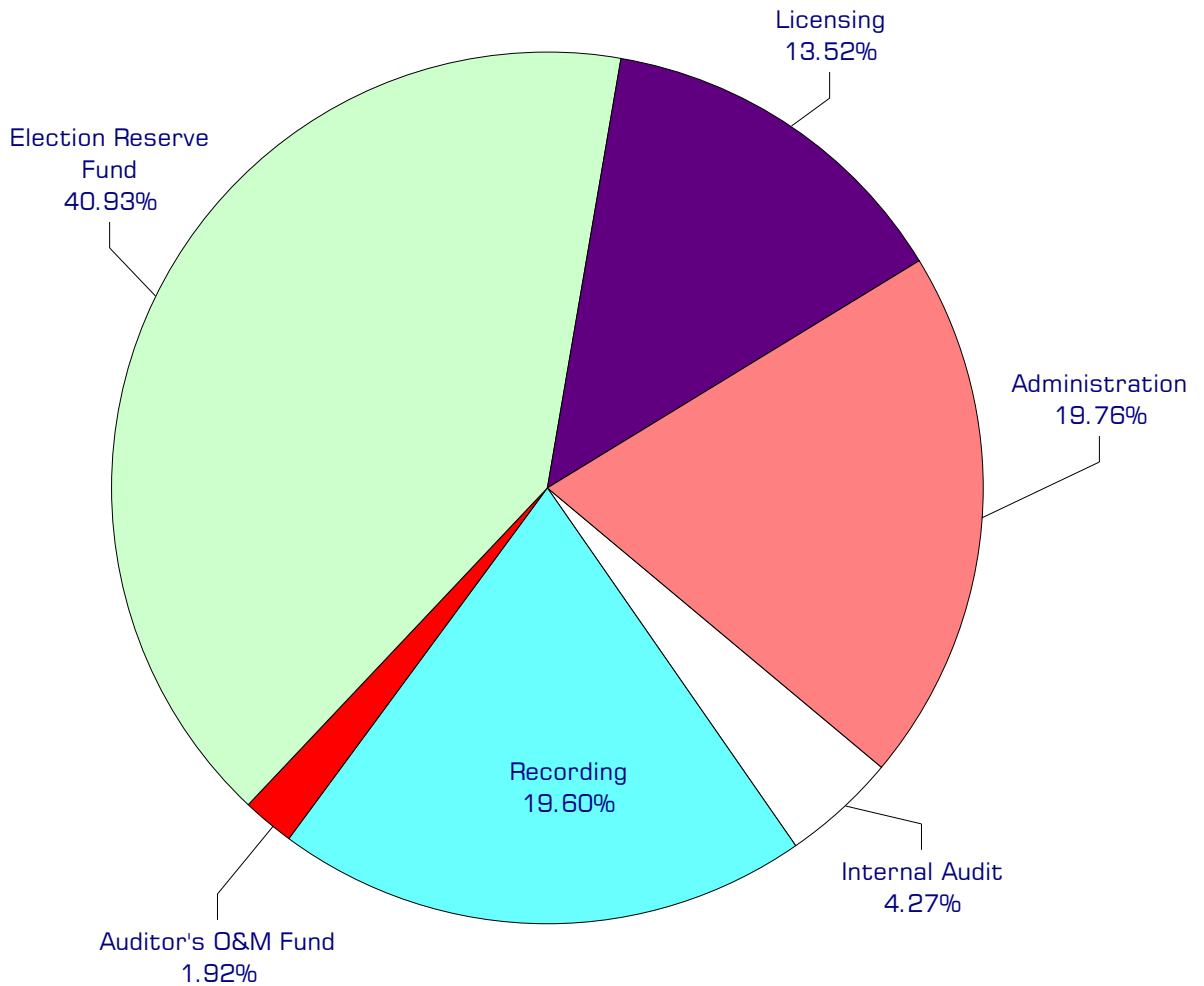

NOTE: Capital expenditures and interfund operating and residual equity transfers are not shown to more accurately reflect ongoing operational costs.

Program Summary

	Actual 2001	Actual 2002	Actual 2003	Budget 2004	Budget 2005	Budget 2006
OPERATIONS						
General Fund						
510 Internal Audit	84,381	64,100	87,898	76,009	76,955	80,080
520 Administration	177,883	200,388	212,183	221,325	356,801	370,553
540 Recording	307,404	310,595	369,594	388,399	351,332	369,952
560 Licensing	251,934	251,010	268,470	271,505	244,954	252,634
Election Reserve Fund	595,337	691,565	601,249	868,718	745,654	760,959
Auditor's O&M Fund	15,061	13,790	9,857	273,700	40,217	30,617
Total Auditor Operations	1,432,000	1,531,448	1,549,251	2,099,656	1,815,913	1,864,795
<i>Percent Change from Previous Year</i>	-7.0%	6.9%	1.2%	35.5%	-13.5%	2.7%
CAPITAL						
General Fund						
510 Internal Audit	-	-	-	-	-	-
560 Licensing	4,046	-	-	-	-	-
Election Reserve Fund Capital	-	-	5,953	708,500	-	-
Auditor's O&M Fund Capital	7,776	15,256	4,004	122,988	5,000	-
Total Auditor Capital	11,822	15,256	9,957	831,488	5,000	-
<i>Percent Change from Previous Year</i>	9.7%	29.0%	-34.7%	8250.8%	-99.4%	-100.0%
TRANSFERS						
General Fund						
510 Internal Audit	722	-	-	-	-	-
520 Administration	2,059	-	-	-	-	-
540 Recording	2,094	-	-	-	-	-
560 Licensing	1,731	-	-	-	-	-
Auditor's O&M Fund Transfers	-	-	19,171	37,864	74,712	79,393
Election Reserve Fund Transfers	2,808	-	-	-	-	-
Total Auditor Transfers	9,414	-	19,171	37,864	74,712	79,393
<i>Percent Change from Previous Year</i>	0.0%	-100.0%	0.0%	97.5%	97.3%	6.3%
TOTAL AUDITOR	1,453,236	1,546,704	1,578,379	2,969,008	1,895,625	1,944,188
<i>Percent Change from Previous Year</i>	-6.3%	6.4%	2.0%	88.1%	-36.2%	2.6%

2005-2006 Funding Sources

	2005	2006
Filing/Recording Fees	600,000	600,000
Motor Vehicle License Fees	890,000	890,000
Prop Tax - Election Reserve	360,000	360,000
Miscellaneous Revenue	95,300	97,300
Auditor's O&M	125,400	125,400
Election Charges	280,749	283,749
General Fund	(541,258)	(500,081)
*Fund Balance	5,722	8,427
Total Funding	1,815,913	1,864,795

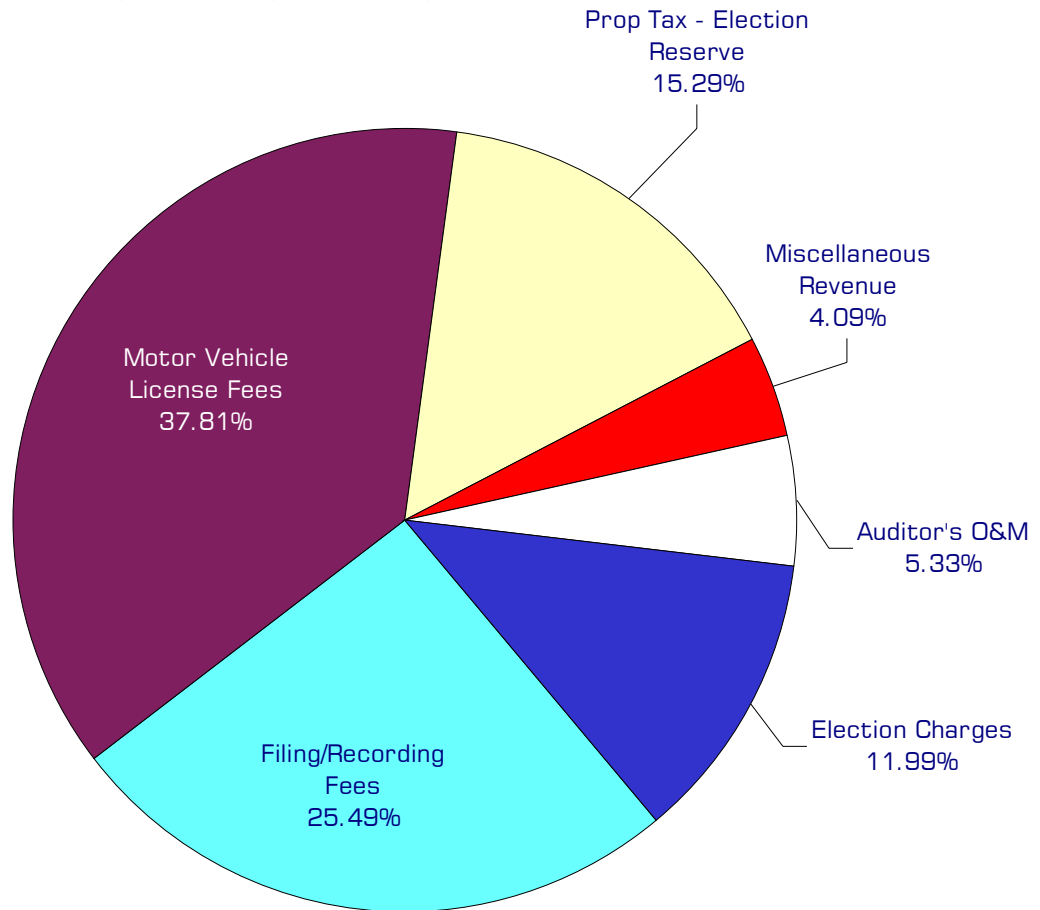

*Fund Balance and General Fund categories are not included in chart.

Funding Sources continued

Filing/Recording

Fees collected on filing and recording of transactions, such as real property sales.

Motor Vehicle License

Fees received for vehicle license renewals and title transfers performed in Whatcom County by county and subagent staff.

Property Tax - Election Reserve

Property tax levy to fund the cost of voter registration and administration of regular and special state and county elections.

Miscellaneous Revenue

Small amounts of revenue collected from a variety of sources such as marriage license fees and certified copies.

Auditor's Operations & Maintenance (O & M)

Fees collected in Whatcom County to fund document recording. The state receives fees on every recorded document. A portion of this fee is reallocated to the county. Additionally, the county collects a fee on each document recorded. The revenue from these fees is used to acquire and maintain document recording systems.

Election Charges

The county is reimbursed by local jurisdictions for the cost of administering all elections in those jurisdictions and additionally, is reimbursed for costs of maintaining voter registration by cities. State reimbursement for elections occurs only in odd numbered years. The department also receives revenue from the sale of election publications, printing/duplicating and candidate filing fees.

General Fund

Auditor revenues contribute to undedicated General Fund resources.

Fund Balance

Current year operations will result in an increase to the Auditor's O & M fund and a decrease to the Election Reserve fund balances, with an overall net fund balance decrease.

Performance / Activity Measures

	Actual 2001	Actual 2002	Actual 2003	Projected 2004	Projected 2005	Projected 2006
<i>General Tracking</i>						
Registered Voters-Active	103,000	91,656	95,000	105,000	108,000	105,000
Registered Voters-Inactive	15,000	18,000	13,000	8,000	8,000	10,000
License Transactions	227,362	237,264	242,000	247,000	252,000	255,000
Document Recordings	54,429	66,339	86,556	72,000	75,000	77,000
Marriage Licenses	1,330	1,262	1,354	1,380	1,400	1,450
<i>Internal Audit</i>						
Publish four issues of quarterly newsletter					4	4
Publish four IA questionnaires					4	4
Perform two follow-up audits					2	2
Perform two new, non-followup audits					2	2
Publish four whitepapers					4	4
Undergo a quality control review						1
Publish an entity-wide risk assessment						1
<i>Public Services</i>						
Record documents within 24 hours (days target complete)					240	240
Scan documents within 24 hours (days target complete)					220	240
Index, verify & return documents in 7 days (days target complete)					200	220
Licensing mail processed within 2 days (days target complete)					240	250
Clerk balancing cash/check allocation at acceptable level (months target complete)					12	12

Expenditures Summary

	Actual 2001	Actual 2002	Actual 2003	Budget 2004	Budget 2005	Budget 2006
GENERAL FUND						
510 Internal Audit						
Salaries & Wages	59,442	31,888	44,731	47,494	49,381	51,538
Benefits	14,811	8,537	11,725	12,860	14,824	16,792
Supplies	1,013	1,769	1,767	2,500	2,500	2,600
Other Services & Charges	9,115	21,906	29,675	13,155	10,250	9,150
Operating Transfers	722	-	-	-	-	-
<i>Total Internal Audit</i>	<i>85,103</i>	<i>64,100</i>	<i>87,898</i>	<i>76,009</i>	<i>76,955</i>	<i>80,080</i>
<i>Percent Change From Previous Year</i>	<i>-27.5%</i>	<i>-24.7%</i>	<i>37.1%</i>	<i>-13.5%</i>	<i>1.2%</i>	<i>4.1%</i>
520 Administration						
Salaries & Wages	140,537	163,618	172,726	177,012	166,944	169,273
Benefits	35,348	36,770	39,457	44,313	48,499	54,242
Other Services & Charges	1,998	-	-	-	141,358	147,038
Operating Transfers	2,059	-	-	-	-	-
<i>Total Administration</i>	<i>179,942</i>	<i>200,388</i>	<i>212,183</i>	<i>221,325</i>	<i>356,801</i>	<i>370,553</i>
<i>Percent Change From Previous Year</i>	<i>57389.5%</i>	<i>11.4%</i>	<i>5.9%</i>	<i>4.3%</i>	<i>61.2%</i>	<i>3.9%</i>
540 Recording						
Salaries & Wages	149,670	121,488	187,547	196,642	208,867	217,267
Benefits	43,938	37,387	56,874	68,508	87,525	97,843
Supplies	5,890	38,139	8,583	7,000	7,840	7,842
Other Services & Charges	107,906	113,581	116,590	116,249	47,100	47,000
Operating Transfers	2,094	-	-	-	-	-
<i>Total Recording</i>	<i>309,498</i>	<i>310,595</i>	<i>369,594</i>	<i>388,399</i>	<i>351,332</i>	<i>369,952</i>
<i>Percent Change From Previous Year</i>	<i>14.7%</i>	<i>0.4%</i>	<i>19.0%</i>	<i>5.1%</i>	<i>-9.5%</i>	<i>5.3%</i>
560 Licensing						
Salaries & Wages	139,222	140,064	142,970	145,688	151,127	152,878
Benefits	37,752	35,809	41,206	46,403	52,927	58,856
Supplies	6,418	5,056	1,790	5,900	5,900	5,900
Other Services & Charges	68,542	70,081	82,504	73,514	35,000	35,000
Capital Outlay	4,046	-	-	-	-	-
Operating Transfers	1,731	-	-	-	-	-
<i>Total Licensing</i>	<i>257,711</i>	<i>251,010</i>	<i>268,470</i>	<i>271,505</i>	<i>244,954</i>	<i>252,634</i>
<i>Percent Change From Previous Year</i>	<i>-23.1%</i>	<i>-2.6%</i>	<i>7.0%</i>	<i>1.1%</i>	<i>-9.8%</i>	<i>3.1%</i>
<i>Total General Fund</i>	<i>832,254</i>	<i>826,093</i>	<i>938,145</i>	<i>957,238</i>	<i>1,030,042</i>	<i>1,073,219</i>
<i>Percent Change From Previous Year</i>	<i>15.2%</i>	<i>-0.7%</i>	<i>13.6%</i>	<i>2.0%</i>	<i>7.6%</i>	<i>4.2%</i>

continued on next page

Expenditures Summary continued

	Actual 2001	Actual 2002	Actual 2003	Budget 2004	Budget 2005	Budget 2006
ELECTION RESERVE FUND						
10904 Election Costs						
Salaries & Wages	237,365	261,469	220,536	338,199	257,454	262,531
Benefits	47,528	54,858	54,197	88,588	80,436	88,605
Supplies	75,520	65,460	73,746	144,791	90,331	87,973
Other Services & Charges	135,212	160,801	150,970	161,202	133,509	141,279
Capital Outlay	-	-	5,953	578,500	-	-
Operating Transfers	2,106	-	-	-	-	-
<i>Total Election Costs</i>	497,731	542,588	505,402	1,311,280	561,730	580,388
<i>Percent Change From Previous Year</i>	-26.1%	9.0%	-6.9%	159.5%	-57.2%	3.3%
10906 Registrations						
Salaries & Wages	51,043	70,394	55,251	72,400	66,187	67,243
Benefits	15,076	18,441	17,386	18,275	24,951	27,519
Supplies	2,352	1,527	1,184	9,300	4,300	4,300
Other Services & Charges	31,241	58,615	27,979	35,963	88,486	81,509
Capital Outlay	-	-	-	130,000	-	-
Operating Transfers	702	-	-	-	-	-
<i>Total Registrations</i>	100,414	148,977	101,800	265,938	183,924	180,571
<i>Percent Change From Previous Year</i>	18.1%	48.4%	-31.7%	161.2%	-30.8%	-1.8%
<i>Total Election Reserve Fund</i>	598,145	691,565	607,202	1,577,218	745,654	760,959
<i>Percent Change From Previous Year</i>	-25.4%	15.6%	-12.2%	159.8%	-52.7%	2.1%
166 AUDITOR'S O&M FUND						
Salaries & Wages	4,958	4,241	8,180	16,000	4,000	4,000
Benefits	490	397	766	550	550	550
Supplies	949	3,402	411	60,327	8,900	2,400
Other Services & Charges	8,664	5,750	500	196,823	26,767	23,667
Capital Outlay	7,776	15,256	4,004	122,988	5,000	-
Operating Transfers	-	-	19,171	37,864	74,712	79,393
<i>Total Auditor's O & M Fund</i>	22,837	29,046	33,032	434,552	119,929	110,010
<i>Percent Change From Previous Year</i>	-11.5%	27.2%	13.7%	1215.5%	-72.4%	-8.3%
TOTAL AUDITOR	1,453,236	1,546,704	1,578,379	2,969,008	1,895,625	1,944,188
<i>Percent Change From Previous Year</i>	-6.3%	6.4%	2.0%	88.1%	-36.2%	2.6%

Services

Internal Audit

Evaluate, make recommendations and report on county operations.

Document Recording

The County Auditor is the official recorder of property and other records within the county. Deeds, mortgages and other property contracts are recorded in this office and an official copy is maintained for public research and historical purposes.

Marriage Licenses

Issue, record and maintain marriage licenses as public records.

Licensing

License and process title transfers for vehicles and vessels; monitor licensing subagents.

Election Management

Maintain voter database and conduct elections held within Whatcom County and all political subdivisions.

County Council

The legislative branch of Whatcom County government, the County Council comprises seven elected part-time council members. The council meets regularly on every other Tuesday evening and enacts ordinances and resolutions, sets the county budgets, creates policies and hears appeals. Check the library, newspaper or the council office for schedules and agendas.

FTE's for this department

Year	2001	2002	2003	*2004	*2005	*2006	*budget
FTE	9.50	9.50	9.50	9.50	9.50	9.50	

The chart below shows the organizational structure for 2005 only.

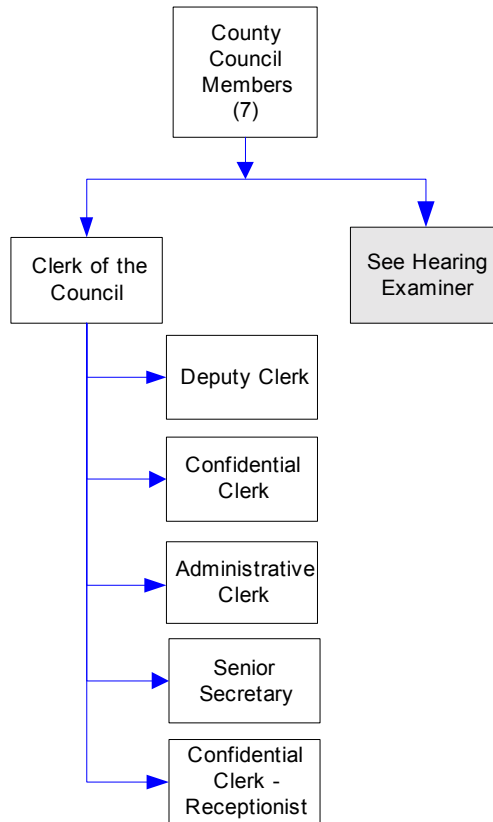

Mission & Objectives

Mission

The Whatcom County Council and its staff are dedicated to providing responsive representation and superior customer service through the creation of laws and policies that promote continual improvement to the health, safety, and welfare of all present and future Whatcom County citizens.

Objectives

- Continue to explore avenues for getting council-related information out to the public.

2005

- Provide assistance to the Whatcom County Charter Review Commission in its deliberation and drafting of proposed amendments to the Whatcom County Charter.
- Council records retention project - archive, microfilm, and catalog all records for 1999.
- Board of Equalization records retention project - archive, microfilm, and catalog records for 1993, 1994, and 1995.
- Train two additional staff members in procedures for posting council-related information to the web.
- Complete policy and procedure manual rewrite for the Deputy Clerk of the Council.
- Research cost and efficiency of new digital recording equipment for the Whatcom County Council Chambers.
- Prepare training for newly-elected council members (term of office beginning in January 2006).

- Assist the Hearing Examiner Coordinator in preparing records for archiving

2006

- Board of Equalization records retention project - archive, microfilm, and catalog records for 1996, 1997, and 1998.
- Council records retention project - archive, microfilm, and catalog all records for 2000.
- Complete policy and procedure manual rewrite for the Clerk of the Council.

Expenditure Trends

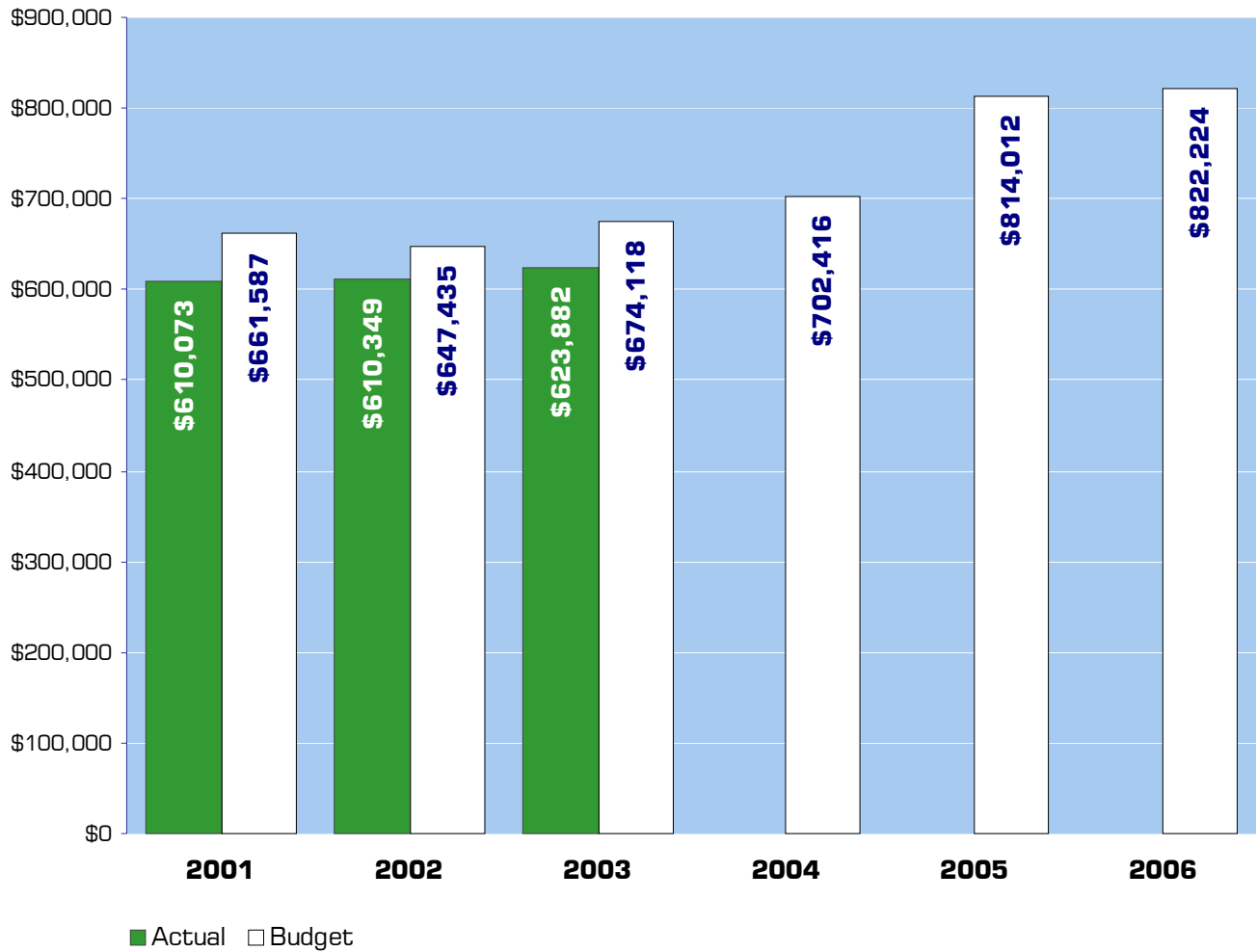

NOTE: Capital expenditures and interfund operating transfers are not shown to more accurately reflect ongoing operational costs.

2005-2006 Budget by Program

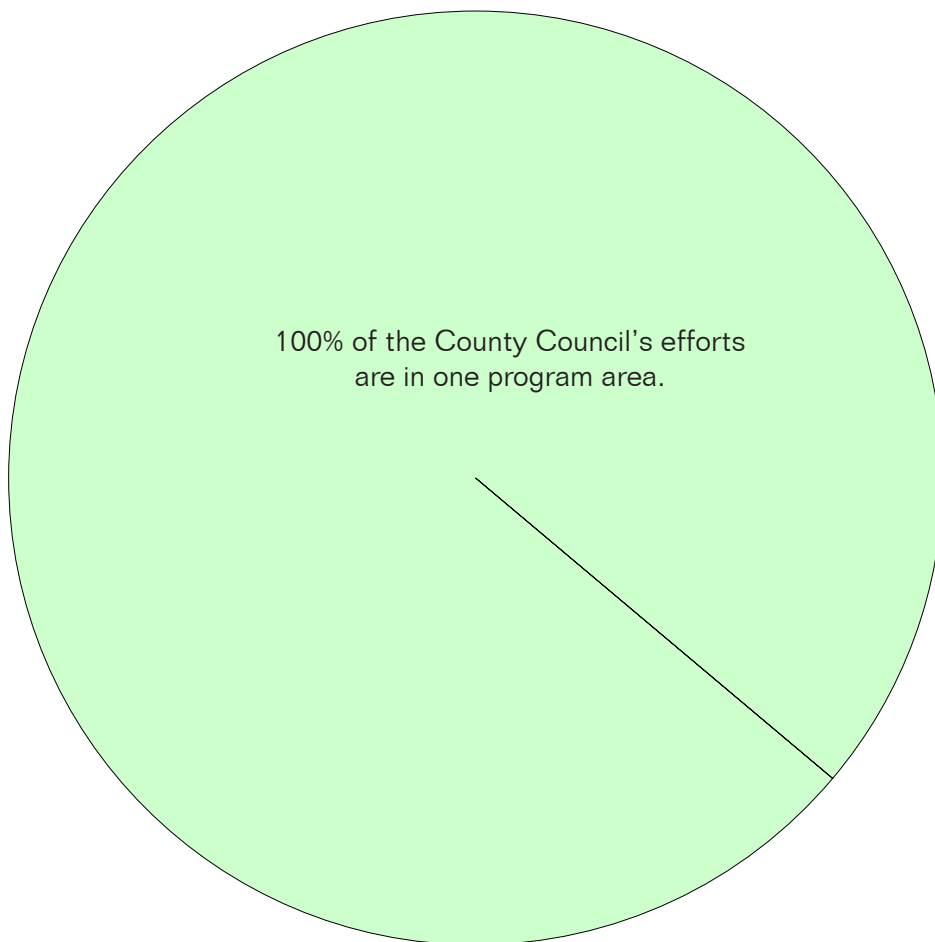

NOTE: Capital expenditures are not shown to more accurately reflect ongoing operational costs.

Program Summary

	Actual 2001	Actual 2002	Actual 2003	Budget 2004	Budget 2005	Budget 2006
OPERATIONS						
General Fund						
1100 County Council	602,210	603,828	616,922	702,416	798,012	822,224
1120 Board of Equalization	7,863	6,521	6,960	-	-	-
1130 Charter Review	-	-	-	-	16,000	-
<i>Total County Council Operations</i>	610,073	610,349	623,882	702,416	814,012	822,224
TRANSFERS						
General Fund						
1100 County Council	3,904	-	-	-	-	-
<i>Total County Council Transfers</i>	3,904	-	-	-	-	-
TOTAL COUNTY COUNCIL	613,977	610,349	623,882	702,416	814,012	822,224
<i>Percent Change from Previous Year</i>	9.0%	-0.6%	2.2%	12.6%	15.9%	1.0%

2005-2006 Funding Sources

	2005	2006
General Fund	809,988	818,200
Miscellaneous Revenue	4,024	4,024
Total Funding	814,012	822,224

General Fund

Undedicated General Fund resources.

Miscellaneous Revenue

Fees collected for photocopies, agenda and council packet subscriptions.

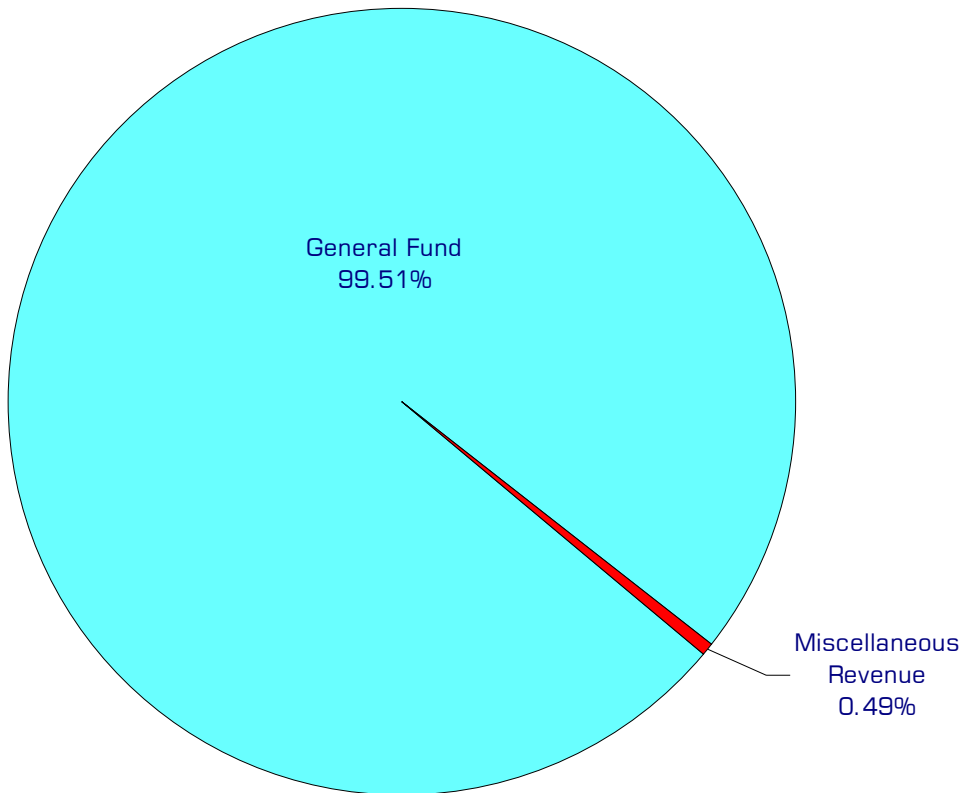

Performance / Activity Measures

	Actual 2001	Actual 2002	Actual 2003	Projected 2004	Projected 2005	Projected 2006
Agenda Bills Processed	520	530	504	500	520	520
Ordinances and Resolutions	160	141	157	165	180	180
Legal/Public Notices Prepared & Processed	200	259	253	275	320	320
Council Meetings Attended (regular and special)	45	57	50	50	50	50
Committee Meetings Attended	100	92	100	100	120	120
Pages of Minutes Transcribed	2,475	1,682	2,000	2,000	2,250	2,250
Correspondence Processed (includes e-mails) - beginning 2004	350	347	350	4,880	5,000	5,000
Board of Equalization Petitions Processed	450	310	210	300	300	300
Copies Made	154,000	157,000	150,000	150,000	165,000	165,000
Appeals Processed	5	5	8	5	5	5
Road Vacations Processed	2	1	3	2	2	2

Expenditures Summary

	Actual 2001	Actual 2002	Actual 2003	Budget 2004	Budget 2005	Budget 2006
GENERAL FUND						
1100 County Council						
Salaries & Wages	303,418	320,792	335,710	363,589	367,161	369,473
Benefits	143,318	126,780	129,239	147,223	164,473	180,908
Supplies	25,172	18,003	20,277	28,175	29,267	29,267
Other Services & Charges	130,302	138,253	131,696	163,429	237,111	242,576
Operating Transfers	3,904	-	-	-	-	-
<i>Total County Council</i>	606,114	603,828	616,922	702,416	798,012	822,224
<i>Percent Change from Previous Year</i>	8.4%	-0.4%	2.2%	13.9%	13.6%	3.0%
1120 Board of Equalization						
Salaries & Wages	6,075	5,625	5,475	-	-	-
Benefits	495	459	442	-	-	-
Supplies	242	46	24	-	-	-
Other Services & Charges	1,051	391	1,019	-	-	-
<i>Total Board of Equalization</i>	7,863	6,521	6,960	-	-	-
<i>Percent Change from Previous Year</i>	87.9%	-17.1%	6.7%	-100.0%	0.0%	0.0%
1130 Charter Review						
Other Services & Charges	-	-	-	-	16,000	-
<i>Total Charter Review</i>	-	-	-	-	16,000	-
<i>Percent Change from Previous Year</i>	-100.0%	0.0%	0.0%	0.0%	0.0%	-100.0%
TOTAL COUNTY COUNCIL	613,977	610,349	623,882	702,416	814,012	822,224
<i>Percent Change from Previous Year</i>	9.0%	-0.6%	2.2%	12.6%	15.9%	1.0%

Services

Council Meeting Requirements

Council staff to carry out all council-related meeting requirements.

Accounting and Payroll Services

Council, hearing examiner, and board of equalization accounting and payroll services.

Appeals

Process appeals to the council of final hearing examiner decisions and preparation of the official record for appeals of council decisions to Superior Court or other appropriate body.

Board & Commission Appointments

Ensures that vacant positions on Whatcom County boards, commissions, and committees are filled annually and upon resignation of members.

Correspondence and Document Processing and Retention

Drafting, processing, distribution and retention of all incoming and outgoing council member correspondence and council-related documentation.

Ordinance and Resolution Processing and Codification

Council staff members draft, process, and codify ordinances and resolutions in accordance with local and state law.

Reception

Provides all front line support for the council office.

Road Vacations

Assist in processing of requests for the vacation of county roads or portions thereof.

Board of Equalization

Provides the taxpayer with an appeal process to challenge the Assessor's determination of real property value.



District Court

With two elected judges and one appointed commissioner, District Court processes Sheriff, State Patrol, some City of Bellingham, Department of Fisheries, State Park and WWU traffic citations. It also handles small claims, civil claims, name changes and protection orders (as referred by Superior Court).

FTE's for this department

Year	2001	2002	2003	*2004	*2005	*2006
FTE	16.00	16.00	16.00	17.00	18.00	18.00

**budget*

The chart below shows the organizational structure for 2005 only.

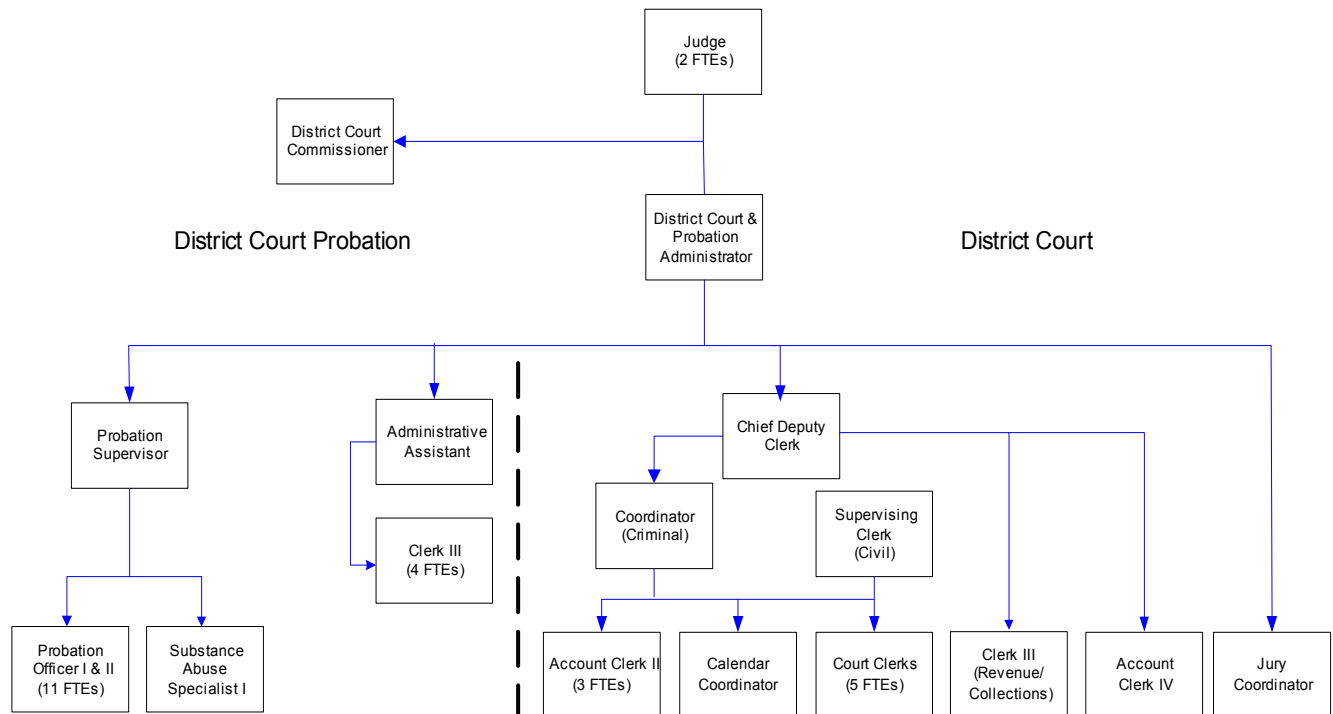

Mission & Objectives

Mission

Provide fair and equal access to all members of the public to services provided by District Court. Develop and maintain systems and policies that provide for outstanding service to the public. Hear and determine criminal cases involving misdemeanors and gross misdemeanors.

Additionally, District Court has jurisdiction over civil matters in which the amount in controversy does not exceed \$50,000. Small Claims Court, which is a subsection of District Court, has jurisdiction concurrent with the District Court over civil matters in which the controversy is \$4,000 or less. Traffic and non-traffic infraction cases, domestic violence and anti-harassment orders for protection are also heard in District Court. Collect all fines and fees assessed by the court.

Objectives

- Create complete desk manuals for the following District Court positions by December, 2005:
 - A. Calendar Coordinator
 - B. Courtroom Clerk
 - C. Account Clerk IV
- Create a complete desk manual for the District Court Civil Department by December, 2006.
- Implement a "Supervisors' Checklist" by January, 2005.
- The following internal audits will be completed monthly by the Chief Deputy Clerk:
 1. Restitution Out of Balance Audit Report
 2. Restitution Adjustments Audit Report
 3. Non-Cash Credit Audit Report
 4. Accounts Payable Adjustment Audit Exception Report
 5. Adjusted Receipt Audit Report
 6. Accounts Receivable Adjustment Audit Report
 7. Overpayment Report
 8. Deleted Cases Report
- Complete a review of the applicable records retention schedule, and transfer appropriate accounting and jury documents to off-site storage by June, 2005.

Expenditure Trends

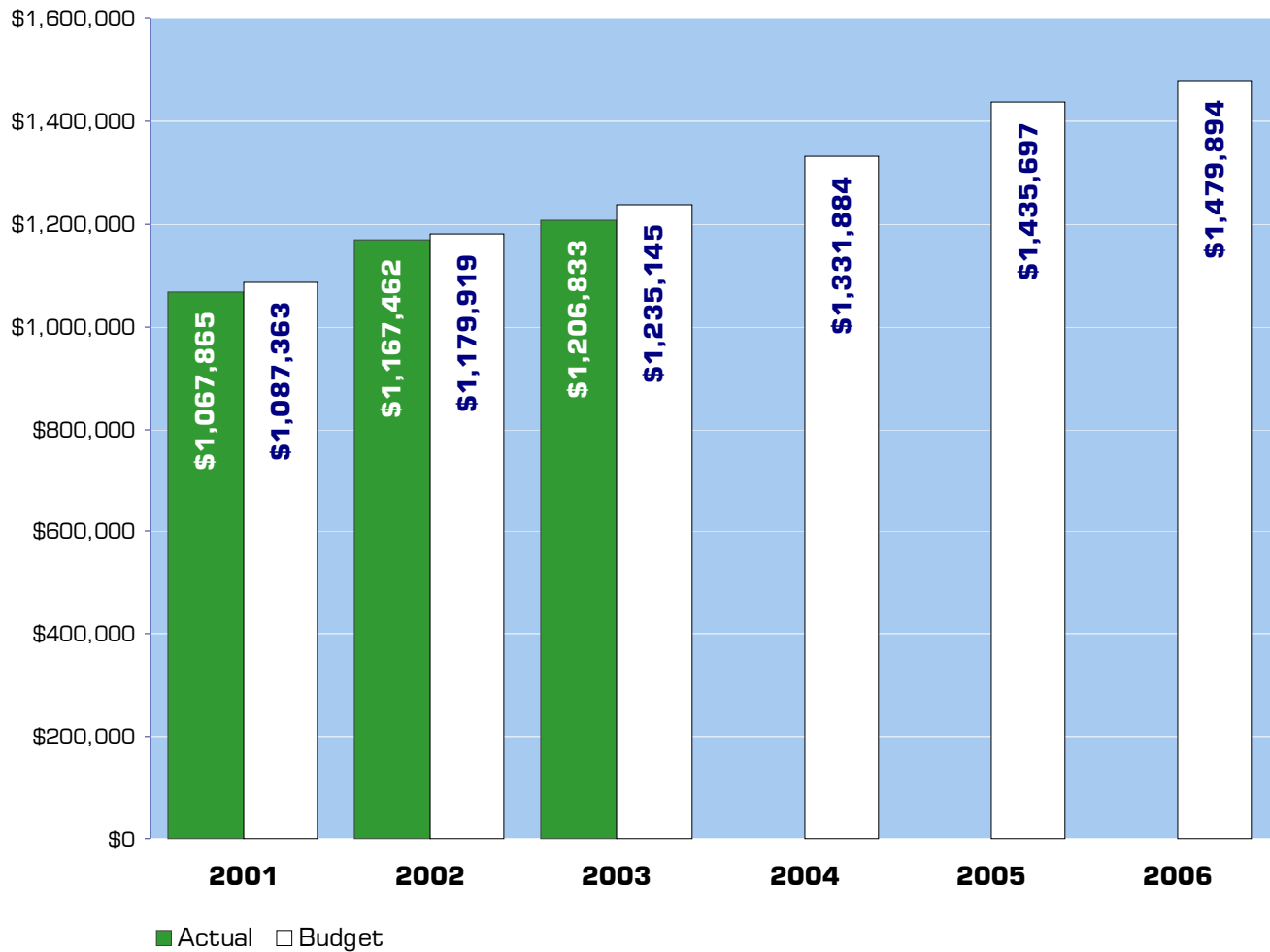

NOTE: Capital expenditures and interfund operating transfers are not shown to more accurately reflect ongoing operational costs.

2005-2006 Budget by Program

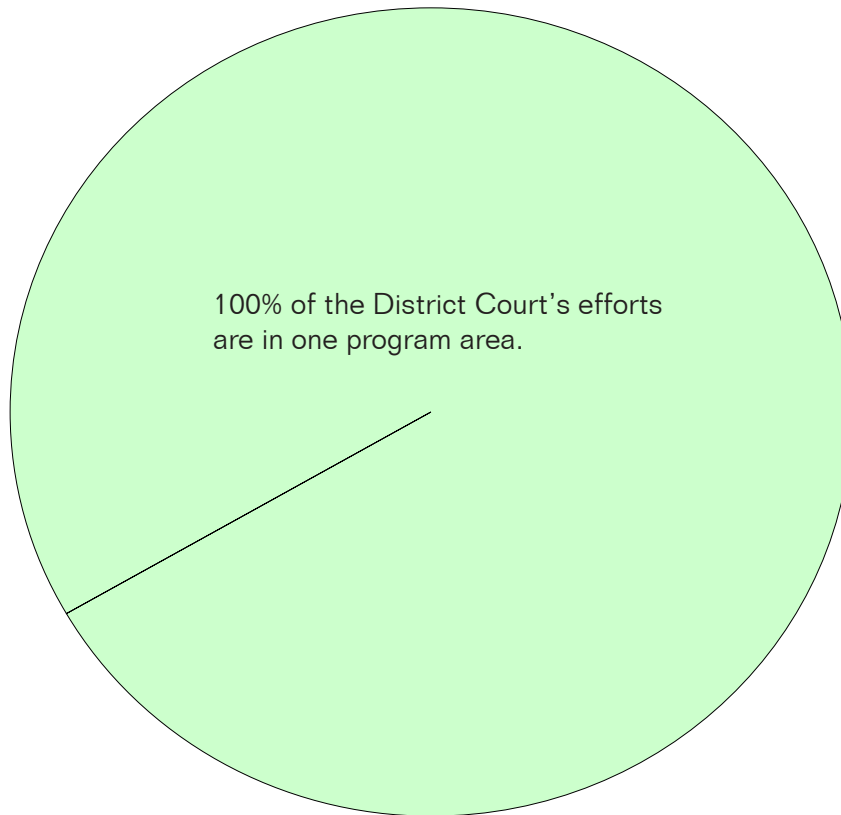

NOTE: Capital expenditures are not shown to more accurately reflect ongoing operational costs.

Program Summary

Actual 2001	Actual 2002	Actual 2003	Budget 2004	Budget 2005	Budget 2006
----------------	----------------	----------------	----------------	----------------	----------------

OPERATIONS

General Fund

1300 District Court	1,067,865	1,167,462	1,206,833	1,331,884	1,435,697	1,479,894
<i>Total District Court Operations</i>	1,067,865	1,167,462	1,206,833	1,331,884	1,435,697	1,479,894

CAPITAL

General Fund

1300 District Court	-	-	7,589	-	45,835	-
<i>Total District Court Capital</i>	-	-	7,589	-	45,835	-

TRANSFERS

General Fund

1300 District Court	9,169	-	-	-	-	-
<i>Total District Court Transfers</i>	9,169	-	-	-	-	-

TOTAL DISTRICT COURT	1,077,034	1,167,462	1,214,422	1,331,884	1,481,532	1,479,894
<i>Percent change from previous year</i>	8.2%	8.4%	4.0%	9.7%	11.2%	-0.1%

2005-2006 Funding Sources

	2005	2006
Service Charges & Fees	114,850	114,850
General Fund	1,320,847	1,365,044
Total Funding	1,435,697	1,479,894

Service Charges & Fees

District Court charges for transcripts, warrants, filing and various other services. Judicial fines and forfeits are not included as District Court revenue.

General Fund

Undedicated General Fund resources.

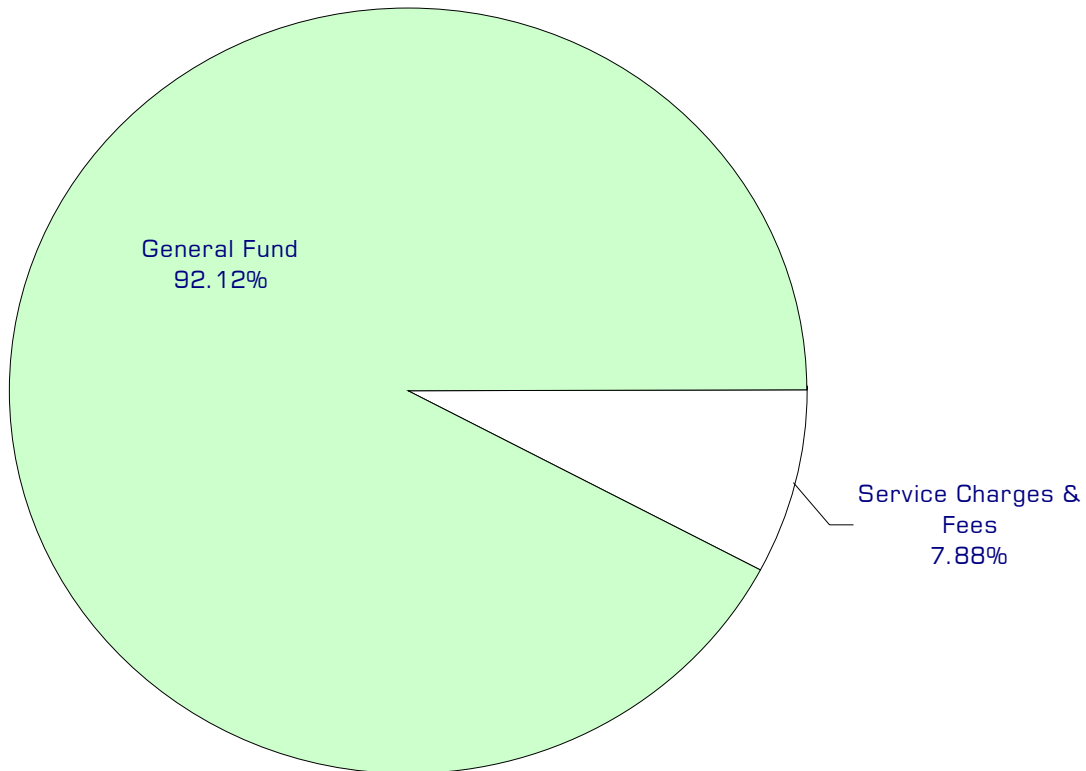

Performance / Activity Measures

	Actual 2001	Actual 2002	Actual 2003	Projected 2004	Projected 2005	Projected 2006
Infractions	11,597	16,412	17,810	18,500	19,500	20,000
DUI	739	927	973	1,000	950	950
Other Criminal Traffic	1,445	1,726	1,806	1,200	1,000	1,000
Criminal	1,555	1,706	1,468	1,700	1,700	1,700
Civil	4,563	4,502	4,541	4,400	4,500	4,500

Expenditures Summary

	Actual 2001	Actual 2002	Actual 2003	Budget 2004	Budget 2005	Budget 2006
GENERAL FUND						
1300 District Court						
Salaries & Wages	695,443	762,184	801,762	862,240	881,219	897,532
Benefits	170,902	174,723	192,422	216,045	278,231	310,998
Supplies	28,549	31,379	27,954	22,600	30,384	22,884
Other Services & Charges	172,971	199,176	184,695	230,999	245,863	248,480
Capital Outlay	-	-	7,589	-	45,835	-
Operating Transfers	9,169	-	-	-	-	-
<i>TOTAL DISTRICT COURT</i>	1,077,034	1,167,462	1,214,422	1,331,884	1,481,532	1,479,894
<i>Percent Change from Previous Year</i>	8.2%	8.4%	4.0%	9.7%	11.2%	-0.1%

Services

Criminal & gross misdemeanor (DUI, Criminal Traffic)

Trials, probation, collection of fines and fees, jury coordination, criminal orders for protection, warrants for arrest.

District Court Civil Cases

Small Claims Trials & Post Judgment Filings; Civil Trials & Post Judgment Hearings & Filings; Name Change Orders; Civil Orders for Protection, Domestic & Anti Harassment.

District Court Infractions

Contested hearings and collection of penalties.



District Court Probation

This department provides adult probation services for offenders charged with misdemeanors in the District Court and some municipal courts that contract with the county. This office does not supervise offenders convicted of felonies in the Superior Court (these are handled by the state probation office).

FTE's for this department

Year	2001	2002	2003	*2004	*2005	*2006	<i>*budget</i>
FTE	17.00	18.00	18.00	18.00	19.00	19.00	

See District Court section for organization chart.

Mission & Objectives

Mission

Provide adult misdemeanor probation services to District, Superior, Everson, Lynden, Sumas, and Bellingham courts. The Probation Department is an arm of the court, serving and fulfilling the requests of the Judges. These services increase public and victim safety by holding offenders accountable for their crimes, reduce the cost of incarcerating offenders in jail, and provide offenders the opportunity to obtain treatment for their behavior or addiction that contributed to their criminal offense, that they may become more productive members of society. The department coordinates offenders' supervision, evaluation, and treatment with all outside community resources, including, but not limited to, alcohol/drug, batterers, and mental health treatment.

Objectives

Alcohol/Drug Unit

- Complete accurate alcohol/drug assessment and refer clients to treatment services that are appropriate for their needs.
- Measure quality of services by surveying local treatment agencies at least one time per year to gather the following information:
 - a. Did you agree with the treatment diagnosis recommended?
 - b. Was the assessment information useful in treatment planning?

Alternately, analyze "requests for change in level of service" submitted by the treatment agencies. Success will be based on a 80% or more positive response from the agencies.

- Provide timely alcohol/drug assessments for the court, attorneys and probation services. Upon proof of payment, 90% of all assessment appointments will be scheduled within 4 weeks.
- Increase the number of alcohol/drug assessments by 10% in 2005.

Domestic Violence Unit

- Gather and compile statistical information on domestic violence cases to show possible variations in outcomes when comparing the Domestic Violence Unit to the main probation population.

Track approximately 200 domestic violence cases to show possible variations in outcomes when comparing the Domestic Violence Unit and 200 from the main probation population to review recidivism rates and monitor compliance issues.

Work with the University of Washington and the Administrative Office of the Courts to compile results of the statistical information by September of 2006.

- Provide support to domestic violence victims through volunteer support.

Provide at least 4 hours of volunteer work per week to victims of domestic violence. The primary use of this volunteer time will be to inform victims of available resources.

Probation

- Provide accurate monitoring of court ordered conditions for all courts served by the Department. Randomly review the following monthly audit reports for each probation officer's caseload:

- a. Referrals due to close
- b. Treatment reports 75 days overdue
- c. File reviews: no chronological entry, personal contact or court action in 3 months.

Review 6 to 10 cases per month, per probation officer, to ensure compliance with all present policies and procedures.

Monitor caseload levels to ensure that caseloads are equally balanced between officers.

Review caseload sizes with the Judges as levels increase. (Total probation cases as of July 20, 2004: 3177 cases; Average per probation officer as of July 20, 2004: 317 cases.)

- Provide timely services to individuals referred to probation by the court.
 - a. 90 % of all assault cases will be scheduled within two weeks.
 - b. 90% of all DUI cases will be scheduled within one month.
 - c. 90% of all Domestic Violence Unit cases will be scheduled within five working days.

- Create efficient and effective communication between local treatment agencies and Whatcom County District Court Probation.

Meet with the alcohol/drug treatment agencies in Whatcom County quarterly and review and update the memorandum of understanding yearly (March 2005, 2006).

Meet quarterly with the Whatcom County batterer's treatment agencies and review and update the memorandum of understanding yearly (June 2005, 2006).

- Update policy manual to ensure consistency in the department and to lower legal liability for the probation staff and the county.
- Create and update standard policy and procedures for reporting violations to the court. They will include, at a minimum, the following topic areas:
 - a. Reporting alcohol/drug relapse
 - b. Reporting violations of the law
 - c. Monitoring Disulfiram (Antabuse) requirement
 - d. Supervision requirements based on risk
- Coordinate use of community resources with probation services to provide efficient and effective communication between these systems. Invite one local agency at least every other month to present their services to probation staff.

Expenditure Trends

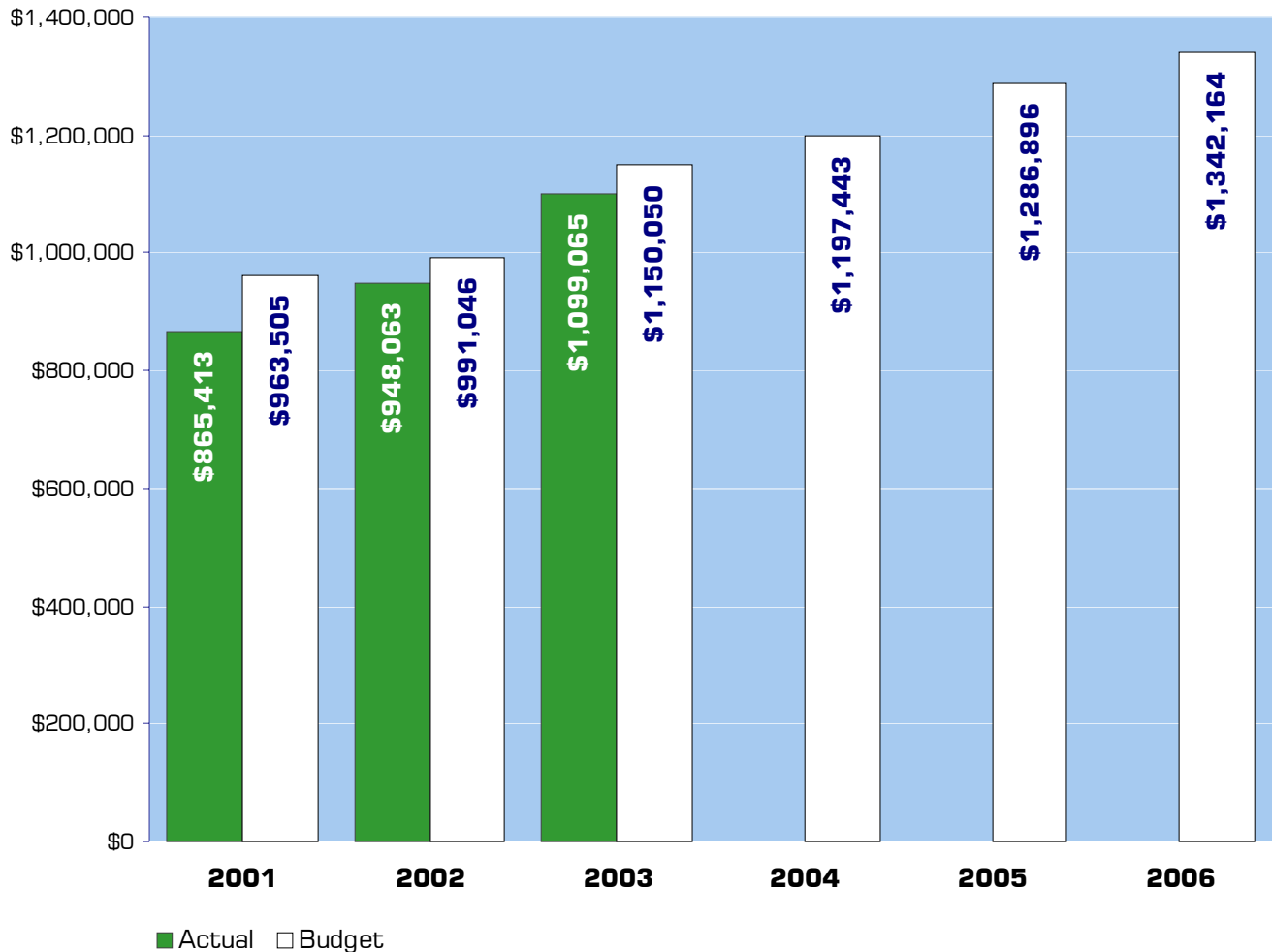

NOTE: Capital expenditures and interfund operating transfers are not shown to more accurately reflect ongoing operational costs.

2005-2006 Budget by Program

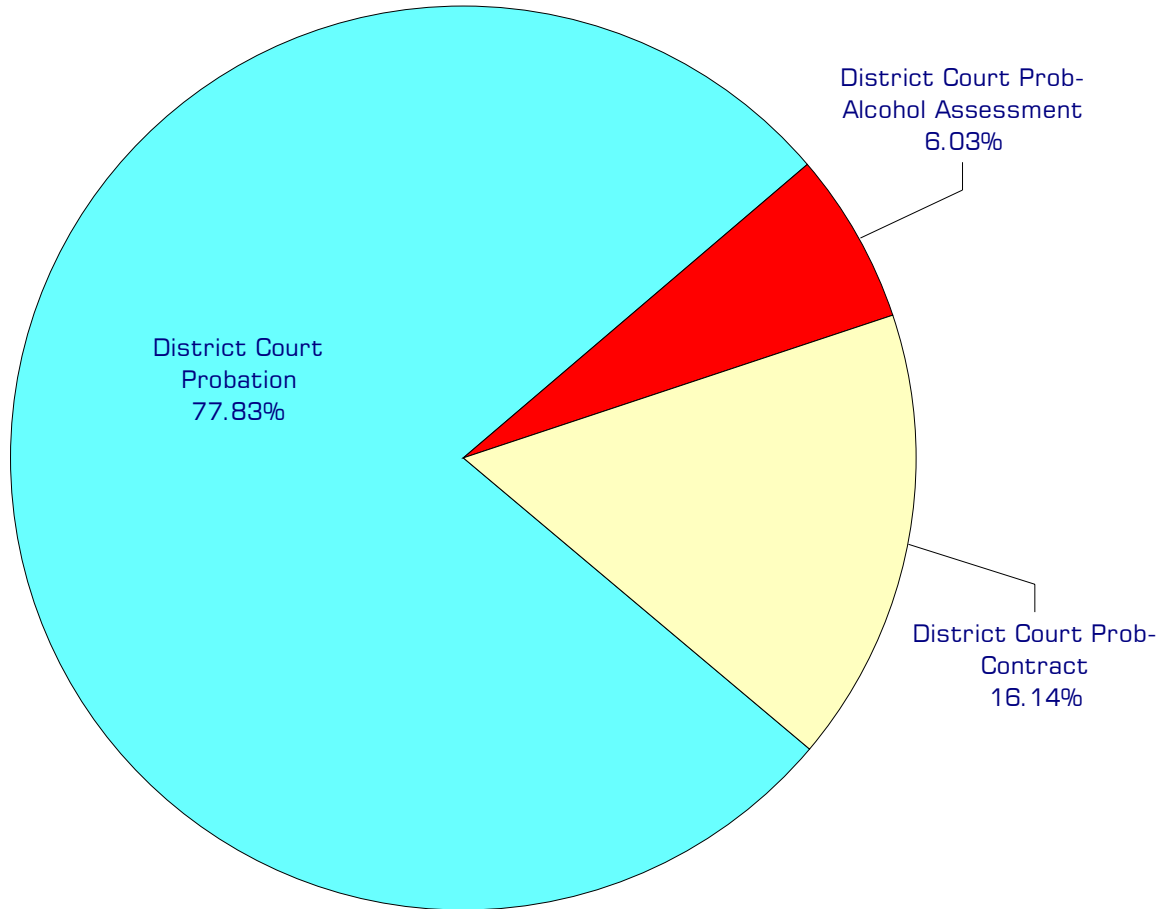

NOTE: Capital expenditures are not shown to more accurately reflect ongoing operational costs.

Program Summary

Actual 2001	Actual 2002	Actual 2003	Budget 2004	Budget 2005	Budget 2006
----------------	----------------	----------------	----------------	----------------	----------------

OPERATIONS

General Fund

1310 Dist Court Probation	708,000	805,851	879,686	918,125	1,002,298	1,043,824
1311 Dist Ct Prob-Alcohol Assment	-	6,576	39,730	86,819	77,687	80,904
1312 Dist Court Prob- Contract	157,413	135,636	179,649	192,499	206,911	217,436
<i>Total Dist Court Probation Operations</i>	865,413	948,063	1,099,065	1,197,443	1,286,896	1,342,164

CAPITAL

General Fund

1310 Dist Court Probation	-	-	-	-	12,586	-
1312 Dist Court Prob- Contract	1,667	-	-	-	-	-
<i>Total Dist Court Probation Capital</i>	1,667	-	-	-	12,586	-

TRANSFERS

General Fund

1310 District Court Probation	6,764	-	-	-	-	-
<i>Total Dist Court Probation Transfers</i>	6,764	-	-	-	-	-

TOTAL DIST COURT PROBATION	873,844	948,063	1,099,065	1,197,443	1,299,482	1,342,164
<i>Percent Change from Previous Year</i>	5.1%	8.5%	15.9%	9.0%	8.5%	3.3%

2005-2006 Funding Sources

	2005	2005
General Fund	54,377	59,645
Adult Probation Service Fee	755,700	805,700
Substance Abuse Service Fee	86,819	86,819
Intergovernmental Services	390,000	390,000
Total Funding	1,286,896	1,342,164

General Fund

Undedicated General Fund resources.

Adult Probation Service Fee

Services fees are paid by adult probationers to cover part of the cost of their supervision.

Substance Abuse Service Fee

Service fees are paid by DUI offenders to cover the cost of court ordered substance abuse evaluations.

Intergovernmental Services

Revenue received from local cities to handle adult probation cases.

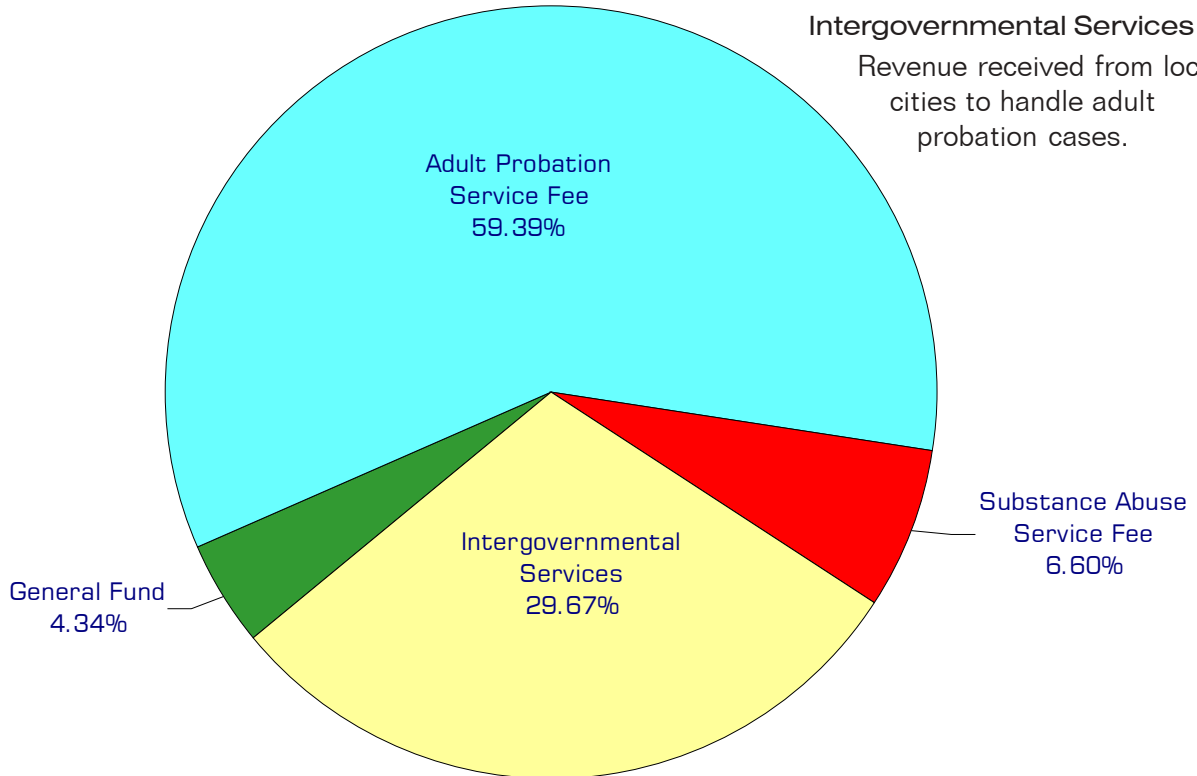

Performance / Activity Measures

	Actual 2001	Actual 2002	Actual 2003	Projected 2004	Projected 2005	Projected 2006
Caseloads per Probation Officer	255	230	261	305	330	356
Court ordered urinalysis tests	2,821	3,760	3,959	5,000	5,500	6,000

Expenditures Summary

	Actual 2001	Actual 2002	Actual 2003	Budget 2004	Budget 2005	Budget 2006
GENERAL FUND						
1310 District Court Probation						
Salaries & Wages	470,922	547,477	603,066	621,093	661,235	677,202
Benefits	124,687	137,579	157,533	174,255	208,833	234,270
Supplies	9,544	9,069	7,625	8,000	11,475	8,000
Other Services & Charges	102,847	111,726	111,462	114,777	120,755	124,352
Capital Outlay	-	-	-	-	12,586	-
Operating Transfers	6,764	-	-	-	-	-
<i>Total District Court Probation</i>	<i>714,764</i>	<i>805,851</i>	<i>879,686</i>	<i>918,125</i>	<i>1,014,884</i>	<i>1,043,824</i>
<i>Percent Change from Previous Year</i>	<i>5.5%</i>	<i>12.7%</i>	<i>9.2%</i>	<i>4.4%</i>	<i>10.5%</i>	<i>2.9%</i>
1311 District Court Prob.-Alcohol Assessment						
Salaries & Wages	-	6,378	23,557	55,136	45,200	46,484
Benefits	-	198	2,693	13,658	14,120	15,654
Supplies	-	-	1,548	1,784	1,784	1,784
Other Services & Charges	-	-	11,932	16,241	16,583	16,982
<i>Tot Dst Ct Prob-Alcohol Assess</i>	<i>-</i>	<i>6,576</i>	<i>39,730</i>	<i>86,819</i>	<i>77,687</i>	<i>80,904</i>
<i>Percent Change from Previous Year</i>	<i>0.0%</i>	<i>0.0%</i>	<i>504.2%</i>	<i>118.5%</i>	<i>-10.5%</i>	<i>4.1%</i>
1312 District Court Probation- Contract						
Salaries & Wages	104,964	87,928	117,768	127,119	132,436	137,656
Benefits	28,634	20,760	32,741	36,905	42,000	47,305
Supplies	1,268	1,156	1,423	1,700	1,700	1,700
Other Services & Charges	22,547	25,792	27,717	26,775	30,775	30,775
Capital Outlay	1,667	-	-	-	-	-
<i>Total Dst Ct Prob-Contract</i>	<i>159,080</i>	<i>135,636</i>	<i>179,649</i>	<i>192,499</i>	<i>206,911</i>	<i>217,436</i>
<i>Percent Change from Previous Year</i>	<i>3.3%</i>	<i>-14.7%</i>	<i>32.4%</i>	<i>7.2%</i>	<i>7.5%</i>	<i>5.1%</i>
TOTAL DISTRICT CT. PROB.	873,844	948,063	1,099,065	1,197,443	1,299,482	1,342,164
<i>Percent Change from Previous Year</i>	<i>5.1%</i>	<i>8.5%</i>	<i>15.9%</i>	<i>9.0%</i>	<i>8.5%</i>	<i>3.3%</i>

Services

Deferred Prosecution (Probation)

Monitor compliance with conditions of Deferred Prosecution. Bring to the attention of the courts any noncompliance with Deferred Prosecution conditions. Make recommendations to the courts when changes in the conditions are necessary. Coordinate with the service providers in the community.

Pre-Trial Probation

Monitor Defendant for compliance with conditions of release, pending trial date. These cases usually require intensive supervision.

Probation Supervision

Supervision of individuals placed on court-ordered probation.

Assessment Unit

Provide court ordered substance abuse assessments for offenders charged with alcohol/drug related offenses.

Probation, City Contracts

Municipal courts of Sumas, Lynden, Everson-Nooksack and Bellingham contract for probation, deferred prosecution and pre-trial services.

County Executive's Office

An elected official, the County Executive manages the day-to-day functions of administrative departments. The Executive is responsible for quarterly and annual revenue estimation and tracking; recommends the county's annual budget to the County Council and monitors all departments' expenditures to ensure budget compliance. The Executive appoints members to boards and commissions, responds to citizen concerns, complaints and requests, and represents the county at local, regional, state and federal levels. The Executive is also responsible for managing all "non-departmental" services that the county provides.

FTE's for this department

Year	2001	2002	2003	*2004	*2005	*2006
FTE	4.50	4.50	4.50	4.50	4.50	4.50

**budget*

The chart below shows the organizational structure for 2005 only.

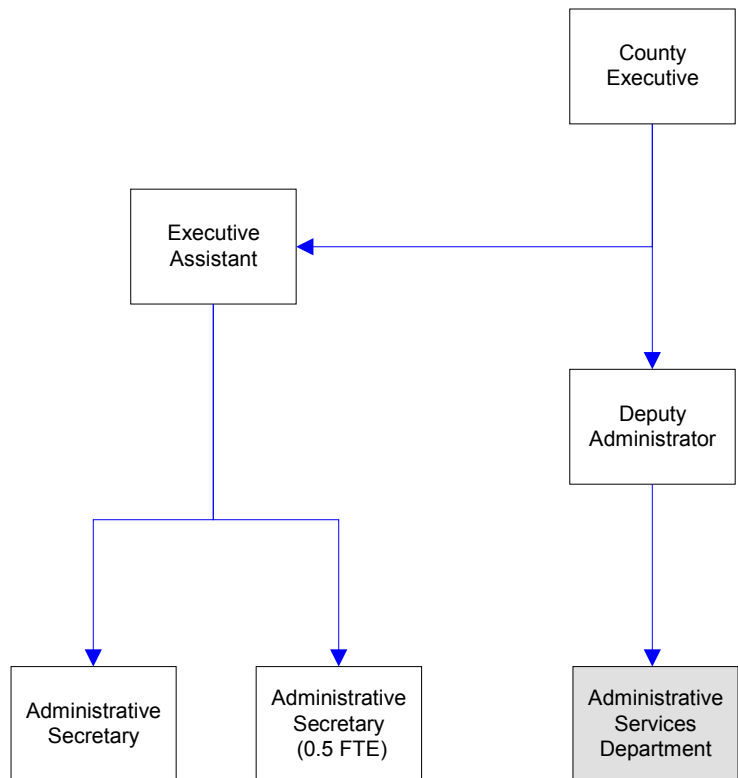

Mission & Objectives

Mission

Coordinate and provide for the most effective, efficient, and responsive public service operation for all facets of county government through sound management and strategic direction, execution and enforcement of all ordinances and appropriate state statutes within the county, exercising of all executive powers not expressly vested in other elective officers, protecting the public trust, and promoting the well-being of the citizens of Whatcom County.

Objectives

- Complete the design, planning and construction of a temporary minimum-security jail facility, community corrections and triage center.
- Work with Fire Districts, Fire Commissioners, and the cities of Whatcom County to provide an innovative Emergency Medical Service plan for all of Whatcom County.
- Meet with county departments to discuss and make recommendations regarding water resource issues.
- Meet at least once a month with Department Heads and Elected Officials to share information and develop enhanced teamwork.
- Meet at least six times with each Council member to share and adjust as necessary the Administration's goals and objectives for Whatcom County.
- Set up opportunities for citizens to meet individually or as a group with County Executive to share concerns.
- Complete the Whatcom County Master Facilities Plan.

Expenditure Trends

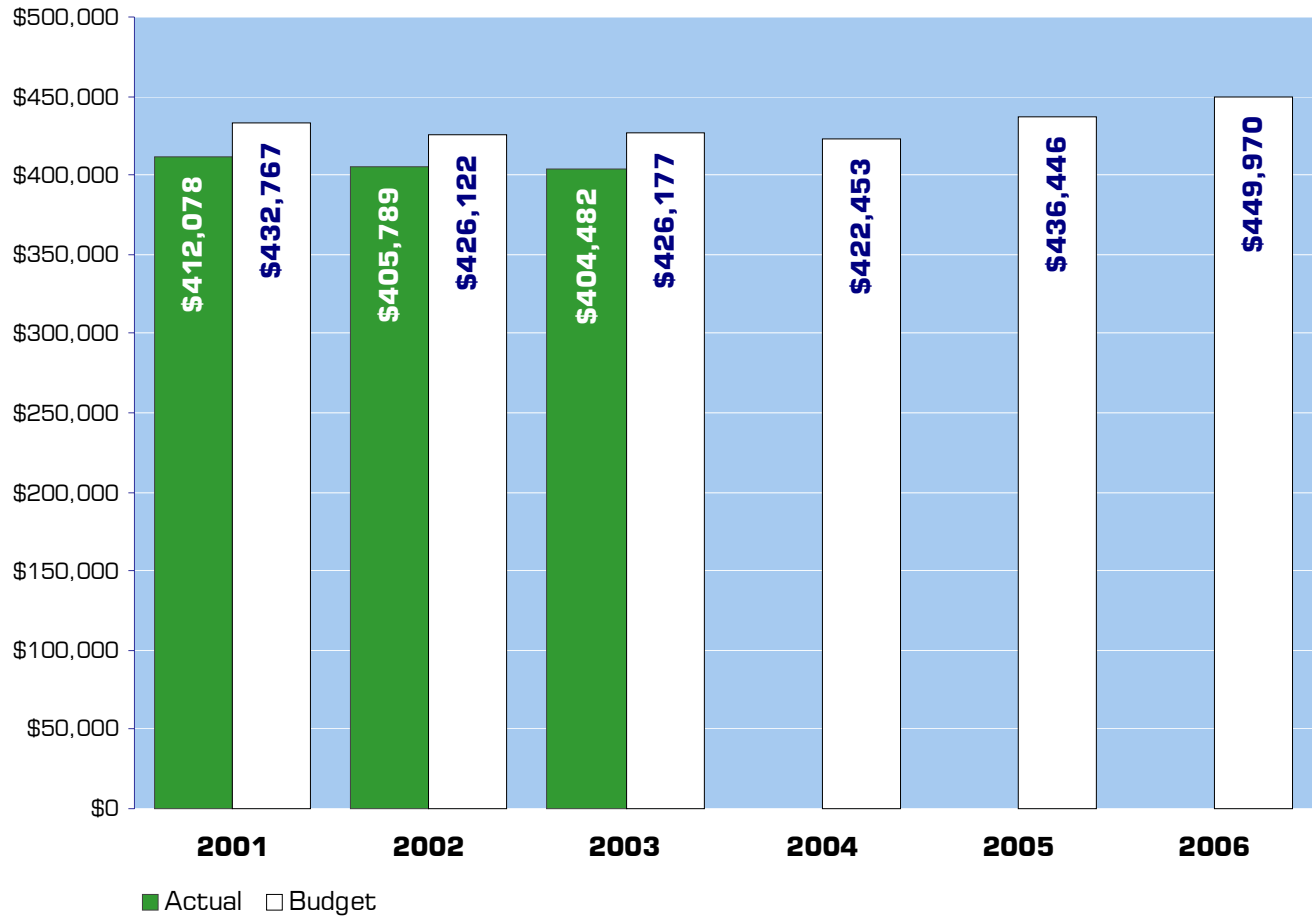

NOTE: Capital expenditures and interfund operating transfers are not shown to more accurately reflect ongoing operational costs.

2005-2006 Budget by Program

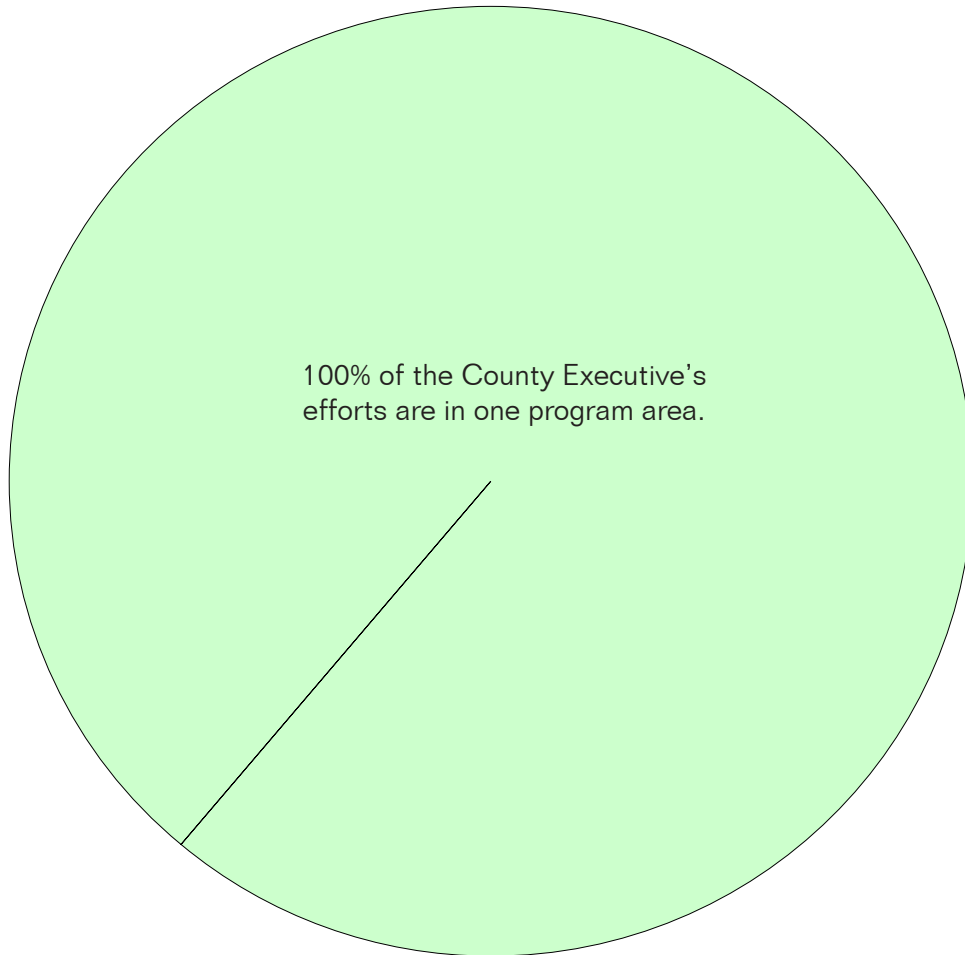

NOTE: Capital expenditures and interfund operating and residual equity transfers are not shown to more accurately reflect ongoing operational costs.

Program Summary

	Actual 2001	Actual 2002	Actual 2003	Budget 2004	Budget 2005	Budget 2006
OPERATIONS						
General Fund						
1200 County Executive	412,078	405,789	404,482	422,453	436,446	449,970
<i>Total Executive Operations</i>	412,078	405,789	404,482	422,453	436,446	449,970
TRANSFERS						
General Fund						
1200 County Executive	3,809	-	-	-	-	-
<i>Total Executive Transfers</i>	3,809	-	-	-	-	-
TOTAL EXECUTIVE	415,887	405,789	404,482	422,453	436,446	449,970
<i>Percent Change from Previous Year</i>	11.1%	-2.4%	-0.3%	4.4%	3.3%	3.1%

2005-2006 Funding Sources

	2005	2006
General Fund	436,446	449,970
Total Funding	436,446	449,970

General Fund

Undedicated General Fund resources.

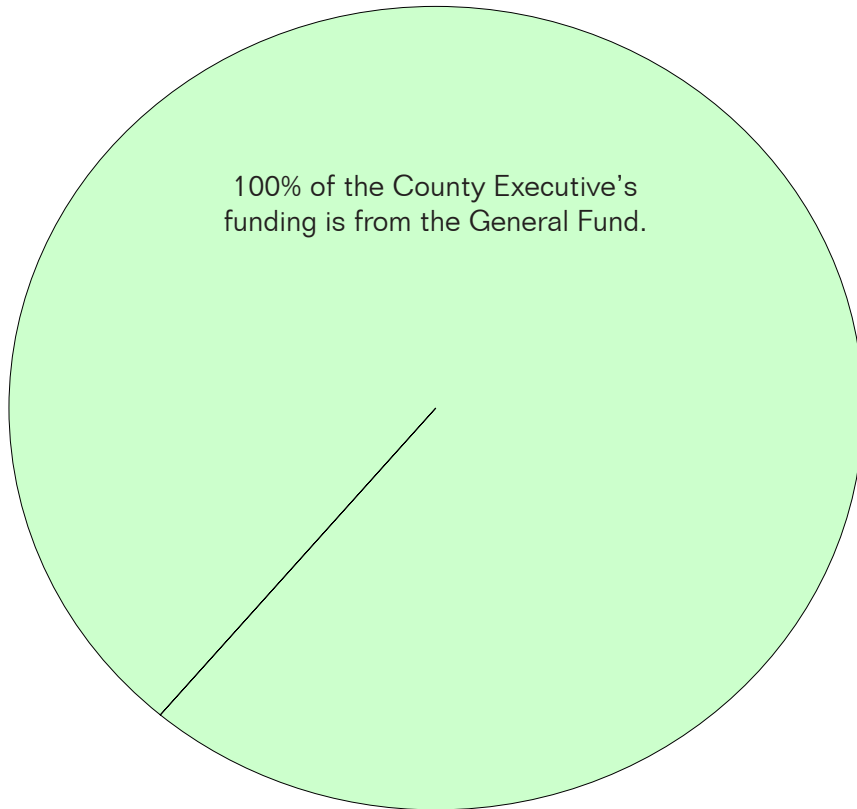

Expenditures Summary

	Actual 2001	Actual 2002	Actual 2003	Budget 2004	Budget 2005	Budget 2006
GENERAL FUND						
1200 County Executive						
Salaries & Wages	290,980	287,491	285,475	280,452	287,437	290,789
Benefits	68,159	63,418	57,868	63,807	73,671	82,799
Supplies	3,666	2,696	4,491	12,150	9,150	9,150
Other Services & Charges	49,273	52,184	56,648	66,044	66,188	67,232
Operating Transfers	3,809	-	-	-	-	-
<i>TOTAL COUNTY EXECUTIVE</i>	415,887	405,789	404,482	422,453	436,446	449,970
<i>Percent Change from Previous Year</i>	11.1%	-2.4%	-0.3%	4.4%	3.3%	3.1%

Services

Administration of County Departments

Administration and supervision of county departments to assure coordinated delivery of services to the citizens of Whatcom County at acceptable levels and through appropriate methods.

Budget Administration

Oversee development of budgets for all county operations. Ensure that the County Council is presented with balanced budgets that meet established policies regarding the funding of public services through county government. The Executive is responsible for ensuring that budgets are properly administered in conformance with legal mandates and the policy direction of the Council.

County Contracts & Agreements

Ensure that all contracts and agreements are properly formulated, negotiated, approved and administered so that the intent of said agreements may be properly and fully realized.

Executive Support Services

Provide support for the Executive, in the administration of the department as well as his role of County Executive, by providing coordination and communication between divisions and the public.

Financial Administration

Provide for proper administration and oversight of all financial matters and aspects of county government at all levels of county organization.

Personnel Administration

Administer and oversee all department head administrative personnel in selection, hiring supervision and where necessary, separation.

Public Service

Provide direct service to the public. Ensure appropriate response to a wide variety of requests, expressions of concern and complaints from persons, organizations and other governments regarding all facets of the county's operations.

Non-Departmental

“Non-Departmental” expenditures are administered by the County Executive’s Office. These expenditures include costs that are not attributable to specific program areas or departments.

There are no FTE’s in Non-Departmental.

Expenditure Trends

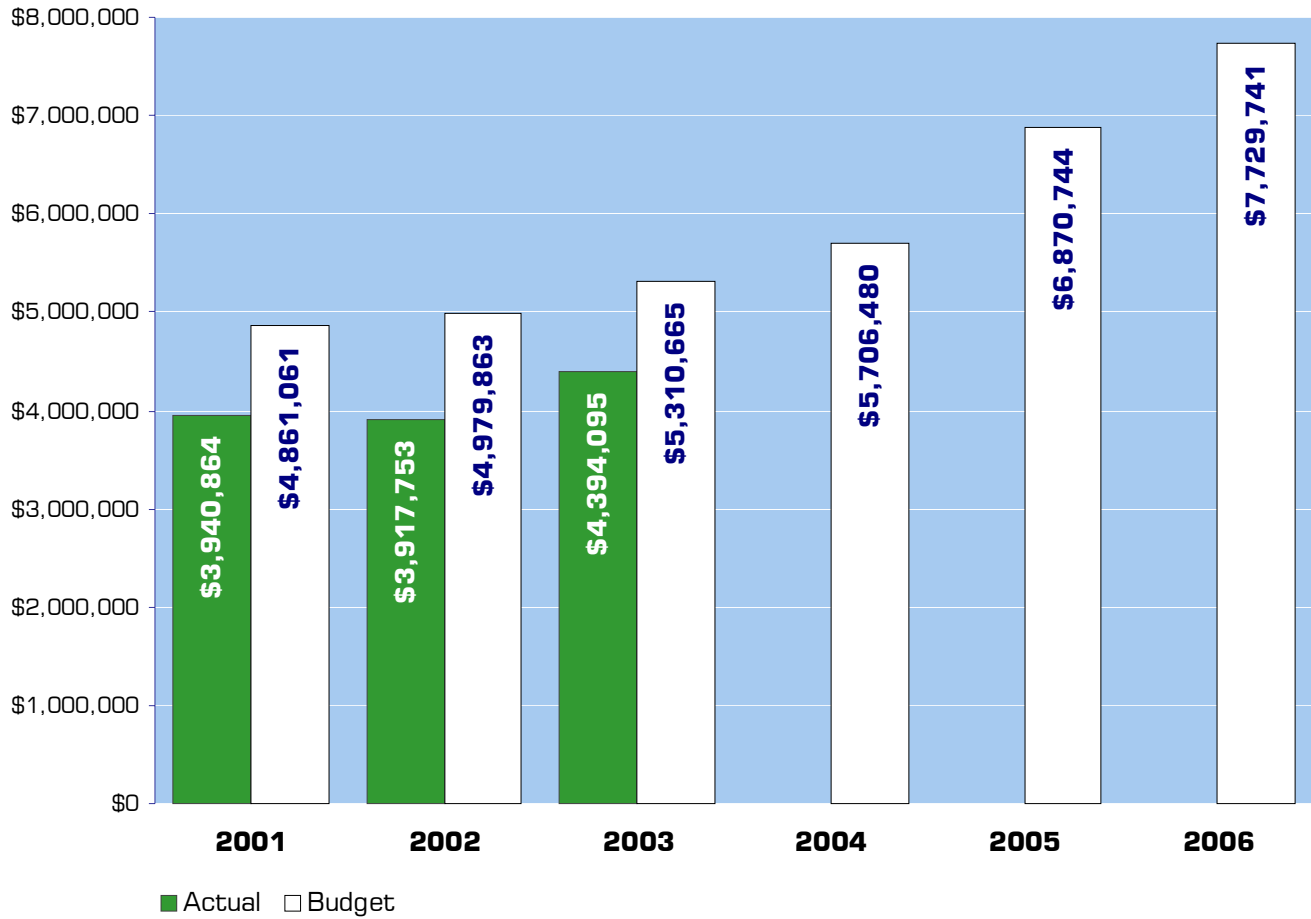

NOTES: Capital expenditures and interfund operating transfers are not shown to more accurately reflect ongoing operational costs.

2005-2006 Budget by Program

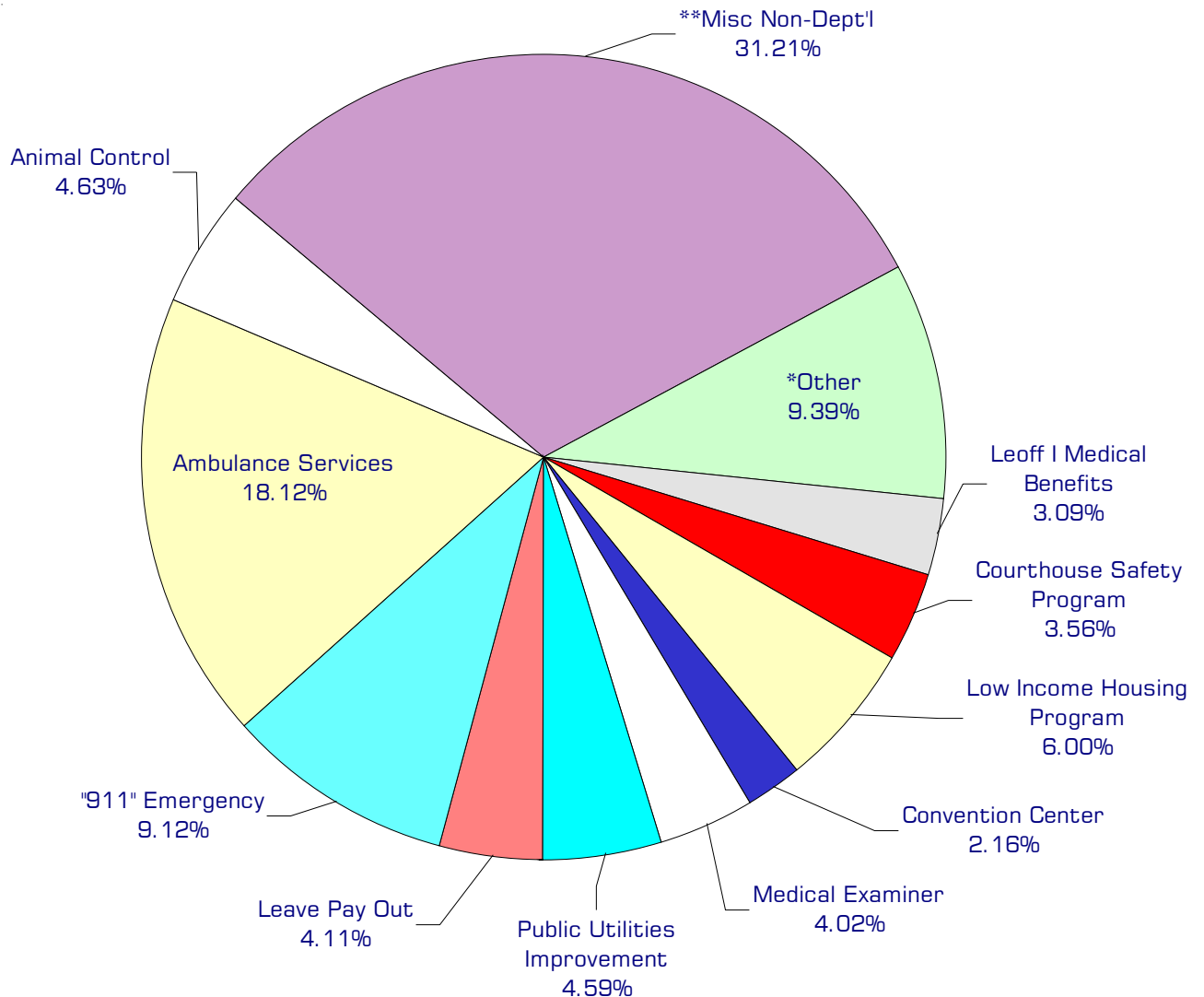

Note: Capital expenditures & interfund operating transfers are not shown to more accurately reflect ongoing operational costs.

***Other" comprises funding for: Indigent Burial, County Morgue, Criminal Justice Data Integration, Strategic Planning, Public Health/Home Health, Employee Recognition, Association Dues, Horticultural Inspection, Law & Justice Strategic Plan, LEOFF Board, Domestic Violence, Annual State Audit, Music and Art, Northwest Regional Council, Air Pollution Control, Pest Control, Volunteer Support, Planning/Com Dev COG, Boundary Review, Readiness to Learn, Starling program, Sister County Project, Water Conservancy Board, Economic Development, Lydia Place, and Conservation Futures.*

***Miscellaneous Non-Departmental comprises funds set aside for wage negotiation settlements, funds to establish a collections effort for court-mandated legal financial obligations, and various small items.*

Program Summary

	Actual 2001	Actual 2002	Actual 2003	Budget 2004	Budget 2005	Budget 2006
OPERATIONS						
General Fund						
2100 Medical Examiner	253,942	261,018	263,581	282,000	289,511	297,897
2945 Leoff I Medical Benefits	-	-	125,439	164,000	215,311	235,948
4010 Microfilming	115,959	96,491	110,584	7,616	-	-
4015 Imaging	-	-	-	20,000	-	-
4017 Law & Justice Strategic Plan	92,276	92,622	15,000	10,000	10,000	10,000
4018 Secure Schools Funding	-	40,500	-	-	-	-
4025 Indigent Burial	15,257	8,833	14,657	15,000	15,000	15,000
4035 County Morgue	65,269	71,182	58,412	43,000	43,535	44,361
4040 Strategic Planning	-	-	-	4,000	4,000	4,000
4050 Domestic Violence	15,000	15,000	21,000	59,500	59,500	59,500
4055 Starling Program	15,000	15,000	15,000	15,000	15,000	15,000
4060 Public Health/ Home Health	9,650	10,000	10,000	10,000	10,000	10,000
4070 Annual State Audit	89,768	97,606	105,106	120,000	120,000	120,000
4075 Leave Pay Out	269,908	100,577	229,017	300,000	300,000	300,000
4085 Employee Recognition	2,766	1,221	1,523	3,000	3,000	3,000
4090 Association Dues	50,162	53,091	55,417	57,455	59,500	61,750
4100 Criminal Justice Data Integr.	35,311	45,477	12,285	30,000	30,000	30,000
4105 Sister County Project	-	359	-	5,000	5,000	5,000
4115 Water Conservancy Board	6,128	3,591	5,273	6,000	6,000	6,000
4120 Civil Service Commission	1,200	1,200	1,200	1,500	-	-
4125 Chamber Business Svc Center	7,500	7,500	7,500	7,500	-	-
4130 Horticultural Inspection	10,187	10,249	10,251	10,440	10,440	10,440
4135 Pest Control	-	-	-	5,000	5,000	5,000
4140 Economic Development	15,000	15,000	15,000	15,000	20,000	20,000
4150 Courthouse Safety	-	-	-	-	260,000	260,000
4160 LEOFF Board	254	353	166	2,000	2,300	2,300
4240 Northwest Regional Council	66,206	67,843	69,097	68,673	79,302	88,300
4250 Emerg Communication-911	622,871	607,502	631,271	612,452	655,868	675,000
4260 Whatcom Creek Incident	7	-	-	-	-	-
4270 Ambulance Services	1,080,272	1,317,938	1,275,357	1,322,970	1,322,970	1,322,970
4290 Air Pollution Control	25,567	25,987	26,489	26,852	27,229	28,500
4300 Animal Control	292,209	295,820	310,412	328,250	334,815	341,511
4440 Volunteer Support	35,000	35,000	35,000	35,000	35,000	35,000
4450 Planning/ Com Dev COG	56,318	48,850	50,234	51,711	53,781	54,600
4451 Transportation Planning COG	-	-	20,500	20,500	-	-
4455 Readiness to Learn	-	-	8,000	8,000	5,000	-
4456 Music & Art	-	-	25,000	15,000	17,000	17,000
4475 Feasibility Study	-	-	-	74,000	-	-
4515 Homeless Shelter/Lydia Place	7,500	7,500	10,000	10,000	10,000	10,000
4520 Boundary Review	7,363	7,693	10,827	10,081	10,081	10,081
4540 Capital Acquisitions	49,593	33,225	31,501	31,756	-	-
4900 Misc Non-Departmental	261,492	197,984	168,061	235,672	1,775,994	2,780,115

continued on next page

Program Summary continued

	Actual 2001	Actual 2002	Actual 2003	Budget 2004	Budget 2005	Budget 2006
121 Low Income Housing Fund	-	-	-	300,000	335,000	541,700
141 WC Convention Center	100,000	131,500	137,999	136,500	161,584	153,584
175 Conservation Futures Fund	35,112	20,036	24,617	27,500	25,000	25,000
332 Public Utilities Imprv Fund	162,283	15,089	325,390	1,198,552	539,023	131,184
503 WC Supplemental Retirement	68,534	158,916	157,929	-	-	-
<i>Total Non-Dept'l Operations</i>	3,940,864	3,917,753	4,394,095	5,706,480	6,870,744	7,729,741
CAPITAL						
General Fund						
4015 Imaging	-	-	-	25,000	-	-
4900 Misc Non-Departmental	-	-	21,121	-	-	-
141 WC Convention Center	-	-	-	14,000	-	-
175 Conservation Futures Fund	100,171	458,978	-	944,350	50,000	50,000
332 Public Utilities Imprv Fund	-	-	78,691	334,600	370,000	-
<i>Total Non-Dept'l Capital</i>	100,171	458,978	99,812	1,317,950	420,000	50,000
DEBT SERVICE						
332 Public Utilities Imprv Fund	-	-	-	500,000	-	-
<i>Total Non-Dept'l Debt Service</i>	-	-	-	500,000	-	-
TRANSFERS						
General Fund						
4010 Microfilming	1,183	-	-	-	-	-
4021 GIS Support	-	-	-	10,000	-	-
4022 Lake Whatcom Management	-	-	-	100,000	100,000	100,000
4100 Criminal Justice Data Integr.	572	-	-	-	-	-
4120 Civil Service Commission	-	-	-	-	24,945	25,456
4490 Marine Resources Support	-	-	-	-	155,000	155,000
4530 Transfers to Other Funds	3,410,755	2,854,416	1,188,786	1,323,213	2,455,591	1,232,600
4900 Misc Non-Departmental	778,000	50,000	120,000	-	-	-
151 Community Development	5,000	5,000	5,000	5,000	5,000	5,000
175 Conservation Futures Fund	-	29,244	-	-	-	-
332 Public Utilities Imprv Fund	-	90,000	-	-	-	-
<i>Total Non-Dept'l Transfers</i>	4,195,510	3,028,660	1,313,786	1,438,213	2,740,536	1,518,056
TOTAL NON-DEPARTMENTAL	8,236,545	7,405,391	5,807,693	8,962,643	10,031,280	9,297,797
<i>Percent change from previous year</i>	20.8%	-10.1%	-21.6%	54.3%	11.9%	-7.3%

2005-2006 Funding Sources

	2005	2006
Autopsy Fee	30,000	30,000
Contribution from Alcoa	124,500	0
General Fund	5,524,438	6,781,173
Sales Tax - Public Utilities Imp.	539,023	131,184
Filing Fees - Low Inc Housing Fund	335,000	541,700
Hotel/Motel Tax-Convention Ctr	161,584	153,584
Property Tax - Conserv Futures	25,000	25,000
Collections Income & Misc Revenues	131,199	67,100
Total Funding	6,870,744	7,729,741

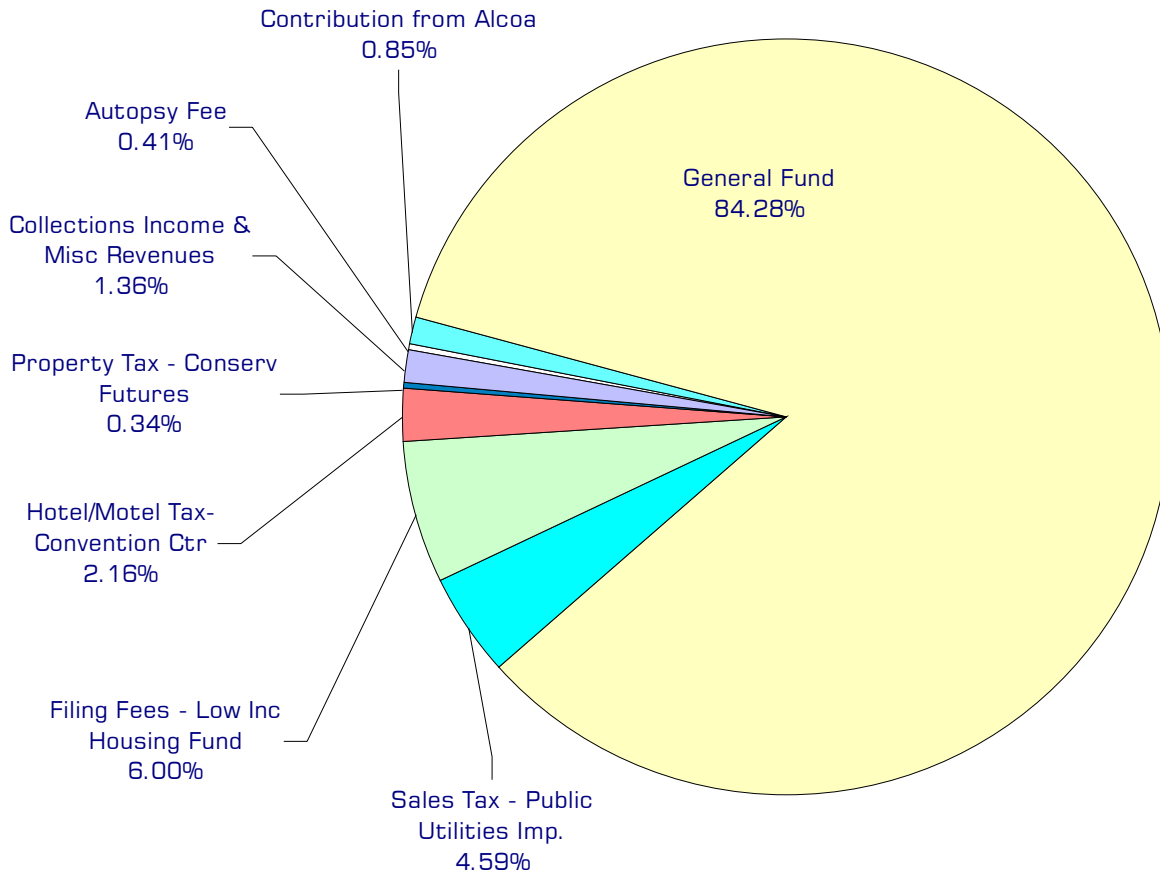

2005-2006 Funding Sources continued

Autopsy Fees

Pursuant to RCW 68.50.104, the county is partially reimbursed by the state for the costs of performing autopsies.

Contributions from Alcoa

Donations from Alcoa to fund various programs.

General Fund

Undedicated General Fund resources.

Sales Tax - Public Utilities Improvement Fund

Pursuant to RCW 82.14.370, the county is authorized to collect .08 percent additional sales tax, which is credited against the state's 6.5% portion. The money is dedicated to public facilities. The chart does not include funding for capital expenditures and loans.

Filing Fees - Low Income Housing Fund

Pursuant to RCW 36.22.178, the Auditor's Office collects an additional \$10 recording fee (per document), which provides funding for local low income housing.

Hotel/Motel Tax - Convention Center

Pursuant to RCW 67.28.210, the county levies an excise tax on hotel, motel or other lodging sales. The revenue collected from this tax is used for the operation of the Bellingham/Whatcom County Visitor/Convention Center and various other activities that promote tourism in Whatcom County.

Property Tax - Conservation Futures

A tax imposed pursuant to RCW 84.34.230, levied at six and one quarter cents per \$1,000 of assessed valuation of real property within Whatcom County. Money collected for the Conservation Futures Fund is used solely to acquire rights and interest in open space land, farm and agricultural land and timber land. The chart does not include funds dedicated to capital expenditures.

Collections Income and Miscellaneous Revenues

Revenues collected as a result of court-related collection activities and various minor revenues.

Expenditures Summary

	Actual 2001	Actual 2002	Actual 2003	Budget 2004	Budget 2005	Budget 2006
GENERAL FUND						
2100 Medical Examiner						
Supplies	-	-	-	5,000	5,000	5,000
Other Services & Charges	253,942	261,018	263,581	277,000	284,511	292,897
<i>Total Medical Examiner</i>	<i>253,942</i>	<i>261,018</i>	<i>263,581</i>	<i>282,000</i>	<i>289,511</i>	<i>297,897</i>
2945 Leoff I Medical Benefits						
Benefits	-	-	123,139	156,710	203,011	223,318
Other Services & Charges			2,300	7,290	12,300	12,630
<i>Total Leoff I Medical Benefits</i>	<i>-</i>	<i>-</i>	<i>125,439</i>	<i>164,000</i>	<i>215,311</i>	<i>235,948</i>
4010 Microfilming						
Salaries	76,763	66,665	75,640	-	-	-
Benefits	27,024	25,271	30,312	-	-	-
Other Services & Charges	12,172	4,555	4,632	7,616	-	-
Operating Transfers	1,183	-	-	-	-	-
<i>Total Microfilming</i>	<i>117,142</i>	<i>96,491</i>	<i>110,584</i>	<i>7,616</i>	<i>-</i>	<i>-</i>
4015 Imaging						
Other Services & Charges	-	-	-	20,000	-	-
Capital Outlay	-	-	-	25,000	-	-
<i>Total Imaging</i>	<i>-</i>	<i>-</i>	<i>-</i>	<i>45,000</i>	<i>-</i>	<i>-</i>
4017 Law & Justice Support						
Other Services & Charges	92,276	92,622	15,000	10,000	10,000	10,000
<i>Total Law/Justice Support</i>	<i>92,276</i>	<i>92,622</i>	<i>15,000</i>	<i>10,000</i>	<i>10,000</i>	<i>10,000</i>
4018 Secure School Funding Project						
Other Services & Charges	-	40,500	-	-	-	-
<i>Total Secure Sch Funding Proj</i>	<i>-</i>	<i>40,500</i>	<i>-</i>	<i>-</i>	<i>-</i>	<i>-</i>
4021 GIS Support						
Operating Transfer Out	-	-	-	10,000	-	-
<i>Total GIS Support</i>	<i>-</i>	<i>-</i>	<i>-</i>	<i>10,000</i>	<i>-</i>	<i>-</i>
4022 Lake Whatcom Management						
Operating Transfer Out	-	-	-	100,000	100,000	100,000
<i>Total Lake Whatcom Mngmt</i>	<i>-</i>	<i>-</i>	<i>-</i>	<i>100,000</i>	<i>100,000</i>	<i>100,000</i>
4025 Indigent Burial						
Other Services & Charges	15,257	8,833	14,657	15,000	15,000	15,000
<i>Total Indigent Burial</i>	<i>15,257</i>	<i>8,833</i>	<i>14,657</i>	<i>15,000</i>	<i>15,000</i>	<i>15,000</i>
4035 County Morgue						
Supplies	3,419	4,469	3,131	-	-	-
Other Services & Charges	61,850	66,713	55,281	43,000	43,535	44,361
<i>Total County Morgue</i>	<i>65,269</i>	<i>71,182</i>	<i>58,412</i>	<i>43,000</i>	<i>43,535</i>	<i>44,361</i>
4040 Strategic Planning						
Other Services & Charges	-	-	-	4,000	4,000	4,000
<i>Total Strategic Planning</i>	<i>-</i>	<i>-</i>	<i>-</i>	<i>4,000</i>	<i>4,000</i>	<i>4,000</i>

continued on next page

Expenditures Summary continued

	Actual 2001	Actual 2002	Actual 2003	Budget 2004	Budget 2005	Budget 2006
4050 Domestic Violence						
Other Services & Charges	15,000	15,000	21,000	59,500	59,500	59,500
<i>Total Domestic Violence</i>	15,000	15,000	21,000	59,500	59,500	59,500
4055 Starling Program						
Other Services & Charges	15,000	15,000	15,000	15,000	15,000	15,000
<i>Total Starling Program</i>	15,000	15,000	15,000	15,000	15,000	15,000
4060 Public Health/ Home Health						
Intergov Services & Charge	9,650	10,000	10,000	10,000	10,000	10,000
<i>Total Public/Home Health</i>	9,650	10,000	10,000	10,000	10,000	10,000
4070 Annual State Audit						
Intergov Services & Charge	89,768	97,606	105,106	120,000	120,000	120,000
<i>Total Annual State Audit</i>	89,768	97,606	105,106	120,000	120,000	120,000
4075 Leave Pay Out						
Salaries & Wages	254,569	97,105	224,166	300,000	300,000	300,000
Benefits	15,339	3,472	4,851	-	-	-
<i>Total Leave Pay Out</i>	269,908	100,577	229,017	300,000	300,000	300,000
4085 Employee Recognition						
Supplies	2,766	1,221	1,523	3,000	3,000	3,000
<i>Total Employee Recognition</i>	2,766	1,221	1,523	3,000	3,000	3,000
4090 Association Dues						
Other Services & Charges	50,162	53,091	55,417	57,455	59,500	61,750
<i>Total Association Dues</i>	50,162	53,091	55,417	57,455	59,500	61,750
4100 Criminal Justice Data Integr.						
Other Services & Charges	35,311	45,477	12,285	30,000	30,000	30,000
Operating Transfers	572	-	-	-	-	-
<i>Total Crim Justice Date Integr</i>	35,883	45,477	12,285	30,000	30,000	30,000
4105 Sister County Project						
Other Services & Charges	-	359	-	5,000	5,000	5,000
<i>Total Sister County Project</i>	-	359	-	5,000	5,000	5,000
4115 Water Conservancy Board						
Other Services & Charges	6,128	3,591	5,273	6,000	6,000	6,000
<i>Total Water Conservancy Board</i>	6,128	3,591	5,273	6,000	6,000	6,000
4120 Civil Service Commission						
Other Services & Charges	1,200	1,200	1,200	1,500	-	-
Operating Transfers	-	-	-	-	24,945	25,456
<i>Total Civil Service Commission</i>	1,200	1,200	1,200	1,500	24,945	25,456
4125 Chamber Business Svc Cntr						
Other Services & Charges	7,500	7,500	7,500	7,500	-	-
<i>Total Chamber Bus. Svc Cntr</i>	7,500	7,500	7,500	7,500	-	-

continued on next page

Expenditures Summary continued

	Actual 2001	Actual 2002	Actual 2003	Budget 2004	Budget 2005	Budget 2006
4130 Horticultural Inspection						
Other Services & Charges	10,187	10,249	10,251	10,440	10,440	10,440
<i>Total Horticultural Inspection</i>	10,187	10,249	10,251	10,440	10,440	10,440
4135 Pest Control						
Other Services & Charges	-	-	-	5,000	5,000	5,000
<i>Total Pest Control</i>	-	-	-	5,000	5,000	5,000
4140 Economic Development						
Other Services & Charges	15,000	15,000	15,000	15,000	20,000	20,000
<i>Total Economic Development</i>	15,000	15,000	15,000	15,000	20,000	20,000
4150 Courthouse Safety						
Other Services & Charges	-	-	-	-	260,000	260,000
<i>Total Courthouse Safety</i>	-	-	-	-	260,000	260,000
4160 LEOFF Board						
Supplies	180	322	90	825	825	825
Other Services & Charges	74	31	76	1,175	1,475	1,475
<i>Total LEOFF Board</i>	254	353	166	2,000	2,300	2,300
4240 Northwest Regional Council						
Intergov Services & Charge	66,206	67,843	69,097	68,673	79,302	88,300
<i>Total NW Regional Council</i>	66,206	67,843	69,097	68,673	79,302	88,300
4250 Emergency Communication - 911						
Intergov Services & Charge	622,871	607,502	631,271	612,452	655,868	675,000
<i>Total Emerg Communication</i>	622,871	607,502	631,271	612,452	655,868	675,000
4260 Whatcom Creek Incident						
Salary & Wages	7	-	-	-	-	-
<i>Total Whatcom Creek Incident</i>	7	-	-	-	-	-
4270 Ambulance Services						
Intergov Services & Charge	1,080,272	1,317,938	1,275,357	1,322,970	1,322,970	1,322,970
<i>Total Ambulance Services</i>	1,080,272	1,317,938	1,275,357	1,322,970	1,322,970	1,322,970
4290 Air Pollution Control						
Intergov Services & Charge	25,567	25,987	26,489	26,852	27,229	28,500
<i>Total Air Pollution Control</i>	25,567	25,987	26,489	26,852	27,229	28,500
4300 Animal Control						
Other Services & Charges	292,209	295,820	310,412	328,250	334,815	341,511
<i>Total Animal Control</i>	292,209	295,820	310,412	328,250	334,815	341,511
4440 Whatcom Volunteer Center						
Other Services & Charges	35,000	35,000	35,000	35,000	35,000	35,000
<i>Total Whatcom Volunteer Center</i>	35,000	35,000	35,000	35,000	35,000	35,000
4450 Council of Governments						
Intergov Services & Charge	56,318	48,850	50,234	51,711	53,781	54,600
<i>Total Council of Governments</i>	56,318	48,850	50,234	51,711	53,781	54,600

continued on next page

Expenditures Summary continued

	Actual 2001	Actual 2002	Actual 2003	Budget 2004	Budget 2005	Budget 2006
4451 Transportation Planning COG						
Other Services & Charges	-	-	20,500	20,500	-	-
<i>Total Transp Planning COG</i>	-	-	20,500	20,500	-	-
4455 Readiness to Learn						
Other Services & Charges	-	-	8,000	8,000	5,000	-
<i>Total Readiness to Learn</i>	-	-	8,000	8,000	5,000	-
4456 Music & Art						
Other Services & Charges	-	-	25,000	15,000	17,000	17,000
<i>Total Music & Art</i>	-	-	25,000	15,000	17,000	17,000
4475 Feasibility Study						
Other Services & Charges	-	-	-	74,000	-	-
<i>Total Feasibility Study</i>	-	-	-	74,000	-	-
4490 Marine Resources Support						
Operating Transfer Out	-	-	-	-	155,000	155,000
<i>Total Marine Resources Support</i>	-	-	-	-	155,000	155,000
4515 Homeless Shelter/Lydia Place						
Other Services & Charges	7,500	7,500	10,000	10,000	10,000	10,000
<i>Total Homeless Shelter/Lydia Pl</i>	7,500	7,500	10,000	10,000	10,000	10,000
4520 Boundary Review Board						
Supplies	75	13	46	-	-	-
Other Services & Charges	7,288	7,680	10,781	10,081	10,081	10,081
<i>Total Boundary Review Board</i>	7,363	7,693	10,827	10,081	10,081	10,081
4530 Transfer to Other Funds						
Operating Transfers	3,410,755	2,854,416	1,188,786	1,323,213	2,455,591	1,232,600
<i>Total Transfer to Other Funds</i>	3,410,755	2,854,416	1,188,786	1,323,213	2,455,591	1,232,600
4540 Capital Acquisitions						
Supplies	1,814	7	-	-	-	-
Other Services & Charges	47,779	33,218	31,501	31,756	-	-
<i>Total Capital Acquisitions</i>	49,593	33,225	31,501	31,756	-	-
4900 Miscellaneous Non-Departmental						
Salaries & Wages	-	-	-	-	1,517,744	2,548,872
Benefits	-	-	-	-	24,369	13,473
Supplies	-	-	-	-	26,000	1,000
Other Services & Charges	261,492	197,984	168,061	235,672	207,881	216,770
Capital Outlay	-	-	21,121	-	-	-
Operating Transfers	778,000	50,000	120,000	-	-	-
<i>Total Misc. Non-Departmental</i>	1,039,492	247,984	309,182	235,672	1,775,994	2,780,115
TOTAL GENERAL FUND	7,765,445	6,496,628	5,078,067	5,502,141	8,545,673	8,391,329
<i>Percent Change From Previous Year</i>	43.0%	-16.3%	-21.8%	8.4%	55.3%	-1.8%

continued on next page

Expenditures Summary continued

	Actual 2001	Actual 2002	Actual 2003	Budget 2004	Budget 2005	Budget 2006
121 LOW INCOME HOUSING FUND						
Other Services & Charges	-	-	-	300,000	335,000	541,700
<i>Total Low Income Housing Fund</i>	-	-	-	300,000	335,000	541,700
<i>Percent Change From Previous Year</i>	0.0%	0.0%	0.0%	0.0%	11.7%	61.7%
141 WC CONVENTION CENTER FUND						
Supplies	-	-	3,999	-	1,000	1,000
Other Services & Charges	100,000	131,500	134,000	136,500	160,584	152,584
Capital Outlay	-	-	-	14,000	-	-
<i>Total Convention Center</i>	100,000	131,500	137,999	150,500	161,584	153,584
<i>Percent Change From Previous Year</i>	-7.6%	31.5%	4.9%	9.1%	7.4%	-5.0%
151 COMMUNITY DEVELOPMENT FUND						
Operating Transfers	5,000	5,000	5,000	5,000	5,000	5,000
<i>Total Community Develop Fund</i>	5,000	5,000	5,000	5,000	5,000	5,000
<i>Percent Change From Previous Year</i>	0.0%	0.0%	0.0%	0.0%	0.0%	0.0%
175 CONSERVATIONS FUTURE FUND						
Other Services & Charges	35,112	20,036	24,617	27,500	25,000	25,000
Capital Outlay	100,171	458,978	-	944,350	50,000	50,000
Operating Transfers	-	29,244	-	-	-	-
<i>Total Conservation Futures Fund</i>	135,283	508,258	24,617	971,850	75,000	75,000
<i>Percent Change From Previous Year</i>	-89.4%	275.7%	-95.2%	3847.9%	-92.3%	0.0%
332 PUBLIC UTILITIES IMPRV FUND						
Salaries & Wages	-	-	-	56,225	72,816	75,684
Benefits	-	-	-	14,311	27,207	30,500
Supplies	-	-	-	5,500	-	-
Other Services & Charges	162,283	15,089	325,390	1,122,516	439,000	25,000
Operating Transfers	-	90,000	-	-	-	-
Capital Outlay	-	-	78,691	334,600	370,000	-
Debt Service	-	-	-	500,000	-	-
<i>Total Public Utilities Imprv Fund</i>	162,283	105,089	404,081	2,033,152	909,023	131,184
<i>Percent Change From Previous Year</i>	0.0%	-35.2%	284.5%	403.2%	-55.3%	-85.6%
503 WHATCOM COUNTY SUPPLEMENTAL RETIREMENT FUND						
Benefits	68,534	158,916	157,929	-	-	-
<i>Total WC Suppl Retirement Fund</i>	68,534	158,916	157,929	-	-	-
<i>Percent Change from Previous Year</i>	0.0%	131.9%	-0.6%	-100.0%	0.0%	0.0%
TOTAL NON-DEPARTMENTAL	8,236,545	7,405,391	5,807,693	8,962,643	10,031,280	9,297,797
<i>Percent Change From Previous Year</i>	20.8%	-10.1%	-21.6%	54.3%	11.9%	-7.3%

Services

Annual State Audit

As mandated by state law, Whatcom County obtains an annual audit for compliance with governmental accounting standards and finance-related legal requirements of federal awards. Services are provided by the State Auditor's Office.

Air Pollution Control

The Northwest Air Pollution Authority is responsible for prevention, abatement and control of air pollution within its jurisdiction. RCW 70.94 authorizes the Authority to levy assessments on a per capita basis on all jurisdictions within its boundaries.

Ambulance Services

Whatcom County contracts with the City of Bellingham to provide ambulance services to the residents of unincorporated Whatcom County.

Animal Control

Animal housing and control services, and enforcement of related ordinances is provided by contract for unincorporated areas of Whatcom County.

Association Dues

Dues paid to participate in government associations, i.e., WSAC, WACO, CEA and NACO.

Boundary Review Board

All corporate boundary changes such as incorporations, annexations or extension of services proposed by cities or special purpose districts are reviewed by the board which considers the effects of such actions on area residents. The payment of a \$200 fee per action allows affected jurisdictions, such as Whatcom County, to request a public hearing before the Board so that agreement on differences may be reached prior to the action of the Board being finalized.

Civil Service Commission

Civil service commission duties as mandated by RCW 41.14.050. The Human Resources Division of A.S. coordinates this activity.

Council of Governments

The Whatcom County Council of Governments is an intergovernmental agency supported by the jurisdictions it includes. It was formed to coordinate planning and community development within the county.

County Morgue

Lease, utilities, and operating supplies for the morgue, for use by the medical examiner to perform autopsy services.

Criminal Justice Data Integration

Support to departments to assist in the development of a multi-jurisdictional data system.

Services continued

Courthouse Safety

Develop and implement a coordinated plan to improve the safety and security of all users of the Whatcom County Courthouse.

Domestic Violence Commission

Develop and implement a coordinated comprehensive domestic violence plan, increase community awareness, and service as an advisory board.

Domestic Violence/Womencare Shelter

Whatcom County provides assistance to Womencare Shelter.

Economic Development

The purpose of the Bellingham Whatcom Economic Development Council (EDC) is to encourage new business investments in Whatcom County. Whatcom County contracts with EDC to provide this service.

Emergency Communication - 911

A county-wide emergency communication system is operated by the City of Bellingham with the support of all jurisdictions within the county. The county pays proportionately for the services provided to residents of the unincorporated area.

Employee Recognition

Provide for annual employee recognition; contributions received to cover expense.

Homeless Shelter/Lydia Place

Whatcom County provides assistance to Lydia Place, offering transitional housing and support services to homeless women and children.

Horticulture Inspection

The county contracts with the State Department of Agriculture for horticulture inspection services in support of the agriculture industry in Whatcom County.

Indigent Burial

Provide payment of burial costs for people who die without resources to cover this expense.

Lake Whatcom Management

Administrative support and coordination of the Lake Whatcom Management Program.

Law & Justice Support

Through a contract with Northwest Regional Council, provide clerical support to Whatcom County Law and Justice Council.

Leave Pay Out

Provide fund bank for leave pay out (sick leave and vacation) for retiring employees.

LEOFF Board

RCW 41.26.110 requires a board to act on all claims for disability to be paid by the Law Enforcement Officers' and Fire Fighters' (LEOFF I) retirement system plan.

Services continued

LEOFF I Medical Benefits

RCW 41.25.150 requires counties to provide complete medical benefits for members (active and retired) of the Law Enforcement Officers and Firefighters (LEOFF I) retirement system plan.

Marine Resources Support

Preservation and restoration of marine habitat in Whatcom County and shellfish protection.

Medical Examiner

Contract for services to provide medical examiner services to the county.

Misc Non-Departmental

Provides wage reserves for contract settlements and Executive Contingency Fund for emergency funding at discretion of County Executive.

Music and Art - Mt. Baker Theatre

Funding to Mt. Baker Theatre to support educational program for youth outreach arts program.

Music and Art - Whatcom Symphony Orchestra

Whatcom County contracts with the Whatcom Symphony Orchestra to enhance the cultural and artistic life of our community, and offer people of all ages and economic backgrounds the opportunity to experience live symphonic music.

Northwest Regional Council

The Northwest Regional Council (NWRC) is an intergovernmental agency which provides certain specific law enforcement-related support regionwide (i.e. radio repeater sites, etc.), and services for the aging. Costs are shared by four counties.

Pest & Disease Board

Whatcom County Pest & Disease Board works to prevent the spread of new pests and diseases into Whatcom County through education and immediate measures.

Public Health/Home Health

Whatcom County has an agreement with the NWRC to contract with Whatcom County Council on Aging (subcontracting with Visiting Nurse Personal Services) to provide well adult services.

Readiness to Learn

Support to the Bellingham School District for the Readiness to Learn Program.

Strategic Planning

Provide for strategic planning by executive and legislative branches.

Starling Program

Whatcom County Agriculture Preservation Committee provides advocacy for farmers and rural residents. This project assists in funding the starling program.

Sister County Project

Develop sister county relationships with Ganghwa County in Korea and Da Shi Qiao County in China.

Transfers to other funds

Provides funding for remodel, repair, and maintenance projects for county facilities, Weed Control Positions in the Road Fund, Emergency Management Services, replacement of computer equipment in departments.

Water Conservancy Board

Provides staff support through contract with NWRC for Water Conservancy Board.

Whatcom Volunteer Center

Whatcom Volunteer Center provides volunteer services to a number of county departments as well as community non-profits, schools, other government and healthcare-related worksites.

Convention Center Fund Services**Baker Cookie Triathlon**

Funds are used to promote overnight stays in Whatcom County in conjunction with the Baker Cookie Triathlon.

Bellingham Festival of Music

Funds are used to attract overnight visitors to Whatcom County to experience live music performances at the highest artistic level by nationally and internationally renowned musicians in a concentrated festival format.

Bellingham Whatcom County Convention and Visitors Bureau

Funds are used to promote tourism in Whatcom County.

Bellingham/Whatcom Chamber of Commerce and Industry

Funds are used to promote overnight stays in Whatcom County in conjunction with the Ski to Sea Race.

Glacier Restroom

Funds are used to provide for maintenance and upkeep for the Glacier restrooms.

Mt. Baker Foothills Chamber of Commerce

Funds are used to promote tourism in eastern Whatcom County.

Extension

In cooperation with Whatcom County, this department is an extension of Washington State University. It provides information and education in the following areas (as well as others): agriculture and natural resources, food safety, community resources, pesticides, farm building and facilities plans, parenting, budgeting and money management, bee safety, nutrition and home horticulture.

FTE's for this department

Year	2001	2002	2003	*2004	*2005	*2006
FTE	3.79	2.79	2.79	2.52	2.52	2.52

**budget*

The chart below shows the organizational structure for 2005 only.

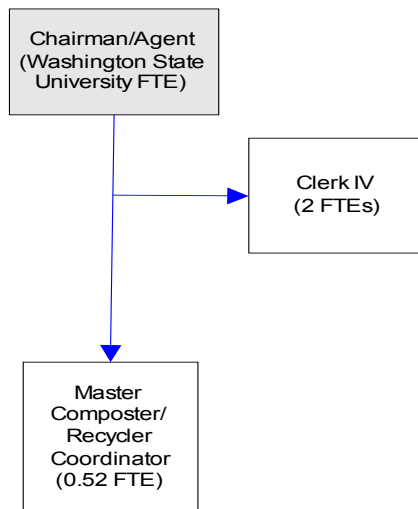

Mission & Objectives

Mission

Extension's job is education. Extension is a unique partnership of federal, state and county governments. Extension transmits practical information produced by research centers and Land Grant universities to the public. Extension's aim is to help local people identify and solve problems. Extension's mission is better agriculture, better families, better communities and in the aggregate, a better world.

Objectives

- Build the capacity of individuals, organizations, businesses and communities, empowering them to find solutions for local issues and to improve their quality of life.
- Maintain relevance to the people of the community by being highly accessible, addressing critical issues, focusing on prevention, maintaining a holistic approach and centering attention on the learner.
- Provide information to farmers that will help them strengthen agriculture through efficiencies in marketing, distribution and production, assuring an abundant and safe supply of food and fiber for American consumers and for export.
- Enhance the ability of individuals and groups in making decisions for wise use and management of the community's natural, renewable, and nonrenewable resources, while assuring a protected environment for an improved quality of life for all citizens.
- Aid in strengthening the institutions of home and family and the development of individual life skills, attitudes, and values among adults and youth; these contribute to a self-directing, productive and harmonious society.
- Low income adults and youth who participate in Food \$ense programs will improve dietary quality and practice improved food resource management.
- Food \$ense program will develop a minimum of 2 new program partners in each of the next 2 years.
- Member enrollment in Traditional 4-H Clubs in 2003-2004 was 994 members. Goal is to expand membership by 1% during the 2004-2005 4-H year to 1000 members.
- Member enrollment in Special Interest 4-H Programs for 2003-2004 was 2775. Goal is to expand membership by 2% during the 2004-2005 4-H year to 2825.
- Whatcom County dairy and other commodity farmers will acquire knowledge and skills about opportunities in value added products to enhance farm profitability.
- Economic viability of anaerobic digesters on dairy farms will be enhanced by the development of ancillary revenue streams from value added digester by-products. This will be facilitated by Extension through relevant research and development and education.
- Local land managers will adopt new technologies to monitor and manage local water resources.

Objectives continued

- With capital funding assistance from WSU, a Whatcom County Dairy farmer will construct and operate an anaerobic digester and provide access to Extension for research and demonstration purposes.
- Offer no less than 25 educational classes to help county residents on compost/recycling issues.
- Partner with 2 new organizations to help facilitate education for county recycling and composting efforts.

Expenditure Trends

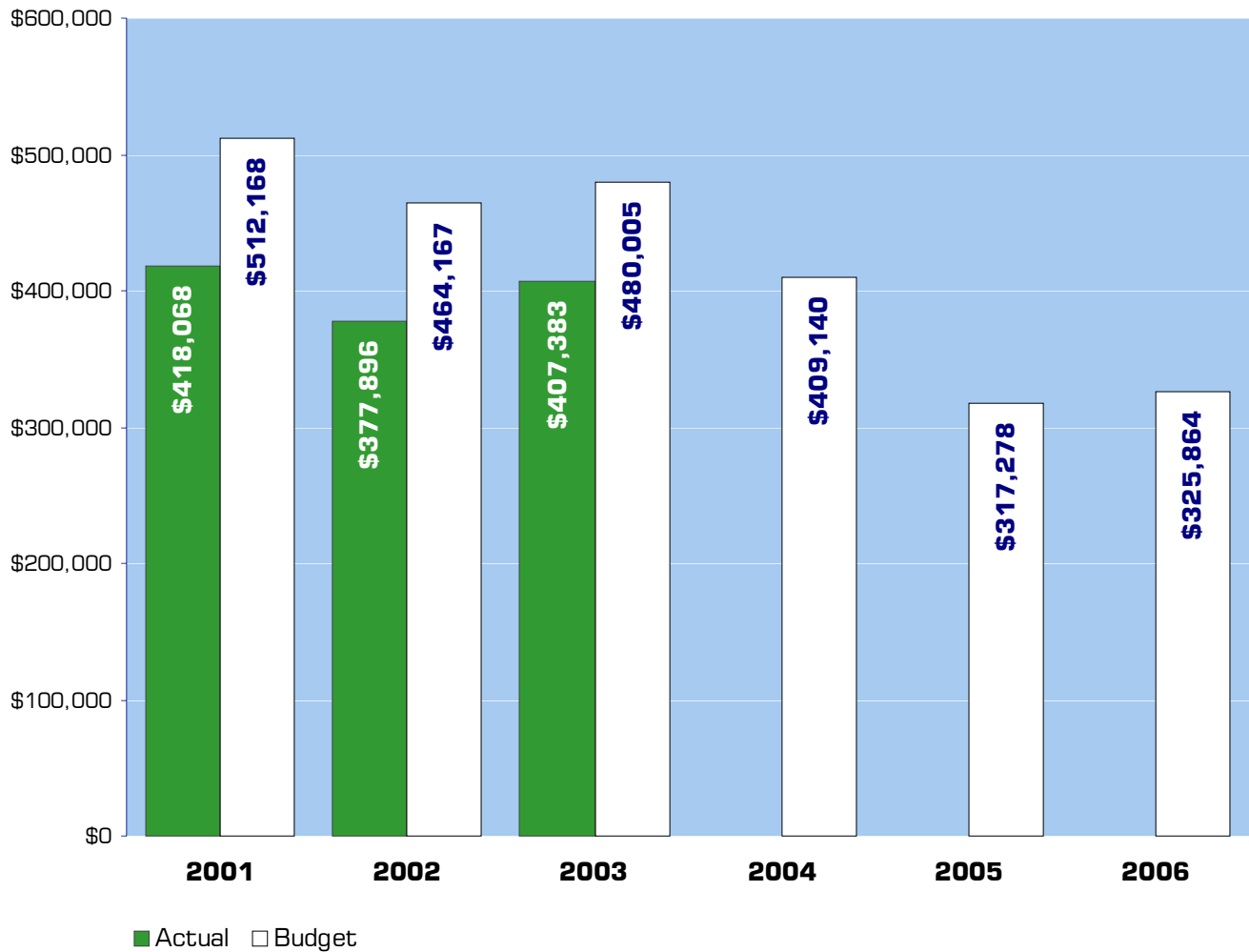

NOTE: Capital expenditures and interfund operating transfers are not shown to more accurately reflect ongoing operational costs.

2005-2006 Budget by Program

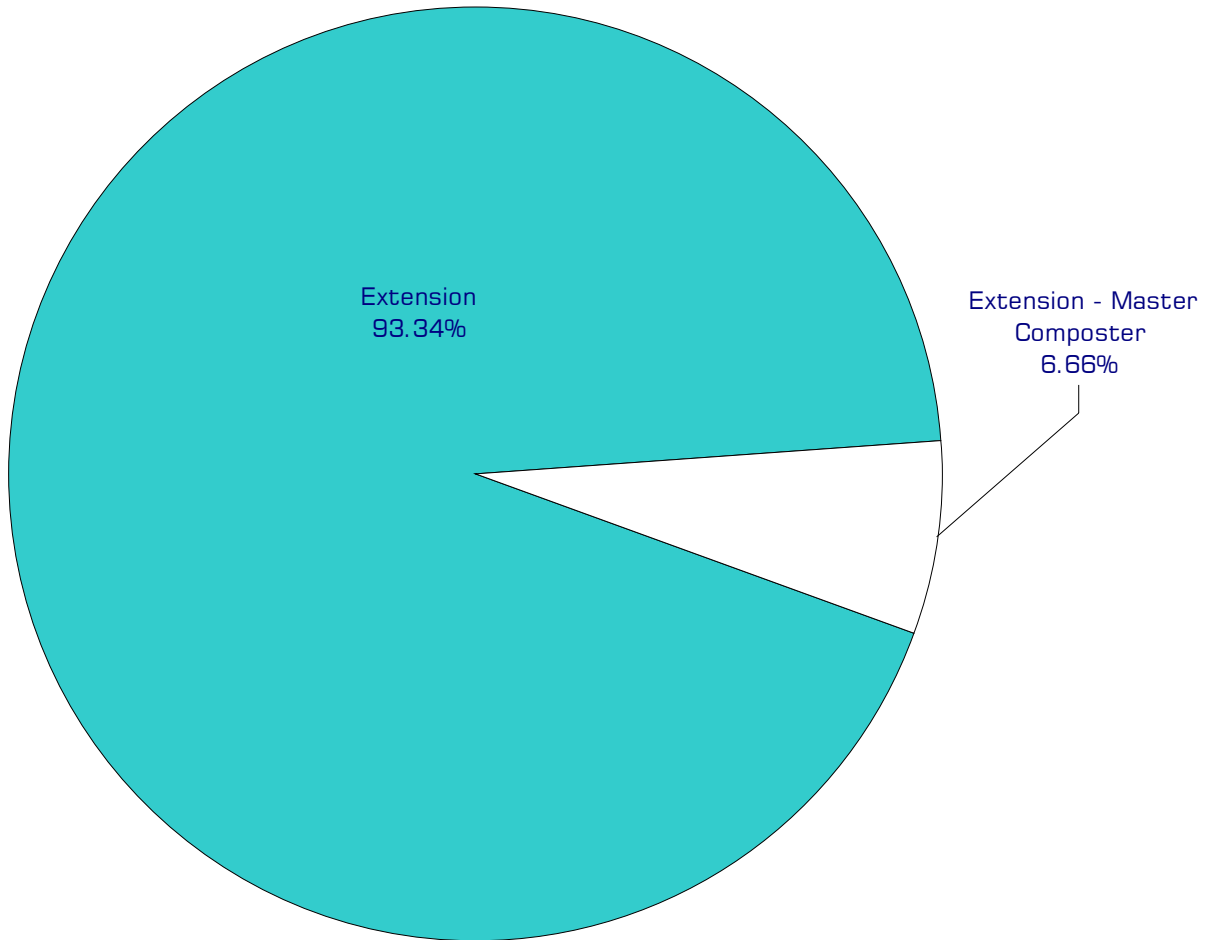

NOTE: Capital expenditures and interfund operating and residual equity transfers are not shown to more accurately reflect ongoing operational costs.

Program Summary

	Actual 2001	Actual 2002	Actual 2003	Budget 2004	Budget 2005	Budget 2006
OPERATIONS						
General Fund						
2000 Extension	209,424	211,421	218,554	237,996	296,158	304,457
2001 Ext-Master Composter	20,609	20,325	20,215	20,844	21,120	21,407
2002 Ext-Watershed Ed	188,035	146,150	168,614	150,300	-	-
<i>Total Extension Operations</i>	418,068	377,896	407,383	409,140	317,278	325,864
CAPITAL						
General Fund						
2000 Extension	-	2,566	-	-	-	-
<i>Total Extension Capital</i>	-	2,566	-	-	-	-
TRANSFERS						
General Fund						
2000 Extension	806	-	-	-	-	-
2001 Extension-Master Composter	191	-	-	-	-	-
2002 Extension-Watershed Education	620	-	-	-	-	-
<i>Total Extension Transfers</i>	1,617	-	-	-	-	-
TOTAL EXTENSION	419,685	380,462	407,383	409,140	317,278	325,864
<i>Percent Change from Previous Year</i>	9.5%	-9.3%	7.1%	0.4%	-22.5%	2.7%

2005-2006 Funding Sources

	2005	2006
Operating Trans - Solid Waste	20,000	20,000
General Fund	297,278	305,864
Total Funding	317,278	325,864

Operating Transfer - Solid Waste

Operating transfer from the Solid Waste Fund to support the Master Composter program.

General Fund

Undedicated General Fund resources.

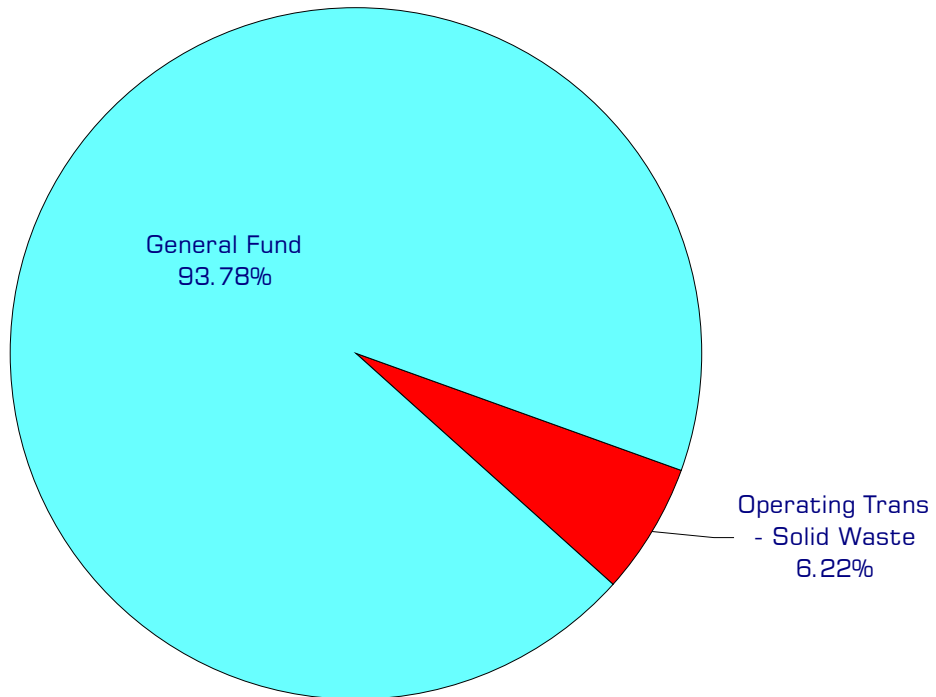

Performance / Activity Measures

	Actual 2001	Actual 2002	Actual 2003	Projected 2004	Projected 2005	Projected 2006
<i>4-H Program</i>						
4-H clubs	76	78	90	90	95	100
Adult Volunteer Leaders - Clubs	206	220	242	216	225	230
Members - Club	842	926	1,005	994	1,000	1,025
Adult Volunteer Leaders - Challenge	61	57	46	38	43	48
Members - Special Interest	1,430	410	350	425	450	475
Members - School Enrichment	1,117	1,216	2,325	2,350	2,375	2,400
<i>Food Sense Program</i>						
Enrollment - Adult Participants				41	80	100
Enrollment - Youth Participants				212	455	546
Contacts (classes, demos, etc.)				1,325	3,060	3,676
<i>Internet Web Access</i>						
Average number of page views/month	18,000	26,000	40,000	52,000	55,000	59,000
<i>Master Composter Recycler</i>						
Volunteer hours	680	490	492	525	550	575
Contacts (phone, classes, events & demo site)	3,554	3,782	4,516	4,500	4,700	4,800
<i>Master Food Preserver & Safety Advisor Program</i>						
Volunteers	30	25	32	40	30	30
Contacts	2,448	1,600	1,800	2,000	1,200	1,200
Volunteer Hours	1,135	1,100	1,200	1,300	900	900
<i>Master Gardener Program</i>						
Trainees	45	43	38	37	40	40
Veterans	243	250	141	180	220	250
Contacts	6,050	6,100	7,800	8,500	9,000	9,500
Volunteer Hours	6,150	6,300	7,050	8,000	8,200	8,400
<i>Strengthening Families Program</i>						
Enrollment - Adults				25	25	30
Enrollment - Youth				30	30	35
Contacts (classes, demos, etc.)				385	385	455

Expenditures Summary

	Actual 2001	Actual 2002	Actual 2003	Budget 2004	Budget 2005	Budget 2006
GENERAL FUND						
2000 Extension						
Salaries & Wages	71,168	69,421	76,408	77,411	78,719	80,069
Benefits	18,951	19,012	21,531	23,555	26,835	29,866
Supplies	9,941	8,600	7,413	4,800	5,450	5,450
Other Services & Charges	109,364	114,388	113,202	132,230	185,154	189,072
Capital Outlay	-	2,566	-	-	-	-
Operating Transfers	806	-	-	-	-	-
<i>Total Extension</i>	<i>210,230</i>	<i>213,987</i>	<i>218,554</i>	<i>237,996</i>	<i>296,158</i>	<i>304,457</i>
<i>Percent Change from Previous Year</i>	<i>0.5%</i>	<i>1.8%</i>	<i>2.1%</i>	<i>8.9%</i>	<i>24.4%</i>	<i>2.8%</i>
2001 Master Composter						
Salaries & Wages	14,618	14,618	14,591	15,207	15,207	15,207
Benefits	2,095	1,880	1,869	1,807	2,083	2,370
Supplies	1,043	1,447	1,739	1,410	1,400	1,400
Other Services & Charges	2,853	2,380	2,016	2,420	2,430	2,430
Operating Transfers	191	-	-	-	-	-
<i>Total Master Composter</i>	<i>20,800</i>	<i>20,325</i>	<i>20,215</i>	<i>20,844</i>	<i>21,120</i>	<i>21,407</i>
<i>Percent Change from Previous Year</i>	<i>1.8%</i>	<i>-2.3%</i>	<i>-0.5%</i>	<i>3.1%</i>	<i>1.3%</i>	<i>1.4%</i>
2002 Watershed Education						
Salaries & Wages	49,303	5,465	10,575	-	-	-
Benefits	11,656	1,068	1,306	-	-	-
Supplies	7,975	5,242	2,464	8,000	-	-
Other Services & Charges	119,101	134,375	154,269	142,300	-	-
Operating Transfers	620	-	-	-	-	-
<i>Total Watershed Education</i>	<i>188,655</i>	<i>146,150</i>	<i>168,614</i>	<i>150,300</i>	<i>-</i>	<i>-</i>
<i>Percent Change from Previous Year</i>	<i>22.7%</i>	<i>-22.5%</i>	<i>15.4%</i>	<i>-10.9%</i>	<i>-100.0%</i>	<i>0.0%</i>
TOTAL EXTENSION	419,685	380,462	407,383	409,140	317,278	325,864
<i>Percent Change from Previous Year</i>	<i>9.5%</i>	<i>-9.3%</i>	<i>7.1%</i>	<i>0.4%</i>	<i>-22.5%</i>	<i>2.7%</i>

Services

4-H/ Youth Development

4-H/Youth Development programs apply research-based methods to develop healthy youth and families in our community.

Ag & Natural Resources - Agriculture

Provides educational and technical assistance to growers of all economic agricultural commodities produced in the county. This assistance includes pest, disease, and cultural problem diagnosis and control recommendations.

Ag & Natural Resources - Environment

Provides factual information and community capacity building to appreciate, protect, and conserve our natural resources through local efforts.

Ag & Natural Resources - Integrated Pest Management

Develop, produce and conduct research and educational efforts that further develop the attitudes, knowledge and skills necessary for the acceptance and adoption of Integrated Pest Management (IPM) practices in Whatcom County.

Family Living Education

Helps parents, families and individuals acquire knowledge and learn life skills to become more responsible and resourceful in today's changing world.

Health Department

The Health Department provides a variety of services to the public: restaurant permits and inspections, food worker health permits, investigation of food-borne illness, solid waste and sewage permits, water quality reviews, animal-to-human disease investigations; communicable disease screening, treatment, investigation, immunizations; vital records (birth and death certificates, etc.); personal health services, services to the developmentally disabled and their families; mental health treatment coordination; chemical dependency treatment coordination and substance abuse prevention.

FTE's for this department

Year	2001	2002	2003	*2004	*2005	*2006	<i>*budget</i>
FTE	83.85	82.50	80.10	80.10	80.50	80.50	

The chart below shows the organizational structure for 2005 only.

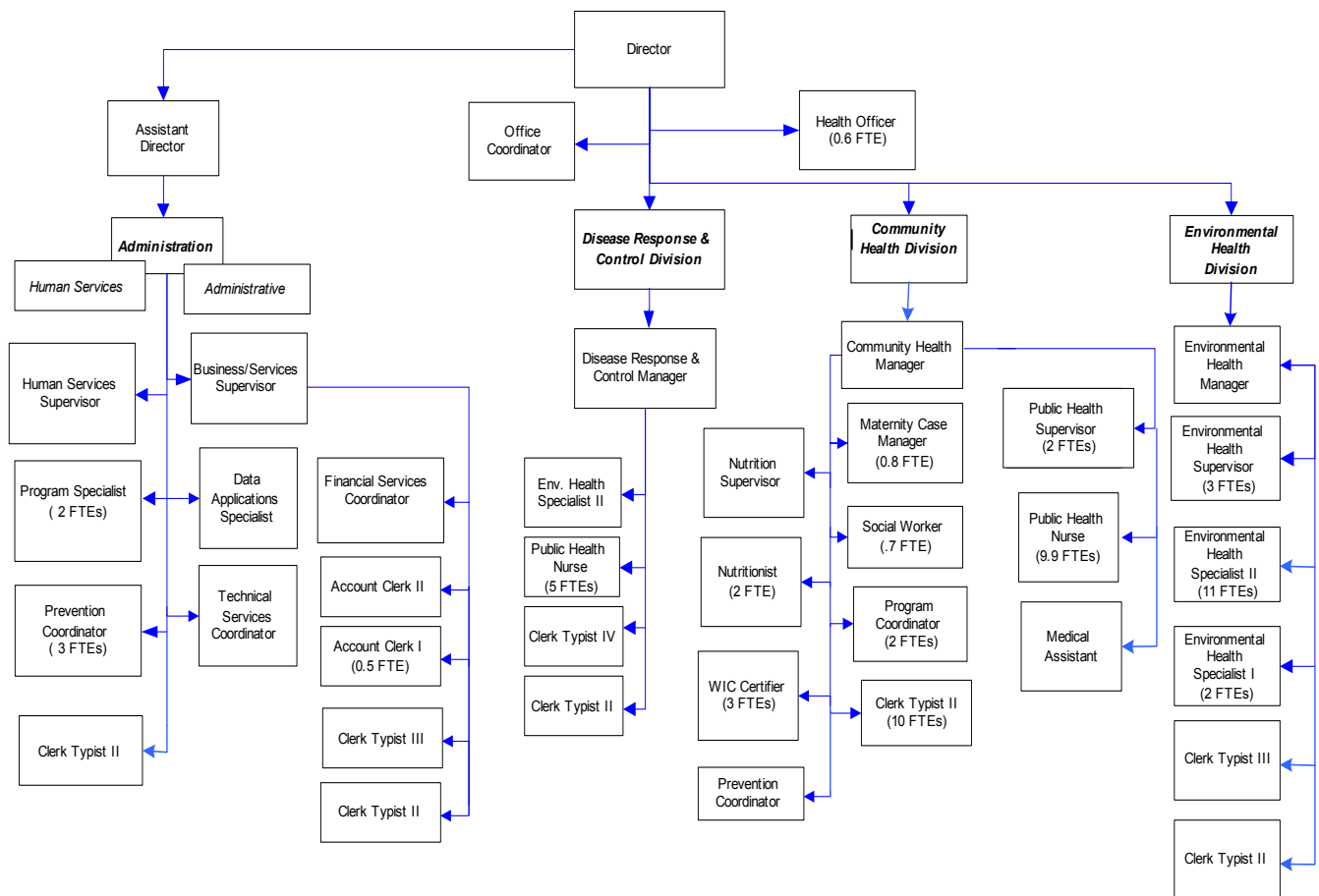

Mission & Objectives

Mission

Preserve and enhance the health and quality of life in Whatcom County.

Community Health

Work with individuals, families and communities to promote wellness, prevent disease and injury, identify and resolve health problems and to ensure access to services as defined by the Standards for Public Health in Washington State.

Environmental Health

Minimize the public's exposure to environmental hazards, such as harmful chemicals and biological agents.

Human Services

Be responsive to the needs of Whatcom County citizens by ensuring quality mental health, substance abuse, and developmental disability services. Support innovative quality-driven community prevention programs for all residents.

Objectives

Community Health

- Implement the state Public Health Issue Management System (PHIMS) database system locally to allow improved analysis of disease outbreaks, direct communication with other health partners and access to other county and statewide disease information.
- Improve notifiable condition reporting by regular communication with and increased education outreach to physician offices.
- Expand emergency planning efforts to involve other health and emergency response partners in system response planning.
- Prepare public health messages related to

probable or possible emergency situations.

- Field test the mass vaccination/medication delivery plan.
- Conduct a social marketing campaign to increase immunization rates of children under age 6.
- Analyze maternal and child home visit outcomes as part of program evaluation.
- Connect with the WSDOH Secures system to ensure secure electronic transmission of health information.
- Conduct five car seat clinics to assess infant and child car seats for safety.

Environmental Health

- By December 31, 2005, 50% of the Environmental Health field staff will be using field-based remote computing for routine inspections and investigations. The computer-based data management system for the environmental health work will be enhanced to support the field.
- As of June 30, 2005, workers in food service establishments will be able to obtain their required food handlers permits during all hours of Health Department operation using a computerized training and testing system.
- By September 2005, new regulations for design, disposal, and operation & maintenance requirements for septic systems will be drafted and presented to the Health Board for adoption.
- By June 30, 2005, local regulations for Health Department response to clandestine drug labs will be drafted and presented to the Health Board for adoption.

Mission & Objectives continued

- By December 31, 2005, new Environmental Health policies, procedures, and protocols will be established and adopted designed to more effectively coordinate with Planning and Development Services and to streamline the land development process.
- 100% of newly discovered clandestine drug labs in residential dwellings will be evaluated for hazards and posted until effective cleanup is completed.
- Within 48 hours of a request for final inspection of a septic system installation, 95% of the inspections will be completed.
- 100% of complaints received by the Environmental Health Division will have initial investigations started within 72 working hours.
- 75 % of complaint investigations will be closed within 3 months of initial investigation or referred for legal action.
- Educate local businesses/employers about the dangers of second hand smoke, and benefits of a smoke-free workplace.
- Develop co-located triage services consisting of mental health crisis' respite and detoxification services to provide cost effective access to behavioral health crisis services.
- Collaborate with school districts to increase preparedness for employment upon graduation for developmentally disabled clients and to increase participation in birth to three early intervention services.

Human Services

- Ensure individuals with developmental disabilities who receive county funded day program services are gainfully employed or have an employment plan.
- Implement the 2060 housing program to provide housing assistance to very low-income persons, and to support operating costs of emergency shelters.
- Establish appropriate outcome measures for substance abuse treatment and support services to determine effectiveness of programs.
- Collaborate with local school districts to establish a diversion program for youth caught smoking on school campuses.

Expenditure Trends

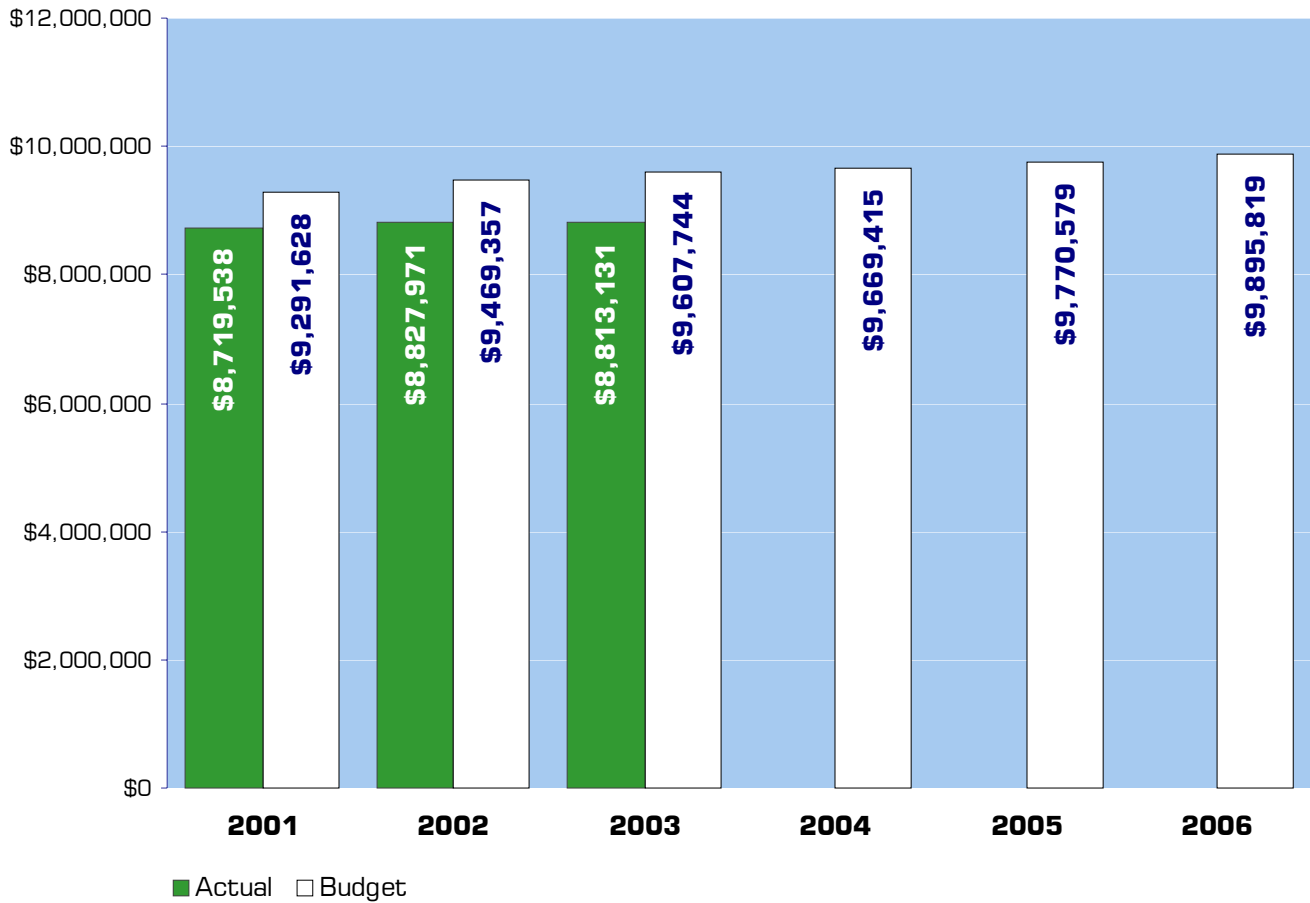

NOTE: Capital expenditures and interfund operating transfers are not shown to more accurately reflect ongoing operational costs.

2005-2006 Budget by Program

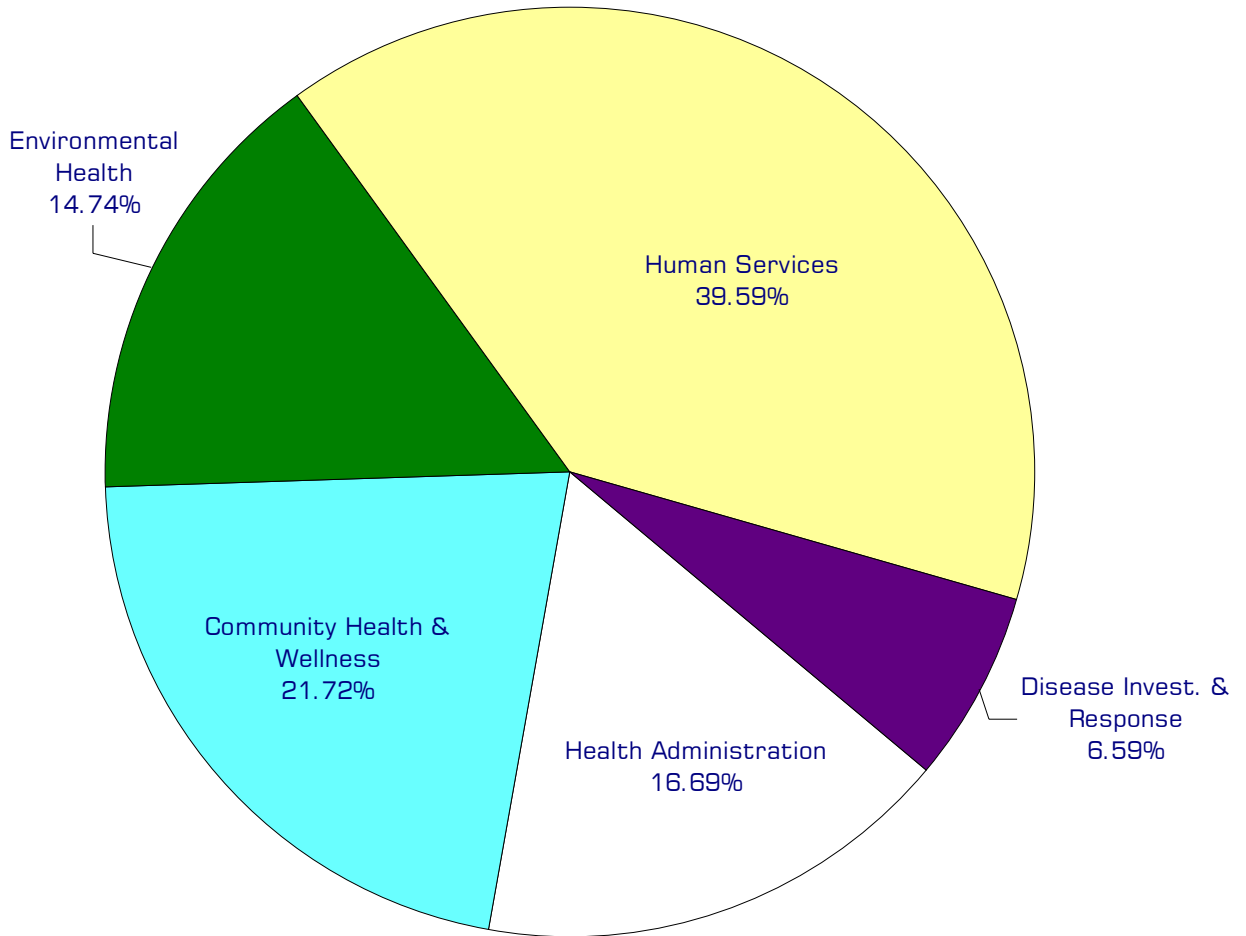

NOTE: Capital expenditures and interfund operating and residual equity transfers are not shown to more accurately reflect ongoing operational costs.

Program Summary

	Actual 2001	Actual 2002	Actual 2003	Budget 2004	Budget 2005	Budget 2006
OPERATIONS						
General Fund						
Health Administration	1,643,222	1,881,077	1,860,954	1,841,065	1,622,458	1,660,375
Community Health & Wellness	2,045,710	1,998,660	2,007,290	1,966,346	2,101,251	2,170,749
Environmental Health	1,267,550	1,202,706	1,176,888	1,347,965	1,486,943	1,541,750
Human Services	3,409,806	3,327,552	3,204,869	3,921,836	3,921,855	3,864,024
Disease Invest. & Response	353,250	417,976	563,130	592,203	638,072	658,921
<i>Total Health Operations</i>	8,719,538	8,827,971	8,813,131	9,669,415	9,770,579	9,895,819
CAPITAL						
General Fund						
Health Administration	28,954	8,643	7,810	89,800	-	-
Community Health & Wellness	11,466	1,132	-	3,000	-	-
Environmental Health	-	-	-	9,000	1,000	1,000
Human Services	-	1,575	1,652	-	-	-
Disease Invest. & Response	-	-	6,709	-	-	-
<i>Total Health Capital</i>	40,420	11,350	16,171	101,800	1,000	1,000
TRANSFERS						
General Fund						
Health Administration	8,643	-	-	1,200	1,707	1,274
Community Health & Wellness	20,631	-	-	-	-	-
Environmental Health	9,725	-	-	-	-	-
Human Services	3,944	-	-	-	-	-
Disease Invest. & Response	-	-	-	-	-	-
<i>Total Health Transfers</i>	42,943	-	-	1,200	1,707	1,274
TOTAL HEALTH	8,802,901	8,839,321	8,829,302	9,772,415	9,773,286	9,898,093
<i>Percent Change from Previous Year</i>	11.4%	0.4%	-0.1%	10.7%	0.0%	1.3%

2005-2006 Funding Sources

	2005	2006
Licenses & Permits	667,440	684,650
Intergovernmental Revenue	4,936,129	4,925,265
I-695 Replacement Funding	876,000	876,000
Charges for Service	529,585	536,400
Taxes	327,500	327,500
Miscellaneous Revenue	94,212	9,064
Operating Transfers	92,293	92,293
General Fund	2,247,420	2,444,647
Total Funding	9,770,579	9,895,819

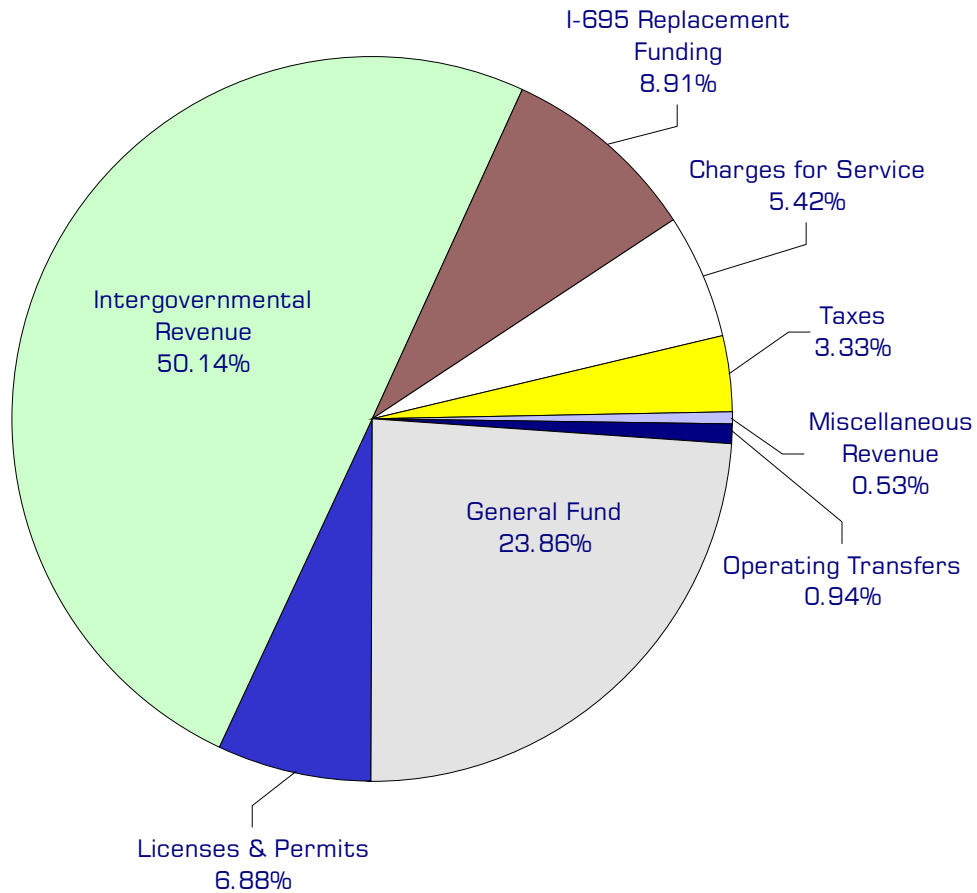

Funding Sources continued

Licenses & Permits

The Health and Human Services Department issues various licenses and permits. These include business licenses for restaurants, taverns and grocery stores, RV and mobile home parks, solid waste sites, sewage system designers, cleaners and installers, food handlers, water recreation facilities. Additionally, the department also grants noncommercial permits for septic tank installation and repair.

Intergovernmental Revenue

A variety of federal and state grants as well as intergovernmental payments for service are received by the department. These grants fund women, infant, and children programs, substance abuse counseling and recovery, developmentally disabled assistance, and communicable disease programs. The Health Department also receives funding from the City of Bellingham to support the Alcohol Protective Custody Program, and septic surveying services.

I-695 Replacement Funding

Initiative 695 repealed the motor vehicle excise tax in 1999. This is money that the state legislature provides to replace the lost funding.

Charges for Service

Fees for the provision of certain services the department provides such as sewage site inspections, building plan review, birth and death records, and immunizations.

Property Taxes

RCW 71.20.110 requires counties to levy two and one half cents per thousand dollars of assessed value for community services for persons with developmental disabilities or mental health problems.

Miscellaneous Revenue

Small amounts of revenue received from a variety of sources, including donations and contributions.

Operating Transfers

Operating transfer of \$87,293 from the Solid Waste Fund to support solid waste enforcement efforts. Operating transfer of \$5,000 from Community Development Fund to support mental health services.

General Fund

Undedicated General Fund resources.

Performance / Activity Measures

	Actual 2001	Actual 2002	Actual 2003	Projected 2004	Projected 2005	Projected 2006
<i>Administration</i>						
Birth certificates	5,500	9,375	7,479	7,900	7,900	7,900
Death certificates	1,700	1,703	1,467	1,800	1,800	1,800
Additional Death Certificates	5,000	5,593	4,479	4,600	4,600	4,600
<i>Community Health</i>						
<i>Child Health</i>						
Specialty Clinic Visits	143	120	111	110	110	110
<i>HIV/AIDS</i>						
Individuals participating in NEP referred to drug treatment	13	61	115	120	125	125
Needles exchanged in Needle Exchange Program (NEP)	37,130	84,853	130,000	135,000	140,000	145,000
<i>Immunization</i>						
Doses of state-supplied childrens' vaccine distributed to physician offices	53,687	48,741	54,895	56,000	57,000	58,000
Doses of vaccine administered in HD clinic	3,241	3,216	4,922	5,000	5,500	5,500
<i>Maternal Infant</i>						
Home visits	2,342	2,344	2,909	2,500	2,500	2,500
Births to teens under 18	58	55	47	45	45	45
<i>Nutrition</i>						
WIC women who initiated breast feeding	86%	87%	87%	88%	88%	88%
<i>Special Projects</i>						
Medicaid eligible children aged 0-5 who received dental services	34%	38%	40%	42%	45%	47%
<i>STD</i>						
Reported STD's receiving recommended treatment	92%	96%	92%	95%	95%	95%
<i>TB Control</i>						
People with active TB completing treatment	100%	100%	100%	100%	100%	100%
People completing treatment of latent TB	56%	72%	71%	80%	80%	80%
<i>Environmental Health</i>						
<i>Chemical & Physical Hazards</i>						
Clandestine drug lab incidents and investigations	2	11	22	30	30	30

continued on next page

Performance / Activity Measures continued

	Actual 2001	Actual 2002	Actual 2003	Projected 2004	Projected 2005	Projected 2006
<i>Drinking Water Program</i>						
Certificates for Drinking Water Availability issued	443	503	588	600	625	650
<i>Food Program</i>						
Routine food service inspections	1,470	1,070	1,045	1,500	1,500	1,500
Food service inspections resulting in scores > 35 critical violation points	1.2%	1.5%	3.1%	<5%	<5%	<5%
<i>Living Environment</i>						
Rabies post-exposure series administered	20	24	5	12	12	12
<i>On-Site Sewage</i>						
On-site sewage complaints/year	120	105	102	100	100	100
Septic System permits issued	590	695	744	750	750	750
Percent of Septic Tanks Pumped	6.6	7.4	7.6	8	10	10
<i>Solid Waste</i>						
Complaints/year	157	161	106	125	125	125
<i>Human Services</i>						
<i>Crisis Services Administration</i>						
Rate of Detox Admissions (duplicated per 100,000)	507	596	606	625	650	650
Rate of number of Detox clients (unduplicated per 100,000)	305	338	348	350	355	360
<i>Developmental Disabilities Services Administration</i>						
Individuals in employment programs	254	204	230	211	217	219
Participants in Community Access	61	65	76	80	82	84
Children in Early Intervention Programs	28	55	59	59	60	60
<i>Mental Health Services Administration</i>						
Monthly average clients receiving outpatient services	2,355	2,502	2600	2,700	2,800	2,900
Annual Number of Clients Screened at Crisis Phone Line	16,296	17,652	18,000	18,600	19,200	19,800
Involuntary detentions	403	390	400	410	415	420
<i>Substance Abuse Prevention</i>						
Juvenile alcohol & drug law arrests/100,000	1,890	1,870	1,870	1,900	1,890	1,890
Adult alcohol related arrests/100,000	1,660	1,550	1,550	1,600	1,650	1,650

continued on next page

Performance / Activity Measures continued

	Actual 2001	Actual 2002	Actual 2003	Projected 2004	Projected 2005	Projected 2006
<i>Substance Abuse Services Administration</i>						
Clients who successfully completed treatment	44%	58%	49%	52%	55%	56%
Rate of treatment admissions (duplicated per 100,000)	669	828	724	700	725	725
<i>Tobacco Prevention</i>						
Voluntary smoke-free public restaurants	205	207	215	242	250	260
Retailers that sell to minors during "compliance checks"	13.6%	19.0%	19.9%	6.5%	6.5%	6.5%

continued on next page

Expenditures Summary

	Actual 2001	Actual 2002	Actual 2003	Budget 2004	Budget 2005	Budget 2006
HEALTH						
Health Administration						
Salaries & Wages	610,999	646,747	688,024	663,390	518,958	526,758
Benefits	199,492	174,823	178,585	194,591	178,734	199,083
Supplies	32,683	36,845	34,417	37,100	35,100	35,600
Other Services & Charges	800,048	1,022,662	959,928	945,984	889,666	898,934
Capital Outlay	28,954	8,643	7,810	89,800	-	-
Operating Transfers	8,643	-	-	1,200	1,707	1,274
<i>Total Health Administration</i>	<i>1,680,819</i>	<i>1,889,720</i>	<i>1,868,764</i>	<i>1,932,065</i>	<i>1,624,165</i>	<i>1,661,649</i>
<i>Percent Change from Previous Year</i>	<i>13.0%</i>	<i>12.4%</i>	<i>-1.1%</i>	<i>3.4%</i>	<i>-15.9%</i>	<i>2.3%</i>
Community Health & Wellness						
Salaries & Wages	1,290,749	1,267,269	1,317,289	1,299,477	1,461,808	1,476,946
Benefits	504,458	489,696	515,354	525,424	495,468	550,928
Supplies	86,924	104,760	95,366	67,000	76,550	79,550
Other Services & Charges	163,579	136,935	79,281	74,445	67,425	63,325
Capital Outlay	11,466	1,132	-	3,000	-	-
Operating Transfers	20,631	-	-	-	-	-
<i>Total Community Health</i>	<i>2,077,807</i>	<i>1,999,792</i>	<i>2,007,290</i>	<i>1,969,346</i>	<i>2,101,251</i>	<i>2,170,749</i>
<i>Percent Change from Previous Year</i>	<i>-9.1%</i>	<i>-3.8%</i>	<i>0.4%</i>	<i>-1.9%</i>	<i>6.7%</i>	<i>3.3%</i>
Environmental Health						
Salaries & Wages	737,423	767,690	767,542	921,690	1,008,774	1,031,523
Benefits	268,003	236,968	226,543	254,000	304,429	340,687
Supplies	26,266	23,772	27,169	28,180	34,300	34,300
Other Services & Charges	235,858	174,276	155,634	144,095	139,440	135,240
Capital Outlay	-	-	-	9,000	1,000	1,000
Operating Transfers	9,725	-	-	-	-	-
<i>Total Environmental Health</i>	<i>1,277,275</i>	<i>1,202,706</i>	<i>1,176,888</i>	<i>1,356,965</i>	<i>1,487,943</i>	<i>1,542,750</i>
<i>Percent Change from Previous Year</i>	<i>19.7%</i>	<i>-5.8%</i>	<i>-2.1%</i>	<i>15.3%</i>	<i>9.7%</i>	<i>3.7%</i>
Human Services						
Salaries & Wages	321,664	326,131	316,457	321,015	351,602	359,153
Benefits	96,534	83,058	92,268	97,501	108,462	121,679
Supplies	59,165	29,206	31,692	20,350	25,369	23,659
Other Services & Charges	2,932,443	2,889,157	2,764,452	3,482,970	3,436,422	3,359,533
Capital Outlay	-	1,575	1,652	-	-	-
Operating Transfers	3,944	-	-	-	-	-
<i>Total Human Services</i>	<i>3,413,750</i>	<i>3,329,127</i>	<i>3,206,521</i>	<i>3,921,836</i>	<i>3,921,855</i>	<i>3,864,024</i>
<i>Percent Change from Previous Year</i>	<i>11.5%</i>	<i>-2.5%</i>	<i>-3.7%</i>	<i>22.3%</i>	<i>0.0%</i>	<i>-1.5%</i>

Expenditures Summary continued

	Actual 2001	Actual 2002	Actual 2003	Budget 2004	Budget 2005	Budget 2006
Disease Invest. & Response						
Salaries & Wages	281,839	345,079	499,372	512,864	448,184	453,158
Benefits	5	2,578	11,276	11,609	136,688	152,563
Supplies	24,173	24,627	24,230	22,500	27,500	27,500
Other Services & Charges	47,233	45,692	28,252	45,230	25,700	25,700
Capital Outlay	-	-	6,709	-	-	-
<i>Total Disease Invest. & Response</i>	<i>353,250</i>	<i>417,976</i>	<i>569,839</i>	<i>592,203</i>	<i>638,072</i>	<i>658,921</i>
<i>Percent Change from Previous Year</i>	<i>-88.5%</i>	<i>18.3%</i>	<i>36.3%</i>	<i>3.9%</i>	<i>7.7%</i>	<i>3.3%</i>
TOTAL HEALTH	8,802,901	8,839,321	8,829,302	9,772,415	9,773,286	9,898,093
<i>Percent Change from Previous Year</i>	<i>11.4%</i>	<i>0.4%</i>	<i>-0.1%</i>	<i>10.7%</i>	<i>0.0%</i>	<i>1.3%</i>

Services

Administration

Community Health Assessment

Regular and systematic process of collecting, analyzing and making available information on the health of a community, including statistics on health status and community health needs, and the conduct of epidemiological and other studies of health problems.

Vital Records

The Vital Records program is responsible for the registration of all deaths occurring in Whatcom County, the issuance of burial permits, and the issuance of certified death certificates for Whatcom County deaths.

Healthy Community Coalitions

The activity convenes groups to identify and address public health problems.

Community Health

Maternal & Child Services

Comprehensive health promotion and support services for pregnant women and families.

Children with Special Health Care Needs (CSHCN)

Family centered, coordinated services for children with special health care needs.

Sexually Transmitted Disease Surveillance

STD surveillance, prevention and technical assistance to health care providers.

HIV/AIDS

Health promotion activities to decrease high risk behaviors and referrals to services for persons who are HIV positive.

Public Health Nutrition

Provides supplemental foods, nutrition education and community referrals to low income participants.

Access to Baby and Childhood Dentistry (ABCD)

Increases the access and utilization of dental services for Medicaid eligible children under six.

Immunization Program

Administration of vaccine to target populations; distribution and oversight of state-supplied vaccines; consultation and quality assurance activities with health care providers.

Tuberculosis Program

Screening, diagnosis, treatment, and prevention of tuberculosis; consultation to and education of health care providers and the public.

Communicable Disease Investigation/Surveillance

Case investigation, contact notification, and surveillance for notifiable conditions. Education and consultation to the health care providers, and general public.

Services continued

Environmental Health

Emergency and Bioterrorism Response Planning

Public health emergency preparedness, response and recovery.

Drinking Water

Ensures safe drinking water for public through approval of water sources, public water supplies, well construction and investigation of disease outbreaks and complaints.

Food Protection

Prevention of food borne disease through inspection of food services and education of food workers. Investigation of food borne illness and complaints.

Living Environment Program

Drowning prevention, injury prevention and investigation of exposures to diseases like rabies, West Nile Virus and Lyme Disease, investigation of complaints.

On-Site Sewage Control

Permitting and inspection of on-site sewage systems.

Solid Waste Monitoring

Oversight of solid waste management and disposal practices through public education and regulatory enforcement.

Chemical/ Physical Hazards

Public health response to chemical releases, public exposure to toxic substances and investigations of contaminated sites.

Human Services

Mental Health Services Administration

Local contractors provide an array of mental health services that are not provided by the NSMHA. Coordinates in the administration, planning, and quality assurance of NSMHA-funded services in Whatcom County.

Developmental Disabilities Services Administration

Contracted employment training, day program and early intervention services for people with Developmental Disabilities.

2060 Housing Program

Administer distribution of funds collected from a low income housing surcharge on document recording fees. Funds are to be used to benefit persons with incomes at or below 50% of Whatcom County's median income. Fund may be used for: acquiring or rehabilitating housing projects, supporting housing projects' operation and maintenance, rental assistance vouchers and operating costs of emergency shelters.

Services continued

Substance Abuse Treatment Services Administration

Whatcom County provides a comprehensive continuum of substance abuse services through subcontracts with local private and non-profit treatment providers.

Substance Abuse Crisis Services Administration

Local contractors provide comprehensive crisis intervention services, including social detoxification, outreach & engagement, case management, and involuntary commitment services.

Substance Abuse Prevention Program

The Substance Abuse Prevention Program provides services directly and through “best practice” service contracts. All prevention activities work to reduce the risks and increase protective factors in program participants.

Tobacco Prevention Program

Program activities reduce youth access to tobacco, increase resources for quitting, reduce second hand smoke, and increase local capacity to prevent the use of tobacco products.

Hearing Examiner

Serves as a quasi-judicial officer to hear, evaluate, and decide specific land use and development proposals.

- No legislative function - applies laws and ordinances passed by the County Council.
- Public hearings are generally held weekly, as needed. Please call for current schedule.
- Files are available for public review by appointment.

FTE's for this department

Year	2001	2002	2003	*2004	*2005	*2006
FTE	1.00	1.00	1.00	1.00	1.00	1.00

**budget*

The chart below shows the organizational structure for 2005 only.

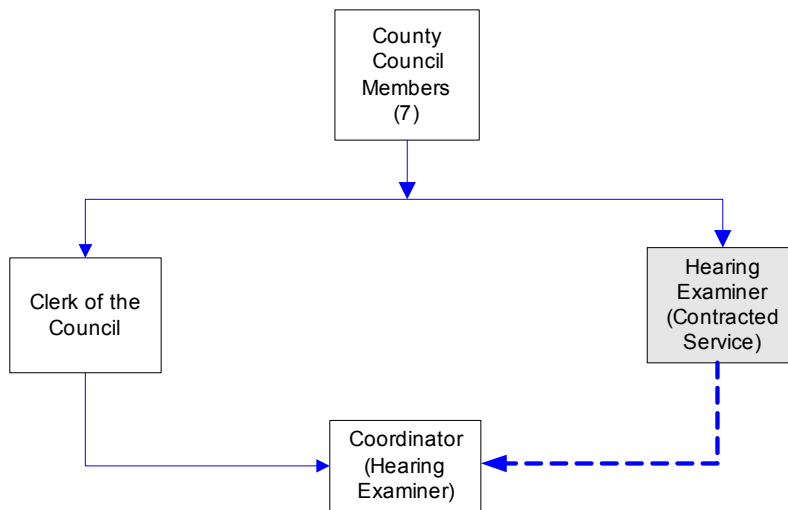

Mission & Objectives

Mission

Provide Whatcom County with a system for considering and applying regulatory enactments which will best satisfy the following:

- 1) The need to separate the application of regulatory land controls from planning;
- 2) The need to better protect and promote the interest of the public and private elements of the community; and
- 3) The need to expand the principles of fairness and due process in open record hearings.

Objectives

- Conduct open record hearings on regulatory enactments on behalf of the County Council in accordance with guidelines set forth in the Open Public Meetings Act.
- Submit all recommendations and decisions to the County Council in a timely manner, as required by law.
- Integrate growth management, SEPA, shoreline and other processes as required.
- With assistance from County Council staff, prepare records from the 1970's and 1980's for archiving.
- Review storage and office space issues with the Administration and make adjustments where necessary.
- Review and adjust office procedures in order to better accommodate the increased workload created by Health Department appeals, site specific rezones, and flood variances/appeals.

Expenditure Trends

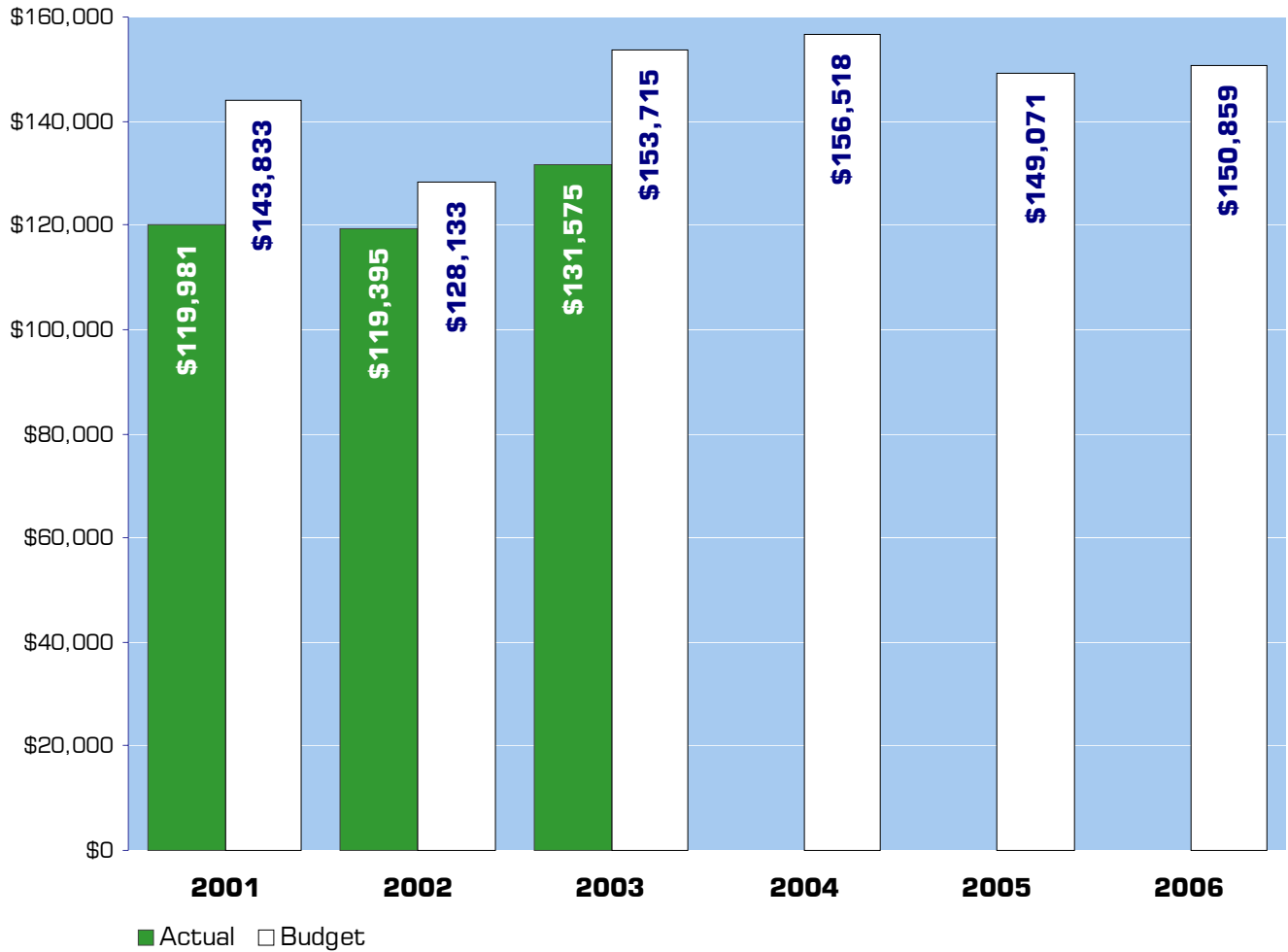

NOTE: Capital expenditures and interfund operating transfers are not shown to more accurately reflect ongoing operational costs.

2005-2006 Budget by Program

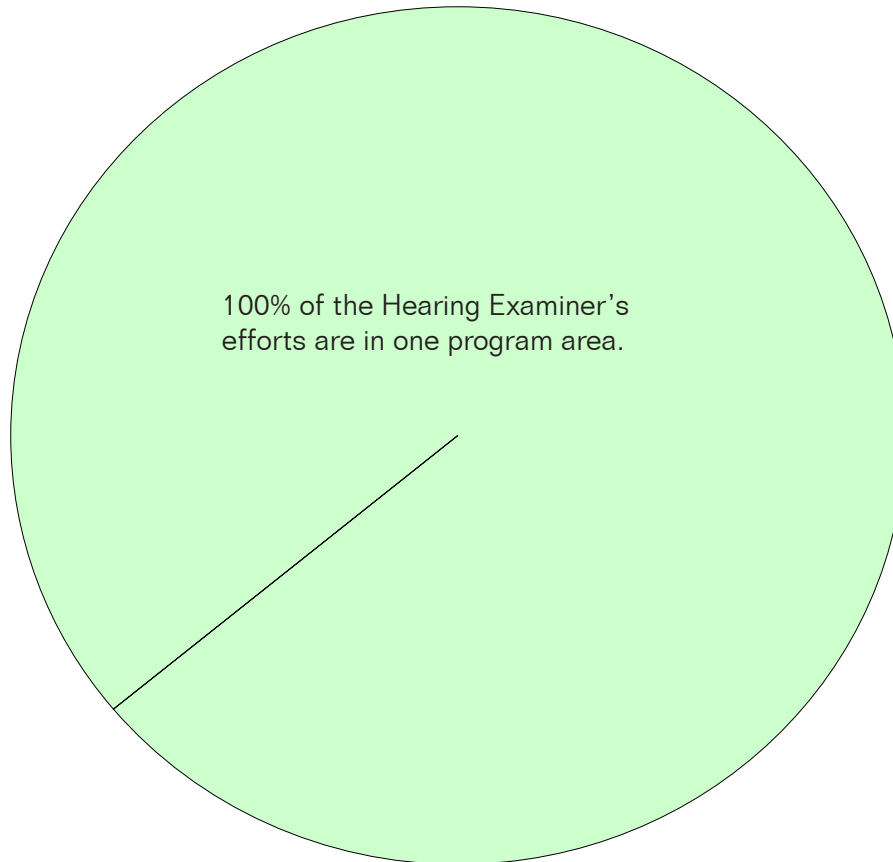

NOTE: Capital expenditures and interfund operating and residual equity transfers are not shown to more accurately reflect ongoing operational costs.

Program Summary

Actual 2001	Actual 2002	Actual 2003	Budget 2004	Budget 2005	Budget 2006
----------------	----------------	----------------	----------------	----------------	----------------

OPERATIONS

General Fund

1600 Hearing Examiner	119,981	119,395	131,575	156,518	149,071	150,859
<i>Total Hearing Examiner Operations</i>	119,981	119,395	131,575	156,518	149,071	150,859

TRANSFERS

General Fund

1600 Hearing Examiner	492	-	-	-	-	-
<i>Total Hearing Examiner Transfers</i>	492	-	-	-	-	-

TOTAL HEARING EXAMINER	120,473	119,395	131,575	156,518	149,071	150,859
<i>Percent Change from Previous Year</i>	6.1%	-0.9%	10.2%	19.0%	-4.8%	1.2%

2005-2006 Funding Sources

	2005	2006
General Fund	149,071	150,859
Total Funding	149,071	150,859

General Fund

Undedicated General Fund resources.

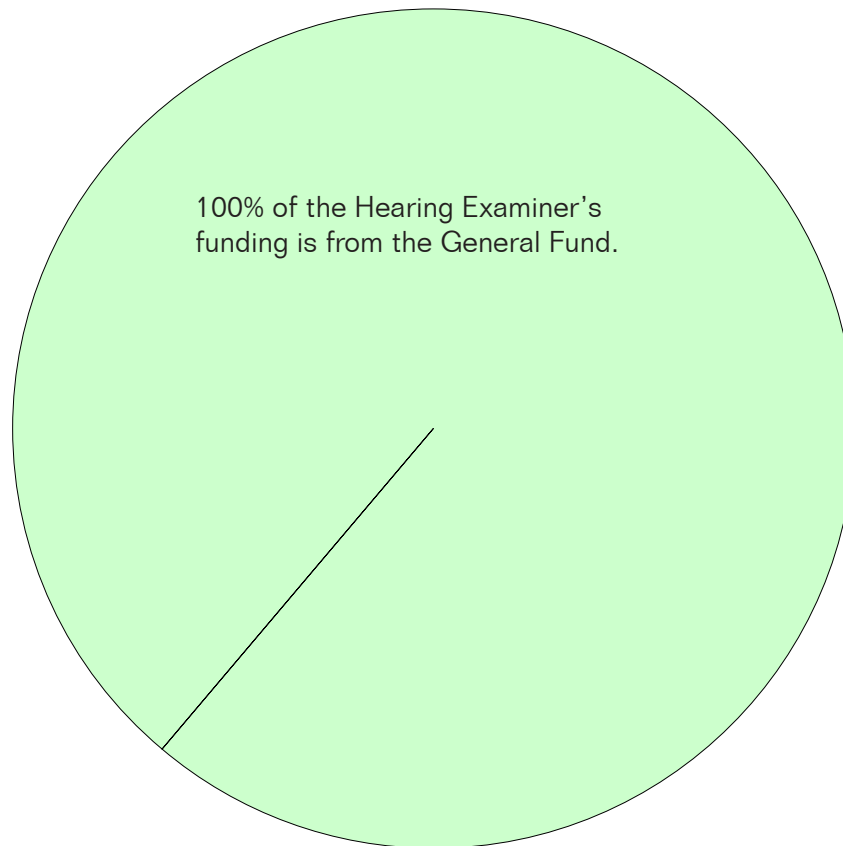

Performance / Activity Measures

	Actual 2001	Actual 2002	Actual 2003	Projected 2004	Projected 2005	Projected 2006
Revocations			3	1	1	1
Shoreline Applications	26	36	31	33	36	39
Administrative Appeals	7	7	9	12	15	18
SEPA Appeals			1	2	2	2
Flood Appeals			1	1	1	1
Planned Unit Developments				2	3	3
Revisions	30	30	30	30	30	30
Council Remands			1	1	1	1
Public Hearings	95	87	82	95	98	100
Subdivisions			4	7	10	10

Expenditures Summary

	Actual 2001	Actual 2002	Actual 2003	Budget 2004	Budget 2005	Budget 2006
GENERAL FUND						
1600 Hearing Examiner						
Salaries & Wages	37,726	37,800	41,811	41,688	41,748	41,808
Benefits	9,851	9,814	11,099	12,077	13,691	15,229
Supplies	1,103	1,478	553	3,690	3,690	3,690
Other Services & Charges	71,301	70,303	78,112	99,063	89,942	90,132
Operating Transfers	492	-	-	-	-	-
TOTAL HEARING EXAMINER	120,473	119,395	131,575	156,518	149,071	150,859
<i>Percent Change from Previous Year</i>	6.1%	-0.9%	10.2%	19.0%	-4.8%	1.2%

Services

Office Operation, Public Hearings, Decision Processing

The Hearing Examiner, on behalf of the county council, considers the applications of regulatory enactments to land use developers and property owners seeking land use and shoreline permits.



Juvenile Court Administration

Through the Juvenile Court, Detention Center and a number of special programs, this department provides services to assist young offenders with personal and/or environmental problems which get them into trouble with law. The Juvenile Detention Facility is located on the 6th floor of the courthouse. (Visiting hours are limited. Call for schedule.)

FTE's for this department

Year	2001	2002	2003	*2004	*2005	*2006	*budget
FTE	49.75	47.00	45.00	45.10	45.80	45.80	

The chart below shows the organizational structure for 2005 only.

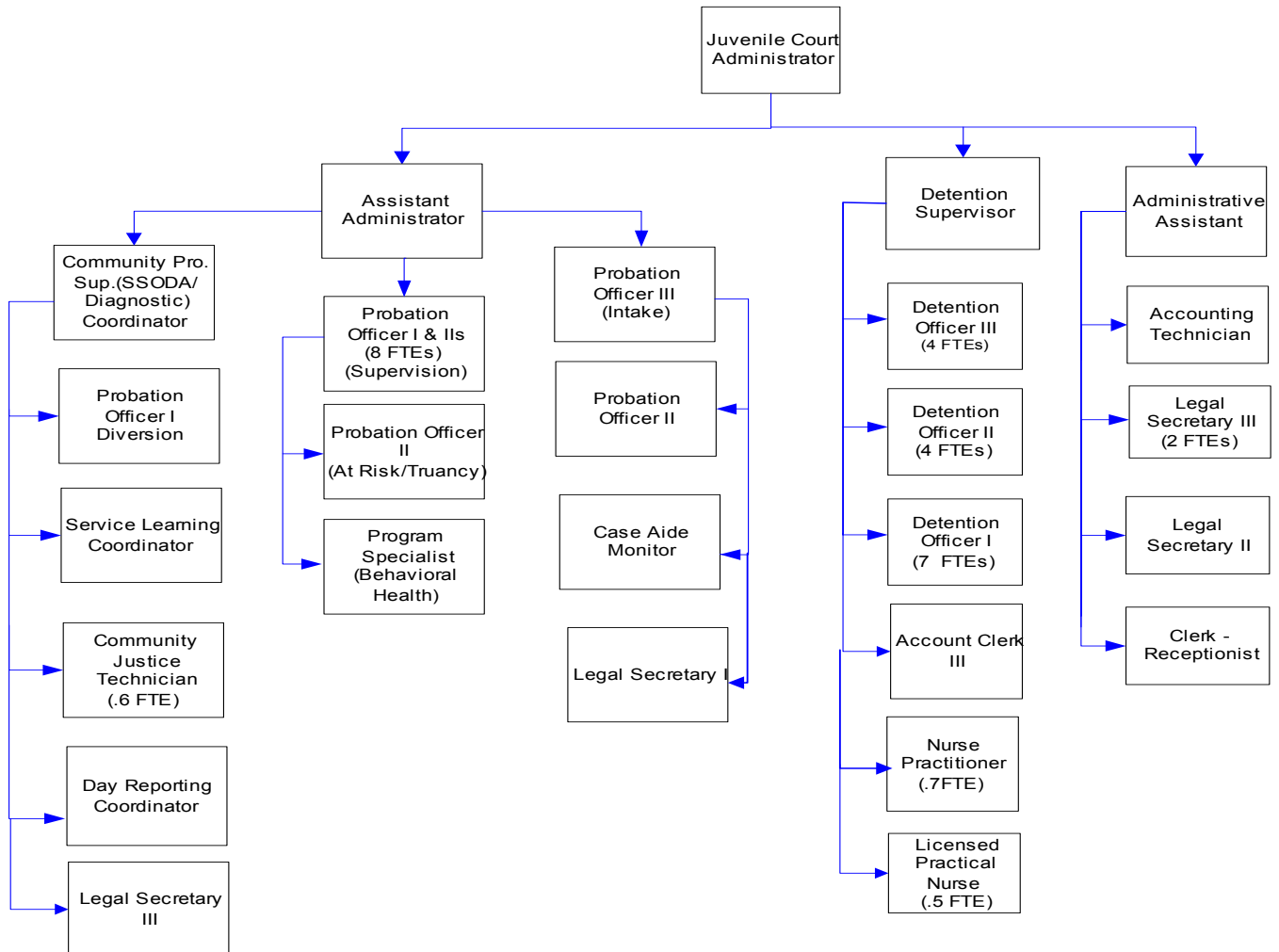

Mission & Objectives

Mission

Whatcom County Juvenile Court Administration strives to be a catalyst for developing safe communities and healthy youth and families by:

- Holding offenders accountable for their actions.
- Establishing and maintaining effective communication with the community around youth at risk in order to achieve cooperation in making appropriate decisions and receive support in developing and using services and resources.
- Providing a range of community programs and services to meet the individual needs of the youth we serve. This includes educational support, vocational training, recreation, mental health and specialized programs such as anger management, conflict resolution, sex offender treatment and substance abuse treatment.
- Involving the victim, family and community as preferred resources and using a case management model to provide results-based and outcome-driven interventions and practices.
- Utilizing the Washington Juvenile Court Administrators Risk Assessment tool to identify and address the needs of juvenile offenders while maintaining public safety at all times.
- Maintaining a safe and secure detention facility that will provide graduated sanctions for juvenile offenders and public safety for victims and the community.
- Obtaining and sustaining sufficient resources.

- Promoting growth and development of all juvenile justice professionals.
- Providing a safe, secure environment for staff and juveniles.

Objectives

Administration

- Increase restitution collected and paid to victims from \$65,000 in 2004 to \$70,000 in 2005 and 2006.
- Decrease the average length of stay in detention from 8.2 days in 2004 to 8 days in 2005 and 2006 by increasing utilization of alternative sanctions.
- Reduce the number of youth issued Failure to Appear (FTA) warrants from an estimated 260 in 2004 to 245 in 2005-2006.
- Reduce the number of youth issued probation violation warrants from an estimated 220 in 2004 to 200 in 2005-2006.
- Seek funding to implement a paid work experience program at the Juvenile Community Justice Center to increase payment of restitution to victims.
- Implement a work readiness program at the Juvenile Community Justice Center to increase the number of offenders who are employed in order to increase payment of restitution to victims.
- Increase the number of youth served in the Juvenile Drug Court from 15 in 2004 to 17 in 2005-2006.

Objectives continued

- Utilizing the new case management system, compile the following baseline data for the year for 2005 and beyond:
 - Detention bed days ordered and served for probation violations.
 - Number of days ordered and served for Electronic Home Monitoring.
 - Number of days ordered and served in the Day Reporting program.
 - Community service hours ordered.
 - Community service hours completed.
 - Number of youth discharged early from community supervision.
 - Number of youth discharged with successful completion of requirements.
 - Number of youth discharged without successfully completing requirements.
 - Number of youth adjudicated of a new offense while on community supervision.
- Ensure 80% of juvenile offenders are seen by their probation officers within 20 minutes of their scheduled probation appointments.

Expenditure Trends

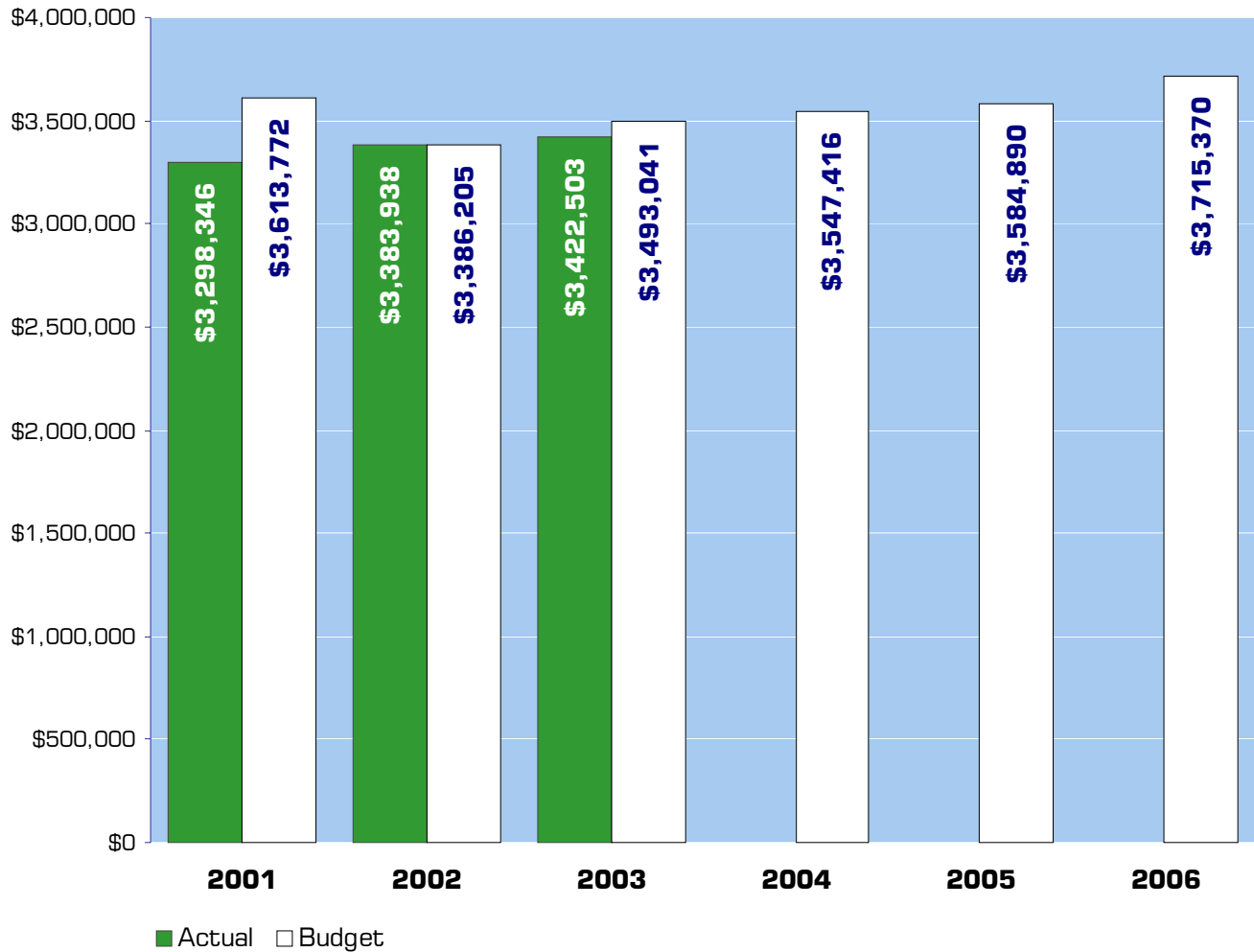

NOTE: Capital expenditures and interfund operating transfers are not shown to more accurately reflect ongoing operational costs.

2005-2006 Budget by Program

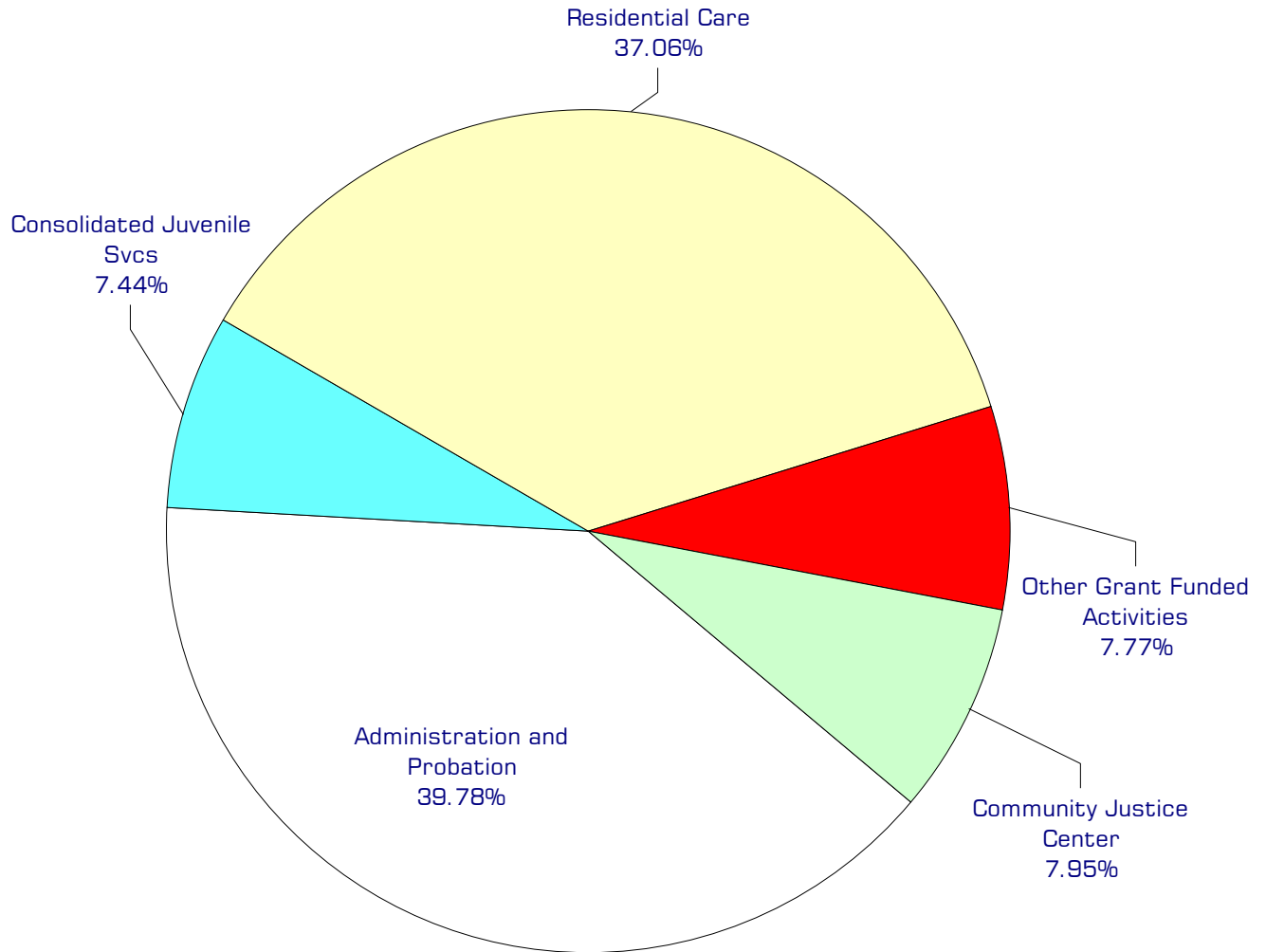

NOTE: Capital expenditures and residual equity transfers are not shown to more accurately reflect ongoing operational costs.

Program Summary

	Actual 2001	Actual 2002	Actual 2003	Budget 2004	Budget 2005	Budget 2006
OPERATIONS						
General Fund						
1900 Juvenile Court- Admin	1,079,130	1,086,670	1,187,014	1,444,421	1,424,125	1,479,844
1941 Juvenile Court-Hlth Ch Girls	15,217	56,585	44,129	25,873	-	-
1945 Comm Justice Center	103,200	207,281	157,930	298,521	284,798	295,275
1950 Juvenile Court-CJS	328,784	330,477	308,673	259,251	268,379	274,782
1953 Parole Detention	64,172	47,307	52,759	51,035	59,153	61,691
1954 Commit Alt	12,628	-	-	-	-	-
1957 Community Bld	23,154	-	-	-	-	-
1959 Becca Bill	129,908	54,190	56,059	66,687	69,358	71,086
1960 Trans	12,459	5,928	-	-	-	-
1961 DSHS	67,591	62,204	38,948	1,750	1,750	1,750
1962 CDDA Grant	-	23,680	58,081	59,077	59,077	59,983
1963 CJAA-DSHS Misc	43,797	33,138	51,790	75,803	75,803	79,290
1964 Juvenile Court - Teen Court	83,974	72,714	33,297	15,000	18,500	10,000
1965 GJJAC-JDAI	-	-	-	9,729	-	-
1970 Residential Care	1,038,419	1,008,540	988,039	1,240,269	1,323,947	1,381,669
1971 Work Crew	23,431	54,361	101,177	-	-	-
1980 Medical/ Dental	15,615	15,863	9,766	-	-	-
1985 Alcoa	-	8,510	27,980	-	-	-
1990 Facilities	252,537	312,090	302,344	-	-	-
1995 DOE Comm Litter Clean	4,330	4,400	4,517	-	-	-
<i>Total Juvenile Court Operations</i>	3,298,346	3,383,938	3,422,503	3,547,416	3,584,890	3,715,370
CAPITAL						
General Fund						
1900 Juvenile Court- Admin	-	1,587	1,385	59,000	-	-
1945 Comm Justice Center	-	-	-	500	500	500
1953 Parole Detention	1,531	-	-	-	849	849
1959 Juvenile Court Becca Bill	3,074	-	-	-	-	-
1963 CJAA-DSHS Misc	-	1,721	-	-	-	-
1970 Residential Care	2,627	1,084	1,459	-	10,000	-
1971 Work Crew	-	1,527	-	-	-	-
<i>Total Juvenile Court Capital</i>	7,232	5,919	2,844	59,500	11,349	1,349

continued on next page

Program Summary continued

	Actual 2001	Actual 2002	Actual 2003	Budget 2004	Budget 2005	Budget 2006
TRANSFERS						
General Fund						
1900 Juvenile Court- Admin	9,058	-	-	-	-	-
1945 Comm Justice Center	1,076	-	2,763	3,000	3,000	3,000
1950 CJS	2,359	4,463	-	-	-	-
1953 Parole Detention	731	-	-	-	-	-
1954 Commit Alt Pr	555	-	-	-	-	-
1959 Juvenile Court Becca Bill	1,244	-	-	-	-	-
1961 DSHS	647	-	-	-	-	-
1963 CJAA-DSHS Misc	91	-	-	-	-	-
1970 Residential Care	9,625	-	-	-	-	-
1971 Work Crew	445	-	-	-	-	-
<i>Total Juvenile Court Transfers</i>	25,831	4,463	2,763	3,000	3,000	3,000
TOTAL JUVENILE COURT ADMIN	3,331,409	3,394,320	3,428,110	3,609,916	3,599,239	3,719,719
<i>Percent Change from Previous Year</i>	8.9%	1.9%	1.0%	5.3%	-0.3%	3.3%

2005-2006 Funding Sources

	2005	2006
Service Charges & Fees	53,000	53,000
General Fund	2,936,599	3,060,017
Intergovernmental Revenues	569,291	584,353
Miscellaneous Revenues	20,000	12,000
Operating Transfer-Solid Waste	6,000	6,000
Total Funding	3,584,890	3,715,370

Service Charges & Fees

Juvenile Court rents available detention space to other jurisdictions at the rate of \$110 per youth per day. The department also charges for copy fees.

General Fund

Undedicated General Fund resources.

Operating Transfer - Solid Waste

Payment from Solid Waste for supervisor of detention's Juvenile Litter Crews.

Intergovernmental Revenues

Several Juvenile Services programs are funded by state grants and reimbursements. Most grants are biennial grants with an agreement period from July 1 through June 30 each biennium. These grants fund various programs including intervention activities, parole violator detention, diversion programs, sex offender treatment, and substance abuse treatment for juveniles.

Miscellaneous Revenue

Includes contributions and revenue from detainee phone usage from Qwest.

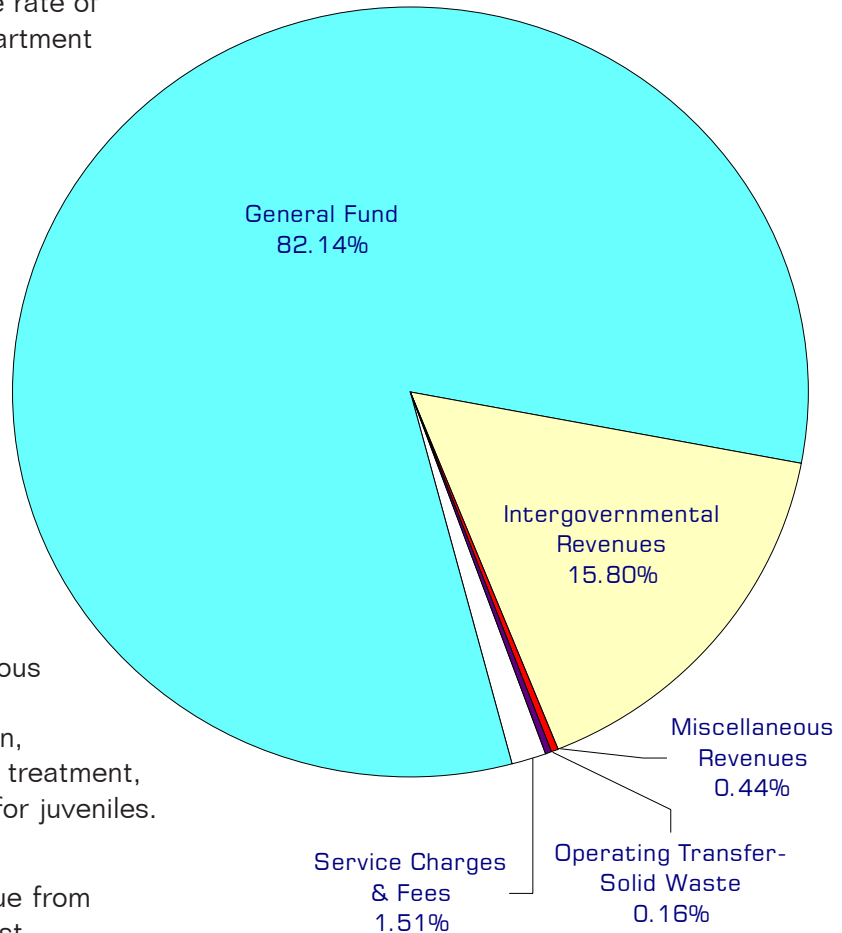

Performance / Activity Measures

	Actual 2001	Actual 2002	Actual 2003	Projected 2004	Projected 2005	Projected 2006
<i>Detention</i>						
Population (Offenders)	1,053	1,092	1,148	1,100	1,150	1,200
Population (Offenders) Bed Days	9,818	9,816	10,000	8,916	9,000	9,000
Average Length of Stay - Bed Days	8.92	8.9	8.35	8.2	8	8
At-Risk/Contempts	38	72	119	80	85	85
At-Risk/Contempts - Bed Days	130	163	176	192	195	195
Truancy/Contempts - Bed Days	11	22	67	75	75	75
<i>Probation</i>						
<i>Community Supervision</i>						
Referred to Diversion	608	680	576	624	625	625
Diversion Agreements Entered	547	508	507	550	550	550
Diversion Agreements Completed	437	426	431	450	475	475
Assigned to Community Supervision	720	736	700	634	650	650
Restitution Collected	\$ 76,056	\$ 45,000	\$ 55,000	\$ 65,000	\$ 70,000	\$ 70,000
<i>Court Services</i>						
Cases Filed	839	868	830	799	750	800
Proceedings Held	2,768	3,423	3,500	3,600	3,500	3,600
At-Risk Youth (ARY) Petitions Filed	60	42	56	50	50	50
Children in Need of Services' Petitions Filed	11	7	14	8	10	10
Dependencies Filed	95	71	83	87	85	85

Expenditures Summary

	Actual 2001	Actual 2002	Actual 2003	Budget 2004	Budget 2005	Budget 2006
GENERAL FUND						
1900 Juvenile Court Administration						
Salaries & Wages	680,633	714,243	809,501	883,305	850,831	867,242
Benefits	175,175	172,956	204,009	238,783	266,819	298,583
Supplies	17,166	27,059	23,891	25,650	25,650	25,650
Other Services & Charges	206,156	172,412	149,613	296,683	280,825	288,369
Capital Outlay	-	1,587	1,385	59,000	-	-
Operating Transfers	9,058	-	-	-	-	-
<i>Total Juvenile Ct Admin.</i>	1,088,188	1,088,257	1,188,399	1,503,421	1,424,125	1,479,844
<i>Percent Change from Previous Year</i>	17.5%	0.0%	9.2%	26.5%	-5.3%	3.9%
1941 Juvenile Ct - Healthy Choices Girls						
Other Services & Charges	15,217	56,585	44,129	25,873	-	-
<i>Total Juvenile Ct Healthy Choice Girl</i>	15,217	56,585	44,129	25,873	-	-
<i>Percent Change from Previous Year</i>	0.0%	271.9%	-22.0%	-41.4%	-100.0%	0.0%
1945 Juvenile Court - Comm Justice Center						
Salaries & Wages	47,433	86,184	43,109	151,776	137,449	141,847
Benefits	10,446	21,689	11,492	49,988	55,035	61,114
Supplies	8,417	14,027	3,424	6,050	6,050	6,050
Other Services & Charges	36,904	85,381	99,905	90,707	86,264	86,264
Capital Outlay	-	-	-	500	500	500
Operating Transfers	1,076	-	2,763	3,000	3,000	3,000
<i>Total Juvenile Ct -Comm Justice Ctr</i>	104,276	207,281	160,693	302,021	288,298	298,775
<i>Percent Change from Previous Year</i>	0.0%	98.8%	-22.5%	87.9%	-4.5%	3.6%
1950 Juvenile Court - CJS						
Salaries & Wages	173,823	186,746	161,494	122,673	122,636	124,636
Benefits	45,384	45,165	42,523	34,444	36,461	40,862
Supplies	3,034	4,668	2,384	2,700	2,700	2,700
Other Services & Charges	106,543	93,898	102,272	99,434	106,582	106,584
Operating Transfers	2,359	4,463	-	-	-	-
<i>Total Juvenile Ct - CJS</i>	331,143	334,940	308,673	259,251	268,379	274,782
<i>Percent Change from Previous Year</i>	-9.7%	1.1%	-7.8%	-16.0%	3.5%	2.4%
1953 Juvenile Court - Parole Detention						
Salaries & Wages	49,538	35,275	41,753	36,873	37,923	39,020
Benefits	12,783	8,769	11,006	10,830	11,730	13,171
Supplies	1,851	386	-	-	1,500	1,500
Other Services & Charges	-	2,877	-	3,332	8,000	8,000
Capital Outlay	1,531	-	-	-	849	849
Operating Transfers	731	-	-	-	-	-
<i>Total Juvenile Ct - Parole Det.</i>	66,434	47,307	52,759	51,035	60,002	62,540
<i>Percent Change from Previous Year</i>	-16.1%	-28.8%	11.5%	-3.3%	17.6%	4.2%

continued on next page

Expenditures Summary continued

	Actual 2001	Actual 2002	Actual 2003	Budget 2004	Budget 2005	Budget 2006
1954 Juvenile Court - Commit Alt Pr						
Salaries & Wages	9,198	-	-	-	-	-
Benefits	2,469	-	-	-	-	-
Supplies	-	-	-	-	-	-
Other Services & Charges	961	-	-	-	-	-
Operating Transfers	555	-	-	-	-	-
<i>Total Juvenile Ct - Commit</i>	<i>13,183</i>	<i>-</i>	<i>-</i>	<i>-</i>	<i>-</i>	<i>-</i>
<i>Percent Change from Previous Year</i>	<i>-69.7%</i>	<i>-100.0%</i>	<i>0.0%</i>	<i>0.0%</i>	<i>0.0%</i>	<i>0.0%</i>
1957 Juvenile Court - Community Bld						
Other Services & Charges	23,154	-	-	-	-	-
<i>Total Juvenile Ct - Community Bld</i>	<i>23,154</i>	<i>-</i>	<i>-</i>	<i>-</i>	<i>-</i>	<i>-</i>
<i>Percent Change from Previous Year</i>	<i>-37.9%</i>	<i>-100.0%</i>	<i>0.0%</i>	<i>0.0%</i>	<i>0.0%</i>	<i>0.0%</i>
1959 Juvenile Court - Becca Bill						
Salaries & Wages	83,897	43,462	43,609	51,015	52,164	52,164
Benefits	23,619	10,728	11,590	13,150	14,944	16,672
Supplies	1,869	-	-	500	500	500
Other Services & Charges	20,523	-	860	2,022	1,750	1,750
Capital Outlay	3,074	-	-	-	-	-
Operating Transfers	1,244	-	-	-	-	-
<i>Total Juvenile Ct - Becca Bill</i>	<i>134,226</i>	<i>54,190</i>	<i>56,059</i>	<i>66,687</i>	<i>69,358</i>	<i>71,086</i>
<i>Percent Change from Previous Year</i>	<i>71.1%</i>	<i>-59.6%</i>	<i>3.4%</i>	<i>19.0%</i>	<i>4.0%</i>	<i>2.5%</i>
1960 Juvenile Court - Trans.						
Other Services & Charges	12,459	5,928	-	-	-	-
<i>Total Juvenile Ct - Trans.</i>	<i>12,459</i>	<i>5,928</i>	<i>-</i>	<i>-</i>	<i>-</i>	<i>-</i>
<i>Percent Change from Previous Year</i>	<i>3.4%</i>	<i>-52.4%</i>	<i>-100.0%</i>	<i>0.0%</i>	<i>0.0%</i>	<i>0.0%</i>
1961 Juvenile Court - DSHS						
Salaries & Wages	48,918	38,923	20,259	-	-	-
Benefits	13,073	12,869	8,915	-	-	-
Supplies	-	606	136	600	600	600
Other Services & Charges	5,600	9,806	9,638	1,150	1,150	1,150
Operating Transfers	647	-	-	-	-	-
<i>Total Juvenile Ct - DSHS</i>	<i>68,238</i>	<i>62,204</i>	<i>38,948</i>	<i>1,750</i>	<i>1,750</i>	<i>1,750</i>
<i>Percent Change from Previous Year</i>	<i>-15.5%</i>	<i>-8.8%</i>	<i>-37.4%</i>	<i>-95.5%</i>	<i>0.0%</i>	<i>0.0%</i>
1962 Juvenile Court - CDDA Grant						
Salaries & Wages	-	5,006	18,709	26,442	26,472	26,502
Benefits	-	1,192	4,512	6,665	7,517	8,393
Supplies	-	206	995	2,070	2,070	2,070
Other Services & Charges	-	17,276	33,865	23,900	23,018	23,018
<i>Total Juvenile Ct - CDDA Grant</i>	<i>-</i>	<i>23,680</i>	<i>58,081</i>	<i>59,077</i>	<i>59,077</i>	<i>59,983</i>
<i>Percent Change from Previous Year</i>	<i>-100.0%</i>	<i>0.0%</i>	<i>145.3%</i>	<i>1.7%</i>	<i>0.0%</i>	<i>1.5%</i>

continued on next page

Expenditures Summary continued

	Actual 2001	Actual 2002	Actual 2003	Budget 2004	Budget 2005	Budget 2006
1963 Juvenile Court - CJAA-DSHS Misc						
Salaries & Wages	5,253	12,990	24,558	33,672	43,540	45,221
Benefits	1,379	3,622	7,027	9,470	15,648	17,452
Supplies	160	2,478	3,266	3,000	1,002	1,002
Other Services & Charges	37,005	14,048	16,939	29,661	15,613	15,615
Capital Outlay	-	1,721	-	-	-	-
Operating Transfers	91	-	-	-	-	-
<i>Total Juvenile Ct-CJAA-DSHS</i>	<i>43,888</i>	<i>34,859</i>	<i>51,790</i>	<i>75,803</i>	<i>75,803</i>	<i>79,290</i>
<i>Percent Change from Previous Year</i>	<i>-28.6%</i>	<i>-20.6%</i>	<i>48.6%</i>	<i>46.4%</i>	<i>0.0%</i>	<i>4.6%</i>
1964 Juvenile Court - Teen Court						
Other Services & Charges	83,974	72,714	33,297	15,000	18,500	10,000
<i>Total Juvenile Ct - Teen Court</i>	<i>83,974</i>	<i>72,714</i>	<i>33,297</i>	<i>15,000</i>	<i>18,500</i>	<i>10,000</i>
<i>Percent Change from Previous Year</i>	<i>297.2%</i>	<i>-13.4%</i>	<i>-54.2%</i>	<i>-55.0%</i>	<i>23.3%</i>	<i>-45.9%</i>
1965 Juvenile Court - GJJAC - JDAI						
Salaries & Wages	-	-	-	2,500	-	-
Benefits	-	-	-	229	-	-
Supplies	-	-	-	1,900	-	-
Other Services & Charges	-	-	-	5,100	-	-
<i>Total Juvenile Ct - GJJAC-JDAI</i>	<i>-</i>	<i>-</i>	<i>-</i>	<i>9,729</i>	<i>-</i>	<i>-</i>
<i>Percent Change from Previous Year</i>	<i>0.0%</i>	<i>0.0%</i>	<i>0.0%</i>	<i>0.0%</i>	<i>-100.0%</i>	<i>0.0%</i>
1970 Juvenile Court - Res. Care						
Salaries & Wages	767,730	772,197	755,377	734,793	760,263	787,948
Benefits	196,246	186,232	197,891	232,226	284,237	314,274
Supplies	25,335	21,500	23,380	59,872	88,200	88,200
Other Services & Charges	49,108	28,611	11,391	213,378	191,247	191,247
Capital Outlay	2,627	1,084	1,459	-	10,000	-
Operating Transfers	9,625	-	-	-	-	-
<i>Total Juvenile Ct - Res. Care</i>	<i>1,050,671</i>	<i>1,009,624</i>	<i>989,498</i>	<i>1,240,269</i>	<i>1,333,947</i>	<i>1,381,669</i>
<i>Percent Change from Previous Year</i>	<i>0.4%</i>	<i>-3.9%</i>	<i>-2.0%</i>	<i>25.3%</i>	<i>7.6%</i>	<i>3.6%</i>
1971 Juvenile Work Crew						
Salaries & Wages	16,859	35,291	76,051	-	-	-
Benefits	5,483	9,315	23,048	-	-	-
Supplies	279	1,976	1,237	-	-	-
Other Services & Charges	810	7,779	841	-	-	-
Capital Outlay	-	1,527	-	-	-	-
Operating Transfers	445	-	-	-	-	-
<i>Total Juvenile Ct Work Crew</i>	<i>23,876</i>	<i>55,888</i>	<i>101,177</i>	<i>-</i>	<i>-</i>	<i>-</i>
<i>Percent Change from Previous Year</i>	<i>-46.6%</i>	<i>134.1%</i>	<i>81.0%</i>	<i>-100.0%</i>	<i>0.0%</i>	<i>0.0%</i>
1980 Juvenile Court - Medical/Dental						
Supplies	6,849	9,040	6,705	-	-	-
Other Services & Charges	8,766	6,823	3,061	-	-	-
<i>Total Juvenile Ct - Med/Dental</i>	<i>15,615</i>	<i>15,863</i>	<i>9,766</i>	<i>-</i>	<i>-</i>	<i>-</i>
<i>Percent Change from Previous Year</i>	<i>-0.2%</i>	<i>1.6%</i>	<i>-38.4%</i>	<i>-100.0%</i>	<i>0.0%</i>	<i>0.0%</i>

continued on next page

Expenditures Summary continued

	Actual 2001	Actual 2002	Actual 2003	Budget 2004	Budget 2005	Budget 2006
1985 Juvenile Court - Alcoa						
Salaries & Wages	-	6,285	21,039	-	-	-
Benefits	-	1,860	6,411	-	-	-
Supplies	-	365	71	-	-	-
Other Services & Charges	-	-	459	-	-	-
<i>Total Juvenile Ct - Alcoa</i>	-	8,510	27,980	-	-	-
<i>Percent Change from Previous Year</i>	0.0%	0.0%	228.8%	-100.0%	0.0%	0.0%
1990 Juvenile Court - Facilities						
Other Services & Charges	252,537	312,090	302,344	-	-	-
<i>Total Juvenile Ct. - Facilities</i>	252,537	312,090	302,344	-	-	-
<i>Percent Change from Previous Year</i>	6.0%	23.6%	-3.1%	-100.0%	0.0%	0.0%
1995 Juvenile - DOE Comm Litter Clean						
Salary & Wages	3,834	3,874	3,926	-	-	-
Benefits	496	526	591	-	-	-
<i>Total Juvenile Ct - DOE</i>	4,330	4,400	4,517	-	-	-
<i>Percent Change from Previous Year</i>	0.0%	0.0%	-80.5%	-100.0%	0.0%	0.0%
TOTAL JUVENILE COURT	3,331,409	3,394,320	3,428,110	3,609,916	3,599,239	3,719,719
<i>Percent Change from Previous Year</i>	8.9%	1.9%	1.0%	5.3%	-0.3%	3.3%

Services

Community Supervision (Probation)

The supervision of juvenile offenders by probation officers as defined by the order of disposition by the court or conditions contained in an individualized agreement between probation officer and offender.

Court Services/Intake

Provides court-related information requested by the judge, prosecutor, and public defender; keeps offenders informed of all hearings; administers short-form risk assessment; provides pre-trial monitoring.

Community Justice Accountability Act (CJAA)

Provides Aggression Replacement Training (ART), Family Functional Therapy (FFT) and coordination of services to youth and their families.

Parole Detention/Diagnostics

Custody & care of youth held in detention who are under JRA Parole Supervision or pending transportation to the institutions. Pre/post diagnostic report writing on youth committed to JRA.

Juvenile Detention

Juvenile Detention is a safe and secure environment for youth who have been arrested pending a court appearance or who have been sentenced to serve time after a court appearance.

Community Justice Programs

Community justice programs provide community-based alternatives to detention and case management support for probation officers.

Consolidated Juvenile Services - Diversion

Eligible minor & first offenders are referred to the Diversion Unit, where they may choose to enter a diversion agreement in lieu of going to court and being placed on probation.

Consolidated Juvenile Services - SSODA

All first-time adjudicated felony sex offenders are evaluated for risk to the community and suitability for community based treatment.

Becca Bill Program

The Becca Bill programs fall into 3 categories: At-Risk Youth; Children in Need of Services (CHINS); and Truancy. Court intervention, case planning, and monitoring services are provided.

Victim Restoration Program

Provides advocacy services to victims of juvenile crime including Court process information, victim impact statements, restitution claim processing and collection, and general support.

Chemical Dependency Disposition Alternative (CDDA)

E3SHB 3900 allows for the evaluation of chemically abusing youth to be considered for a disposition alternative that allows judges to order treatment instead of confinement.

Parks & Recreation Department

Whatcom County Parks and Recreation operates eight senior centers, seven developed parks, a rifle range, a cultural arts program, an outdoor recreation program and serves as a tourist information center.

FTE's for this department

Year	2001	2002	2003	*2004	*2005	*2006	<i>*budget</i>
FTE	33.55	33.55	33.55	33.55	33.55	33.55	

The chart below shows the organizational structure for 2005 only.

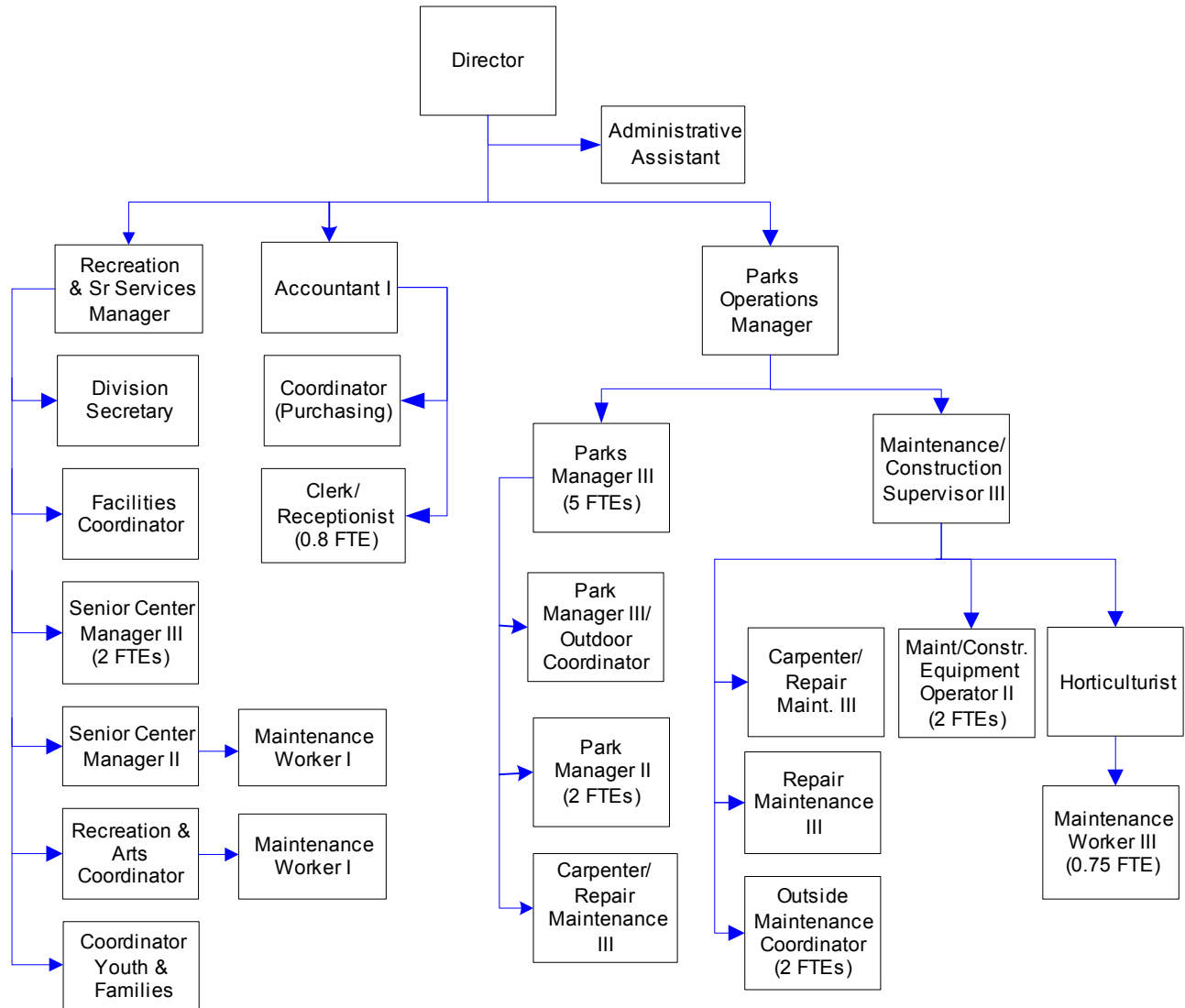

Mission & Objectives

Mission

Enrich the quality of life for the community and preserve the natural and cultural heritage of Whatcom County through provision of outstanding parks, trails, open space, natural areas, recreational activities and senior services.

Objectives

- Develop and maintain partnerships in the community to maximize use of resources and build support for county sponsored park and recreation facilities and programs.
- When feasible, recover maintenance and operating costs of programs and facilities through user fees and rent revenues.
- Complete the revision, approval and IAC certification of the Whatcom County Comprehensive Parks and Recreation Open Space Plan by December 31, 2005.
- To improve customer service, provide on-line program registration and facility calendaring by July 1, 2005.
- During 2005, revise departmental policies and procedures for special events.

Parks

- Operate and maintain park facilities for county residents and visitors including: Deming Homestead Eagle Park, Hovander Homestead Park and Tennant Lake Interpretive Center, Lighthouse Marine Park, Pine and Cedar Lakes, Plantation Rifle Range, Samish Park, Semiahmoo Park, Silver Lake Park, Squires Lake Park, and Sunset Farm Equestrian Center. An estimated 636,900 people will visit Whatcom County parks (including trails; not including Roeder Home or senior centers) in 2005 and in 2006.
- Operate and maintain approximately 50 miles of improved trails for hikers, bicyclists and horseback riders throughout the county, some of which are located in the park sites listed above and also including: Canyon Lake Creek Community Forest, Chuckanut Mountain, Hertz Trail/North Lake Whatcom Park, Interurban Trail, Monument Park, Stimpson Family Nature Reserve, and Teddy Bear Cove.
- Mark boundaries of all surveyed park properties (2005 - 2006).
- Install trail counters at selected trails to begin gathering accurate use figures (2005).
- Install new and replace flood-damaged bridges at Canyon Lake Creek Community Forest with funding from Whatcom Land Trust and FEMA (2005).
- Develop small gravel parking lot at East Acme Farm to allow better access for walking to existing gravel service road (2005).
- Clear and brush the Glacier to Maple Falls

Objectives continued

- Trail corridor where access allows, and research permitting requirements and costs for bridge development (2005 - 2006).
- Resurface the walkway in the Fragrance Garden at Tennant Lake Interpretive Center (2005).
 - Harden trail along dike at Hovander Homestead Park in coordination with work proposed by River & Flood (2005).
 - Eliminate creosote pilings in the bridge crossing the slough at Hovander Homestead Park (2006).
 - Remove dilapidated building at shoreline of Lighthouse Marine Park (2006).
 - Develop trails and install signage at Olsen Property (2006).
 - Make required improvements to Plantation Range water system (2005).
 - Top-coat roof at pistol range at Plantation Range (2005).
 - Repair and/or resurface road to Plantation Range (2005 - 2006).
 - Replace the Roeder Home roof (2006).
 - Dig a well or make other required improvements to Samish Park water system (2005).
 - Winterize old office building at Semiahmoo Park (2005).
 - Make landscape improvements at Semiahmoo Park using native plants (2005).
 - Reroof old bunkhouse at Semiahmoo Park (2006).
 - Renovate the shower building at Silver Lake Park (2005).

- Install another prefab vault toilet at Silver Lake Park, continuing the replacement of old wooden outhouses (2006).
- Provide access to South Bay Drive property (formerly Zobrist rental) for picnicking and other low impact recreation (2006).

Recreation

- Offer county residents the opportunity to participate in cultural arts classes and activities. A total of 133 classes will be offered to encourage creativity, skill development, self-esteem and safety. A total of 900 people will participate.
- The historic Roeder Home is available for various arts & crafts and cultural events and private rentals. Rental revenues help offset the cost of operations. An estimated 34,000 people will visit the Roeder Home in 2005.
- Provide 170 different outdoor recreation classes and activities that provide county residents an opportunity to experience the Pacific Northwest. Students learn the skills needed to safely participate in a wide variety of outdoor activities. Approximately 1,500 people will spend 12,500 hours of time involved in activities sponsored by the Outdoor Program. Class revenue helps offset the cost of operating the program.
- Provide 155 outdoor classes to Whatcom County youth and their family members. The new program title is Youth and Family Adventure Program to replace the Teen Adventure Program title. This program encourages self-confidence, making healthy lifestyle choices, building positive peer relationships and learning leadership skills.

The program works closely with local school districts, and other agencies serving youth, in the development of program activities. An estimated 1,500 people will spend 9,200 hours participating in these classes and activities.

- Survey participants in the Cultural Arts, Outdoor, and Youth and Family Adventure Programs to gather suggestions for improvement and gauge the level of satisfaction.

Senior Services

- Operate four full service Senior/Community Centers in Bellingham, Blaine, Ferndale and Lynden attracting an estimated 159,210 annual visitors. These facilities are located in the Whatcom County communities with the largest senior citizen populations and are open 5-6 days per week. A full range of human, recreation and support services are provided.
- Operate four Senior/Community Centers in Everson, Point Roberts, Sumas, and Welcome Valley attracting an estimated 11,655 annual visitors. These centers serve communities with smaller senior citizen populations and are open 1-3 days per week. These centers have a drop-in focus around the noon meal program.
- Coordinate efforts with various community groups to make Senior/Community Centers available for public use during evening and weekend hours when senior citizen activities are not scheduled. Estimated community use for the year is 36,975 visitors. Examples of community users include government agencies, private non-profit organizations, health and support groups, arts and performance groups, service organizations, church and religious organizations, and business/commercial users.
- Maintain operating partnerships with the Whatcom County Council on Aging and other local governments, non-profit agencies and service organizations to expand service options for senior citizens who participate in Senior/Community Center activities. The Council on Aging offers meal programs and other human services that enhance the services provided at each center.
- Recruit, train and supervise a corps of volunteers to support program activities at the Senior/Community Centers. An estimated 3,750 volunteers will provide 40,000 hours of service for the year. Volunteer support enables Senior Services to maintain, and in some cases expand, service levels without additional personnel resources.
- Conduct an annual survey in the Senior/Community Center facilities to gather suggestions for improvement and gauge the level of satisfaction among people who participate.

Expenditure Trends

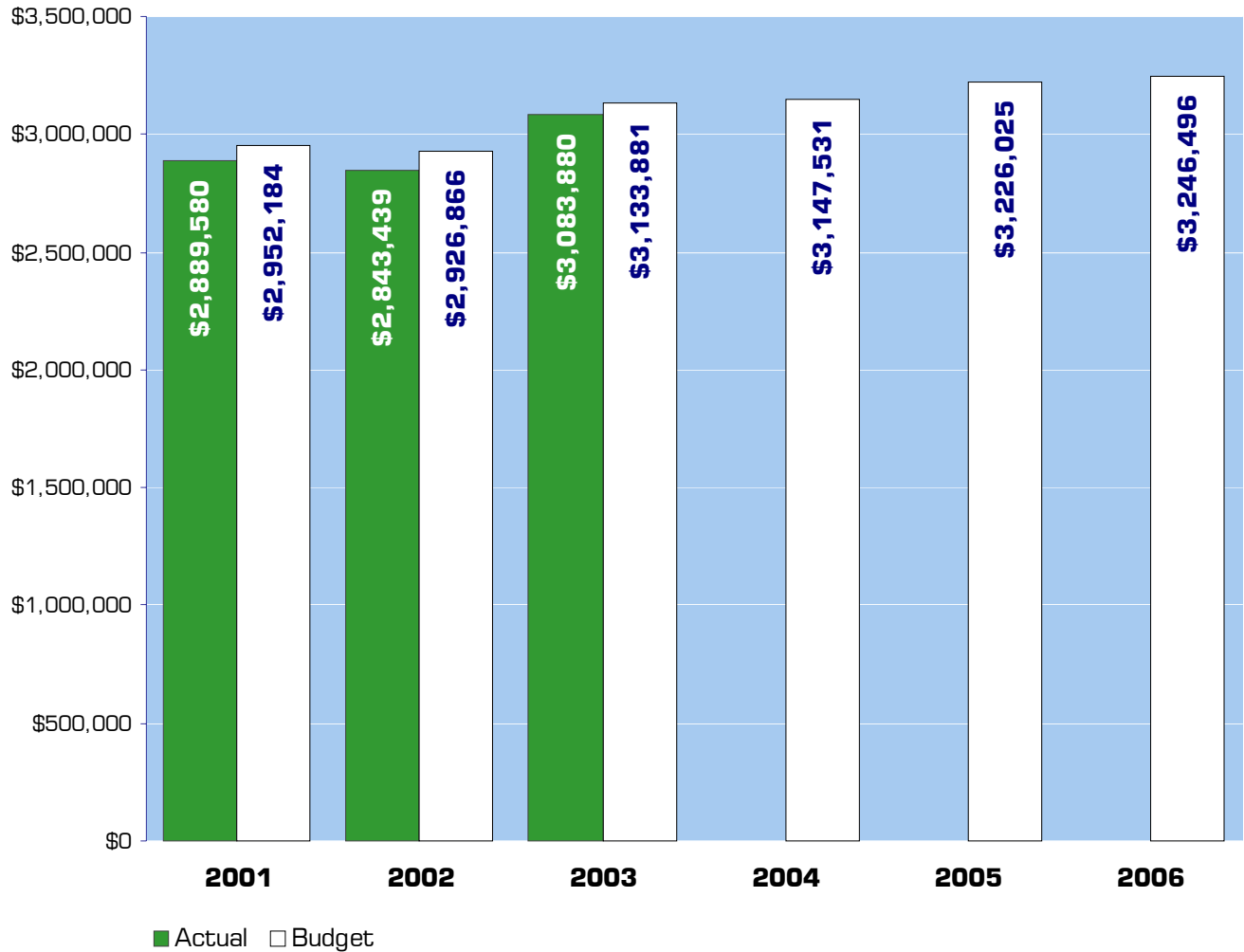

NOTE: Capital expenditures and interfund operating transfers are not shown to more accurately reflect ongoing operational costs.

2005-2006 Budget by Program

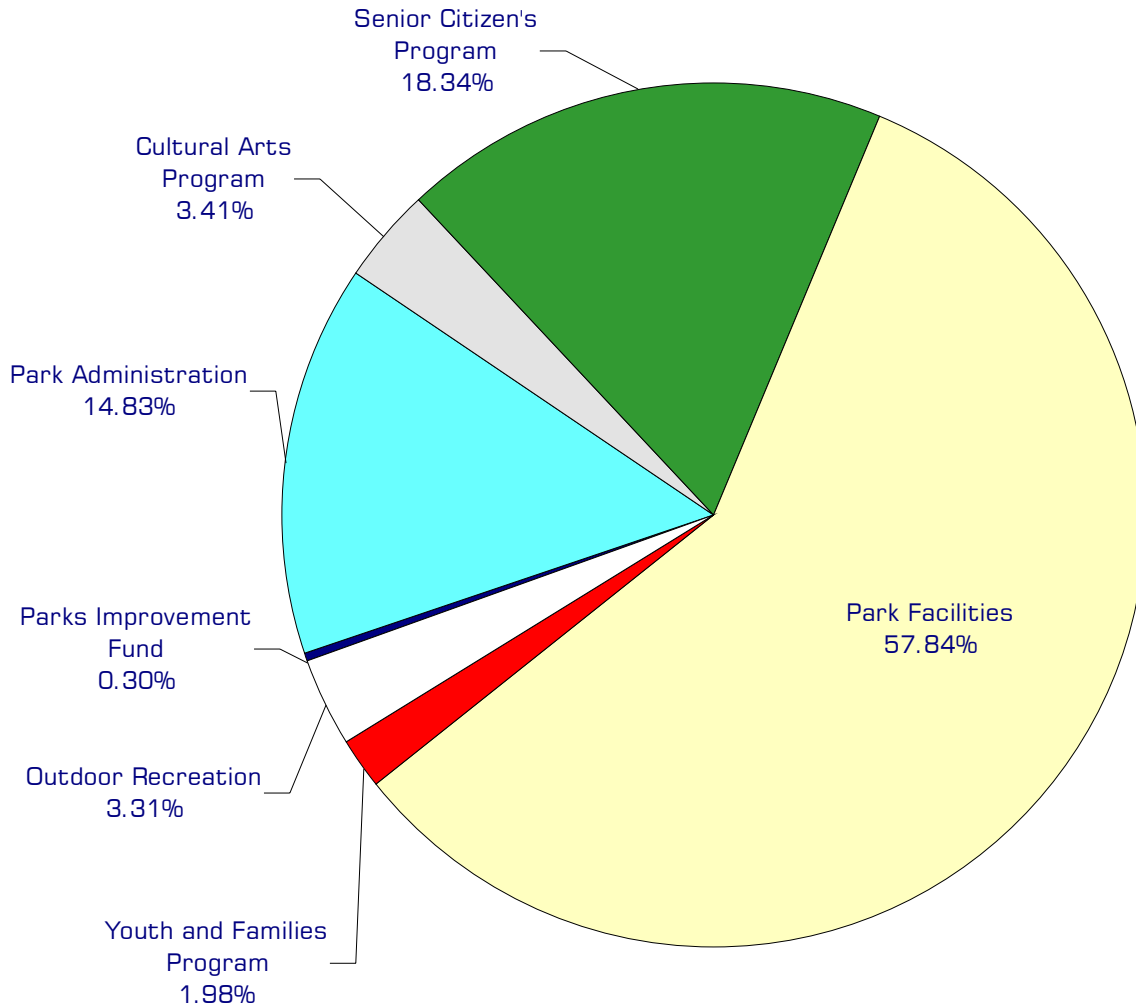

NOTE: Capital expenditures are not shown to more accurately reflect ongoing operational costs.

Program Summary

	Actual 2001	Actual 2002	Actual 2003	Budget 2004	Budget 2005	Budget 2006
OPERATIONS						
General Fund						
6000 Park Administration	415,778	404,686	406,033	447,993	475,489	484,603
6001 Cultural Arts Program	108,274	109,896	114,290	108,588	111,238	109,326
6002 Senior Citizen's Program	537,724	558,748	614,300	580,561	591,863	594,899
6003 Park Facilities	1,586,484	1,571,095	1,746,190	1,761,827	1,858,228	1,885,458
6005 Youth and Families Program	68,677	66,133	73,774	86,284	63,160	64,754
6009 Black Mtn Forestry Center	10,202	5,034	-	-	-	-
6010 Pine/ Cedar Lk Trail	24,678	-	-	-	-	-
6015 Outdoor Recreation	137,763	126,375	129,293	149,778	106,633	107,456
Parks Improvement Fund	-	1,472	-	12,500	19,414	-
Total Park Operations	2,889,580	2,843,439	3,083,880	3,147,531	3,226,025	3,246,496
CAPITAL						
General Fund						
6000 Park Administration	13,369	2,851	-	-	-	-
6003 Park Facilities	39,057	31,508	42,595	43,085	33,200	-
6004 Rifle Range	-	-	-	72,500	-	-
6010 Pine/ Cedar Lk Trail	1,734	-	-	-	-	-
6015 Outdoor Recreation	-	-	1,912	-	-	-
Parks Improvement Fund	33,545	-	-	20,000	20,000	-
Total Park Capital	87,705	34,359	44,507	135,585	53,200	-
TRANSFERS						
6000 Park Administration	2,869	-	-	-	-	-
6001 Cultural Arts Program	537	-	-	-	-	-
6002 Senior Citizen's Program	3,760	-	-	-	-	-
6003 Park Facilities	35,562	5,000	3,500	-	-	-
6005 Youth and Families Program	379	-	-	-	-	-
6015 Outdoor Recreation	567	9,000	-	-	-	-
Total Park Transfers	43,674	14,000	3,500	-	-	-
TOTAL PARK	3,020,959	2,891,798	3,131,887	3,283,116	3,279,225	3,246,496
<i>Percent Change from Previous Year</i>	<i>4.7%</i>	<i>-4.3%</i>	<i>8.3%</i>	<i>4.8%</i>	<i>-0.1%</i>	<i>-1.0%</i>

2005-2006 Funding Sources

	2005	2006
Charges for Service	337,857	337,857
Miscellaneous Revenue	23,798	14,168
Rental Income	340,156	340,156
General Fund	2,460,409	2,554,315
Contributions	45,391	0
*Fund Balance	18,414	0
Total Funding	3,226,025	3,246,496

Fund Balance

The 2005-2006 budget provides for spending down \$18,414 of the Park Improvement's unreserved fund balance.

Charges for Service & Fees

Recreational fees such as rifle range and boat launch fees, and program instruction fees.

Miscellaneous Revenue

Small amounts of revenues not otherwise classified.

Rental Income

Rental of cabins, campsites, boats and various parks facilities and properties.

General Fund

Undedicated General Fund resources.

Contributions

Donations from Alcoa and the Whatcom Parks & Recreation Foundation and Whatcom County Council on Aging in support of the Youth and Family Program, the Tennant Lake Interpretive Center and the Bellingham Senior Center.

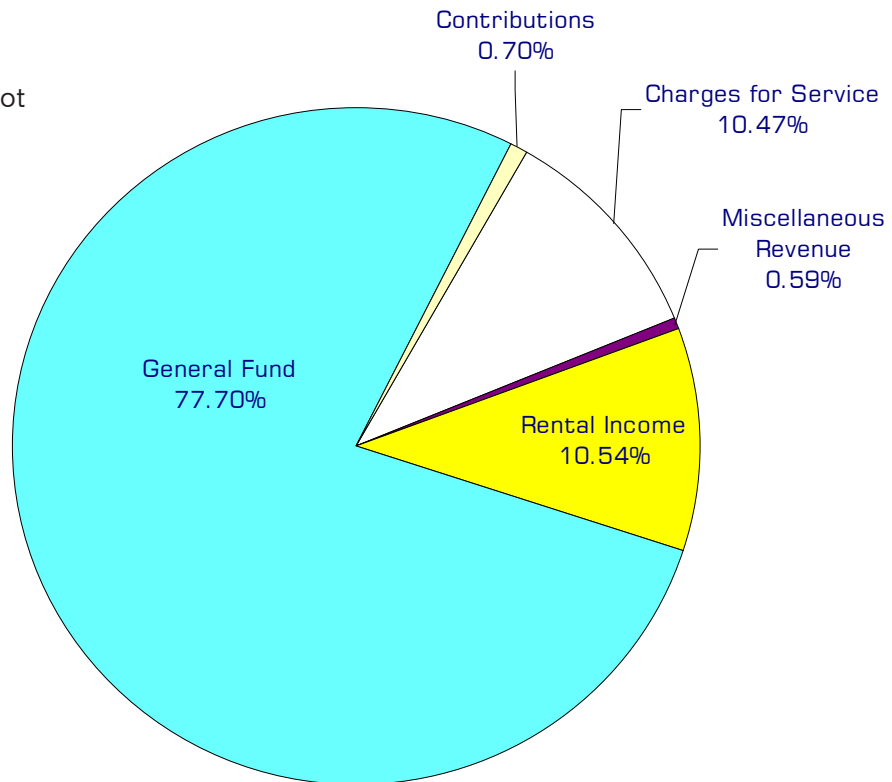

*Fund balance is not included in above chart.

Performance / Activity Measures

	Actual 2001	Actual 2002	Actual 2003	Projected 2004	Projected 2005	Projected 2006
Attendance						
Hovander Homestead Park	141,494	184,957	148,986	125,000	140,000	140,000
Tennant Lake Interpretive Center	47,224	121,154	83,009	65,000	70,000	70,000
Lighthouse Marine Park	93,819	83,041	91,511	90,000	90,000	90,000
Plantation Rifle Range	17,295	17,001	16,824	17,600	17,600	17,600
Samish Park	32,510	45,569	42,528	43,000	43,000	43,000
Semiahmoo Park	22,300	22,300	22,300	22,300	23,000	24,000
Silver Lake Park	102,187	83,536	94,405	96,000	96,000	96,000
Squires Lake Park	17,345	17,400	17,400	17,400	17,400	17,400
Chuckanut Mountain Trails	9,333	9,400	9,400	9,400	9,400	9,400
Interurban Trail	60,891	60,900	60,900	60,900	60,900	60,900
Interurban Trail-Teddy Bear Cove	17,786	17,800	17,800	17,800	17,800	17,800
Hertz Lake Whatcom Trail	21,602	21,700	25,000	25,000	25,000	25,000
Pine and Cedar Lakes Trail	8,474	8,500	8,500	8,500	8,500	8,500
Canyon Lake Creek (7/31/01)	3,000	5,000	5,000	5,000	6,000	6,000
Deming Homestead Eagle Park (3/02)		6,000	8,000	8,000	8,000	8,000
Stimpson Family Nature Reserve (6/03)			1,500	5,000	5,000	5,000
Total Parks Attendance	579,290	614,258	653,063	615,900	636,900	636,900
Total Parks, Recreation, Senior & Community Attendance	773,531	812,144	894,421	859,984	881,090	881,090
Work Orders	325	299	282	325	325	325
<i>Senior Services</i>						
Senior Attendance						
Bellingham Senior Activity Center	51,048	57,128	65,579	70,184	70,185	70,185
Blaine Community/Senior Center	21,699	26,706	31,446	32,096	32,100	32,100
Everson Senior Center	2,541	2,166	2,700	3,225	3,225	3,225
Ferndale Community Center	21,698	21,613	22,737	21,746	21,750	21,750
Lynden Community Center	35,880	35,878	35,749	35,174	35,175	35,175
Point Robert Community Center	2,184	2,846	3,042	3,916	4,000	4,000
Sumas Community Center	3,502	3,104	3,466	3,212	3,215	3,215
Welcome Senior Center	1,249	1,092	1,041	1,216	1,215	1,215
Total Senior Attendance	139,801	150,533	165,760	170,767	170,865	170,865

continued on next page

Performance / Activity Measures continued

	Actual 2001	Actual 2002	Actual 2003	Projected 2004	Projected 2005	Projected 2006
Community Attendance						
Bellingham Senior Activity Center	13,552	15,930	13,733	13,588	13,500	13,500
Blaine Community/Senior Center	2,070	1,275	2,281	2,676	2,500	2,500
Ferndale Community Center	7,870	3,355	4,800	3,044	3,250	3,250
Lynden Community Center	25,254	24,028	19,036	16,670	16,750	16,750
Sumas Community Center	1,458	1,957	766	846	850	850
Welcome Senior Center	386	345	170	116	125	125
Total Community Attendance	50,590	46,890	40,786	36,940	36,975	36,975
Senior Center Volunteer Hours	35,559	37,890	39,797	40,268	40,000	40,000
Senior Volunteers	3,076	3,264	3,602	3,866	3,750	3,750
Dollar Value of Volunteer Services	\$ 238,956	\$ 261,441	\$ 278,579	\$ 288,319	\$ 286,400	\$ 286,400
<i>Youth and Family Adventure Program (Formerly TAP)</i>						
Revenue	\$ 20,131	\$ 17,757	\$ 18,500	\$ 19,500	\$ 32,500	\$ 32,500
Participatory hours	12,769	11,489	9,000	8,966	9,200	9,200
Participants	1,809	1,666	800	1,028	850	850
Classes offered	141	155	105	155	155	155

Expenditures Summary

	Actual 2001	Actual 2002	Actual 2003	Budget 2004	Budget 2005	Budget 2006
PARK FUND						
6000 Park Administration						
Salaries & Wages	215,351	221,004	213,428	230,153	253,075	249,842
Benefits	54,657	54,636	54,180	65,345	76,517	84,525
Supplies	12,424	6,255	8,549	14,232	14,232	14,232
Other Services & Charges	133,297	122,791	129,876	138,203	131,605	135,944
Intergov Services & Charge	49	-	-	60	60	60
Capital Outlay	13,369	2,851	-	-	-	-
Operating Transfers	2,869	-	-	-	-	-
<i>Total Administration</i>	<i>432,016</i>	<i>407,537</i>	<i>406,033</i>	<i>447,993</i>	<i>475,489</i>	<i>484,603</i>
<i>Percent Change from Previous Year</i>	<i>4.7%</i>	<i>-5.7%</i>	<i>-0.4%</i>	<i>10.3%</i>	<i>6.1%</i>	<i>1.9%</i>
6001 Cultural Arts Program						
Salaries & Wages	64,287	65,717	68,850	69,992	70,958	67,438
Benefits	12,694	12,685	14,195	15,050	16,734	18,342
Supplies	11,308	10,298	10,581	7,203	7,203	7,203
Other Services & Charges	19,985	21,196	20,664	16,343	16,343	16,343
Intergov Services & Charge	-	-	-	-	-	-
Operating Transfers	537	-	-	-	-	-
<i>Total Cultural Arts Program</i>	<i>108,811</i>	<i>109,896</i>	<i>114,290</i>	<i>108,588</i>	<i>111,238</i>	<i>109,326</i>
<i>Percent Change from Previous Year</i>	<i>4.7%</i>	<i>1.0%</i>	<i>4.0%</i>	<i>-5.0%</i>	<i>2.4%</i>	<i>-1.7%</i>
6002 Senior Citizen's Program						
Salaries & Wages	336,369	356,183	371,615	343,075	343,862	343,431
Benefits	82,685	75,548	85,741	92,394	103,983	115,366
Supplies	27,114	30,155	29,678	33,877	32,550	32,550
Other Services & Charges	91,556	96,706	127,266	111,115	111,368	103,452
Intergov Services & Charge	-	156	-	100	100	100
Operating Transfers	3,760	-	-	-	-	-
<i>Total Senior Citizen's Program</i>	<i>541,484</i>	<i>558,748</i>	<i>614,300</i>	<i>580,561</i>	<i>591,863</i>	<i>594,899</i>
<i>Percent Change from Previous Year</i>	<i>0.0%</i>	<i>3.2%</i>	<i>9.9%</i>	<i>-5.5%</i>	<i>1.9%</i>	<i>0.5%</i>
6003 Park Facilities						
Salaries & Wages	865,855	858,750	975,908	1,022,318	1,066,644	1,062,745
Benefits	239,557	229,842	251,703	265,116	303,890	335,019
Supplies	186,266	170,592	180,146	156,987	164,849	164,849
Other Services & Charges	291,990	308,831	335,809	314,106	319,545	319,545
Intergov Services & Charge	2,816	3,080	2,624	3,300	3,300	3,300
Capital Outlay	39,057	31,508	42,595	43,085	33,200	-
Operating Transfers	10,077	-	-	-	-	-
Residual Equity Transfers	25,485	5,000	3,500	-	-	-
<i>Total Park Facilities</i>	<i>1,661,103</i>	<i>1,607,603</i>	<i>1,792,285</i>	<i>1,804,912</i>	<i>1,891,428</i>	<i>1,885,458</i>
<i>Percent Change from Previous Year</i>	<i>4.6%</i>	<i>-3.2%</i>	<i>11.5%</i>	<i>0.7%</i>	<i>4.8%</i>	<i>-0.3%</i>

continued on next page

Expenditures Summary continued

	Actual 2001	Actual 2002	Actual 2003	Budget 2004	Budget 2005	Budget 2006
6005 Youth and Families Program						
Salaries & Wages	33,968	36,823	40,244	54,032	48,648	48,708
Benefits	10,840	10,753	11,864	13,814	14,512	16,046
Supplies	9,251	5,949	6,368	7,495	-	-
Other Services & Charges	14,618	12,608	15,298	10,943	-	-
Operating Transfers	379	-	-	-	-	-
<i>Total Youth and Families Program</i>	<i>69,056</i>	<i>66,133</i>	<i>73,774</i>	<i>86,284</i>	<i>63,160</i>	<i>64,754</i>
<i>Percent Change from Previous Year</i>	<i>41.4%</i>	<i>-4.2%</i>	<i>11.6%</i>	<i>17.0%</i>	<i>-26.8%</i>	<i>2.5%</i>
6009 Black Mtn Forestry Ctr Project						
Other Services & Charge	10,202	5,034	-	-	-	-
<i>Tot Blk Mtn Forestry Ctr Project</i>	<i>10,202</i>	<i>5,034</i>	<i>-</i>	<i>-</i>	<i>-</i>	<i>-</i>
<i>Percent Change from Previous Year</i>	<i>-55.8%</i>	<i>-50.7%</i>	<i>-100.0%</i>	<i>0.0%</i>	<i>0.0%</i>	<i>0.0%</i>
6010 Pine/Cedar Lk Trail						
Supplies	13,380	-	-	-	-	-
Other Services & Charge	11,298	-	-	-	-	-
Capital Outlay	1,734	-	-	-	-	-
<i>Total Pine/Cedar Lk Trail</i>	<i>26,412</i>	<i>-</i>	<i>-</i>	<i>-</i>	<i>-</i>	<i>-</i>
<i>Percent Change from Previous Year</i>	<i>0.0%</i>	<i>-100.0%</i>	<i>0.0%</i>	<i>0.0%</i>	<i>0.0%</i>	<i>0.0%</i>
6015 Outdoor Recreation						
Salaries & Wages	68,695	67,127	66,105	70,174	34,476	34,476
Benefits	14,670	14,261	15,220	15,607	8,560	9,383
Supplies	14,434	14,242	6,592	10,250	10,250	10,250
Other Services & Charges	39,964	30,745	41,376	53,747	53,347	53,347
Capital Outlay	-	-	1,912	-	-	-
Operating Transfers	567	-	-	-	-	-
Residual Equity Transfers	-	9,000	-	-	-	-
<i>Total Outdoor Recreation</i>	<i>138,330</i>	<i>135,375</i>	<i>131,205</i>	<i>149,778</i>	<i>106,633</i>	<i>107,456</i>
<i>Percent Change from Previous Year</i>	<i>9.7%</i>	<i>-2.1%</i>	<i>-3.1%</i>	<i>14.2%</i>	<i>-28.8%</i>	<i>0.8%</i>
6004 Rifle Range						
Capital Outlay	-	-	-	72,500	-	-
<i>Total Rifle Range</i>	<i>-</i>	<i>-</i>	<i>-</i>	<i>72,500</i>	<i>-</i>	<i>-</i>
<i>Percent Change from Previous Year</i>	<i>0.0%</i>	<i>0.0%</i>	<i>0.0%</i>	<i>0.0%</i>	<i>-100.0%</i>	<i>0.0%</i>
<i>Total Park Fund</i>	<i>2,987,414</i>	<i>2,890,326</i>	<i>3,131,887</i>	<i>3,250,616</i>	<i>3,239,811</i>	<i>3,246,496</i>
<i>Percent Change from Previous Year</i>	<i>5.0%</i>	<i>-3.2%</i>	<i>8.4%</i>	<i>3.8%</i>	<i>-0.3%</i>	<i>0.2%</i>

Expenditures Summary continued

	Actual 2001	Actual 2002	Actual 2003	Budget 2004	Budget 2005	Budget 2006
PARK IMPROVEMENT FUND						
33000 Park Improvements						
Supplies	-	-	-	11,000	10,500	-
Other Services & Charges	-	1,472	-	1,500	8,914	-
Capital Outlay	33,545	-	-	20,000	20,000	-
<i>Total Park Improvements</i>	<u>33,545</u>	<u>1,472</u>	<u>-</u>	<u>32,500</u>	<u>39,414</u>	<u>-</u>
<i>Percent Change from Previous Year</i>	-19.8%	-95.6%	-100.0%	0.0%	21.3%	-100.0%
TOTAL PARK	<u>3,020,959</u>	<u>2,891,798</u>	<u>3,131,887</u>	<u>3,283,116</u>	<u>3,279,225</u>	<u>3,246,496</u>
<i>Percent Change from Previous Year</i>	4.7%	-4.3%	8.3%	4.8%	-0.1%	-1.0%

Services

Cultural Arts and Roeder Home

Provide cultural arts classes and activities to citizens of Whatcom County. Public use of the historic Roeder Home for various community use activities.

Senior Services - Drop-In Centers

Recreation, education and human services for the elderly and other members of the community in the four smaller Whatcom County population centers.

Youth & Family Adventure Program

Outdoor recreation, life skills and interpretive programs for Whatcom County Youth and Family.

Senior Services - Full Service Centers

Recreation, education and human services for the elderly and other members of the community living in Whatcom County.

Parks

Provide maintenance and operations of 10 developed parks, trails, additional properties owned by the department, maintenance of 3 senior activity centers, and facilitate community events in parks.

Planning & Development Services

Divisions and their services are: Building Services (construction permits of all kinds, life safety code enforcement, plan check/inspection, burn permits, fire safety inspections); Land Use Services (pre-construction zoning, shorelines, SEPA, land use, critical areas, subdivisions, land use code enforcement); Planning Services (long range planning, comprehensive plans, growth management, water resources).

FTE's for this department

Year	2001	2002	2003	*2004	*2005	*2006
FTE	47.35	48.35	49.35	57.00	59.00	54.00

**budget*

The chart below shows the organizational structure for 2005 only.

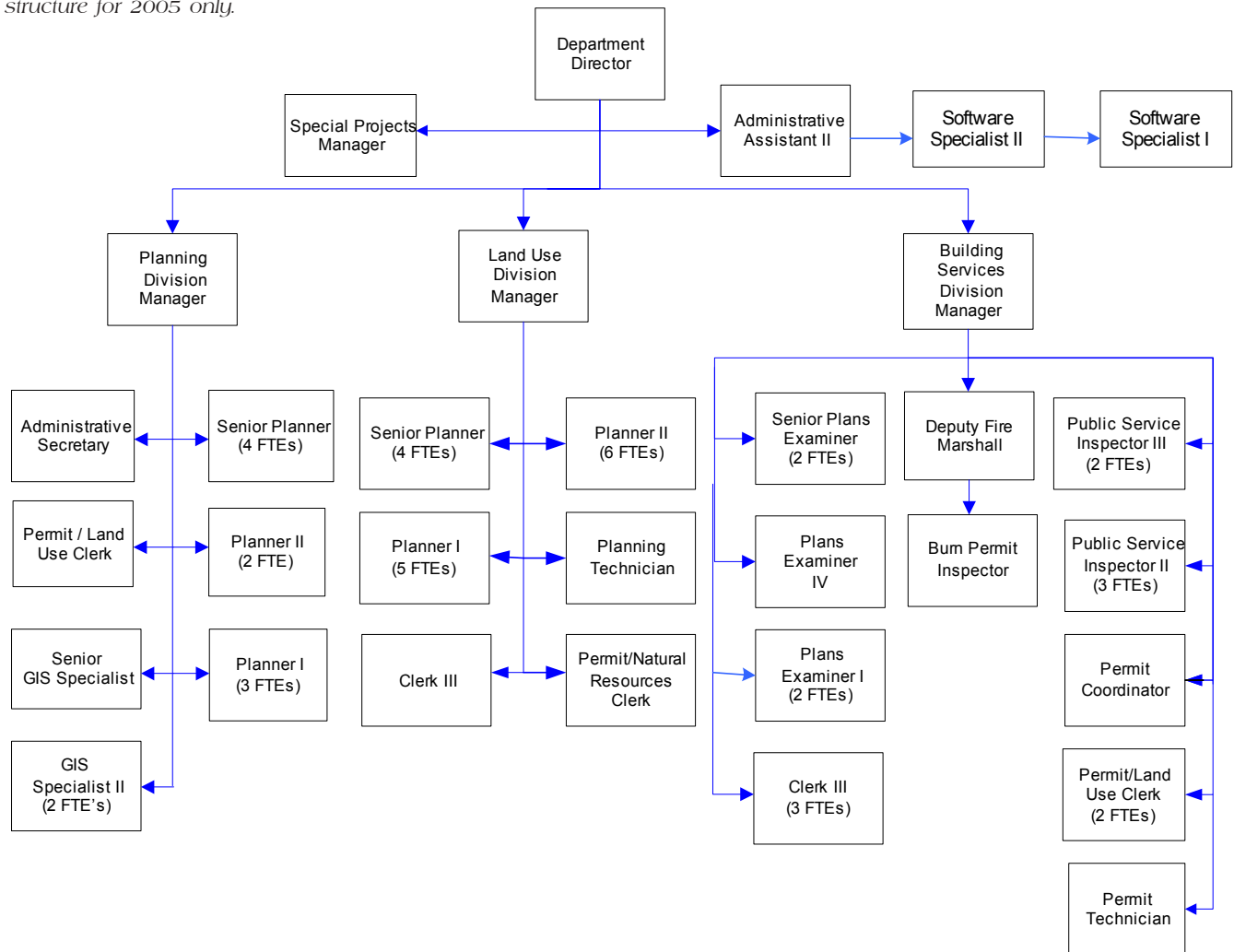

Mission & Objectives

Mission

Building Services

Provide excellent customer service while administering laws, codes and policies that promote better building construction and greater safety for our community.

Land Use

Assist the public and other agencies in the implementation of the Comprehensive Plan, county policies and regulations including the following: subdivision, shoreline, environmental review, zoning codes, and natural resource protection. Perform these reviews in conjunction with Federal, State and County regulations as they relate to the physical and economic health of our county.

Planning

Enhance and protect the quality of life and comply with state and federal mandates by preparing land use, transportation and facility plans, policies and regulations to guide and regulate land development within Whatcom County. Provide information and assistance to advisory boards, legislative bodies and the County Executive regarding land use, natural resources, and economic development issues.

Objectives

Administration

- Seek greater public input from the Whatcom County community. Create more opportunities to interact directly with the community through sub-area planning efforts, participation in local community events and attendance at community forums. Learn from the past, offer visions and choices for the future, and recommend policies and actions that will promote and achieve the following:
 - Involve the citizens in transportation planning through the six-year transportation plan.
 - Involve county staff, citizens and businesses in understanding Land Use and Transportation linkages.
 - Involve citizens, businesses, and institutions in economic development planning and coordination.
- Create a dialog with the community regarding emerging trends.
- Provide accurate and timely service to the public using available resources by:
 - Ensuring all facets of the permit process are responsive to individual customer needs.
 - Maintaining a customer service focus by shifting employees to "service" our permit needs during peak periods of the construction and permitting seasons.
 - Supporting front counter improvements and One Stop Shop efforts.
 - Supporting Skills Enhancement Programs for the front counter staff.

Objectives continued

- Involve citizens in Whatcom County decisions by:
 - Creating a sustained effort at providing public information to sub areas of the county
 - Developing a higher standard of public outreach for all County/capital expenditure programs.
 - Developing an annual report to the Planning Commission per state law on development trends in the county.
 - Developing an annual report to the Planning Commission per state law on shorelines.
- Maintain and improve upon high levels of customer service by:
 - Developing annual training on customer service.
 - Developing measures to ascertain customer satisfaction.
 - Return to internal training efforts to build skills rapidly.
- Ensure compliance with federal and state laws including:
 - Growth Management Act RCW 36.70A, compliance with the annual update provisions, compliance with the seven-year update provisions.
 - Shoreline Management Act RCW 90.58, compliance with the updating provisions.
 - Watershed Management Act 90.82.
- Provide for greater harmony between the natural, built and human environments by:
 - Encouraging a high level of interdepartmental cooperation.
 - Encouraging ongoing dialogue between Whatcom County cities and the county.
 - Coordinating natural resource based issues consistent with the county's Comprehensive Plan and charter including coordination in Lake Whatcom, Lake Samish, Drayton Harbor and Birch Bay watersheds for special district considerations (such as shellfish).
 - Promoting adequate parks, open spaces, recreation and cultural resources.
 - Implementing the Whatcom County Comprehensive Plan for Open Space Planning Goals and Objectives through PDR/TDR/Covenants and other means.
 - Creating wetland banking opportunities.
- Coordination/Project Review:
 - Working with the Bicycle and Pedestrian Advisory Committee coordinating bike/pedestrian and transportation improvements.
 - Working with the Parks and Recreation and Open Space Planning group and coordinating associated improvements.

Objectives continued

- Support a healthy economic base by:
 - Coordinating implementation of the Whatcom County Community Economic Development Strategy (CEDS).
 - Ensuring that Whatcom County has an adequate land supply to encourage appropriate economic development.
 - Promoting the economic health of natural resource based industries in the county.
 - Supporting rural based business needs.
 - Promoting conservation of the area's natural resources including shorelines and critical areas.
 - Implementing Competitiveness Council recommendations.
- Preserve and enhance unincorporated county neighborhoods and housing choices by:
 - Working with the Columbia Valley neighborhood to ensure safety and health codes are being followed.
 - Coordinating more closely with rural housing providers in rural sub-area planning districts of the county including: the Foothills; Birch Bay; Point Roberts; Lummi Island.
 - Working with Foothills to develop a rural employment and training center within the context of a small town planning effort.
- Seek creative solutions to regional planning problems/opportunities by:
 - Participating on the Council of Government's Regional Transportation Planning Organization.
 - Continuing to coordinate with Whatcom County cities.

- Prepare and administer fiscally responsible budgets by:
 - Augmenting the existing budget through grants.
 - Developing and testing new county programs on a small/pilot project scale.
 - Improving coordination efforts between federal, state and Whatcom County agencies to deliver services to the community.
 - Accurately evaluating community-wide trends through the assessment of census data, economic data building permit data and other relevant information as it becomes available.

Building Services

- Provide required services (including enforcement and plan checks) with courtesy, compassion and professionalism.
- Maintain high level of customer service by:
 - Monitoring counter and phone reception for customer service and cash receipting procedures.
 - Monitoring and tracking permits and providing backup of plan check during times of heavy workloads.
- Develop written policies and procedures for the functions of the Building Services Division, including plan check, front counter, inspections, phone reception, and fire reviews.
- Provide accurate and timely service to the public using available resources and temporary extra help when demand exceeds resource.
- Maintain residential plan review turnaround at 4 weeks or under.

Objectives continued

- Maintain building inspection appointments with 24 hour notice.
- Process small commercial plans within 8 weeks or less of submittal.
- Process large commercial plans within 12 weeks of submittal.
- Continue joint arson investigation program with Sheriff's Office.
- Continue interagency partnerships for benefit of community and state (i.e., DNR & Emergency Response Team; State Arson Board, Region 3 Fire Investigation Task Force).
- Maintain open burning program with NWAPA.
- Update Building Services including Fire Marshall information on website.
- Implement "One Stop" in 2005 and monitor "One Stop" in 2006.
- Continue to provide training opportunities consistent with Skills Enhancement Program for PDS as developed with the Human Resources Office.
- Finalize the comprehensive Compliance Ordinance to ensure consistent and effective enforcement of the Universal Building Code, Land Use Regulation and Natural Resources Codes.
- Update Land Use web pages on regular basis to assist public in understanding processes and regulations they must operate within.

Land Use

- Provide and maintain informational brochures for each area and service provided by the Land Use Division. The brochures will explain the basic services and review offered by the Land Use Division and the Natural Resource Section.
 - Establish the Natural Resource Section, which will perform all Natural Resource reviews including: Wetlands, Lake and Stream Management, Aquifer Recharge Area review, Surface Mining and Geological Hazard Area Reviews (including alluvial fan hazard areas), Agricultural Nutrient Enforcement, and State Environmental Policy Act Reviews and Determinations.
 - Complete zoning and environmental reviews within three days of a completed submittal of the required information.
- Planning**
- Comply with the Growth Management Act.
 - Complete mandated update of the Whatcom County Shoreline Management Program.
 - Coordinate Capital Facilities planning and Comprehensive Economic Development Strategy project list.
 - Perform mandated current planning functions including review of rezones, open space, annexation requests, zoning text amendments, comprehensive plan amendments, forest practice applications, and public information on land use questions.
 - Enhance GIS resources to increase interdepartmental communication and promote GIS services with other jurisdictions, development community and with citizens.
 - Complete the update of two subarea plans.
 - Work with the community groups and advisory boards to implement high priority action items in the Whatcom County Comprehensive Plan.

Expenditure Trends

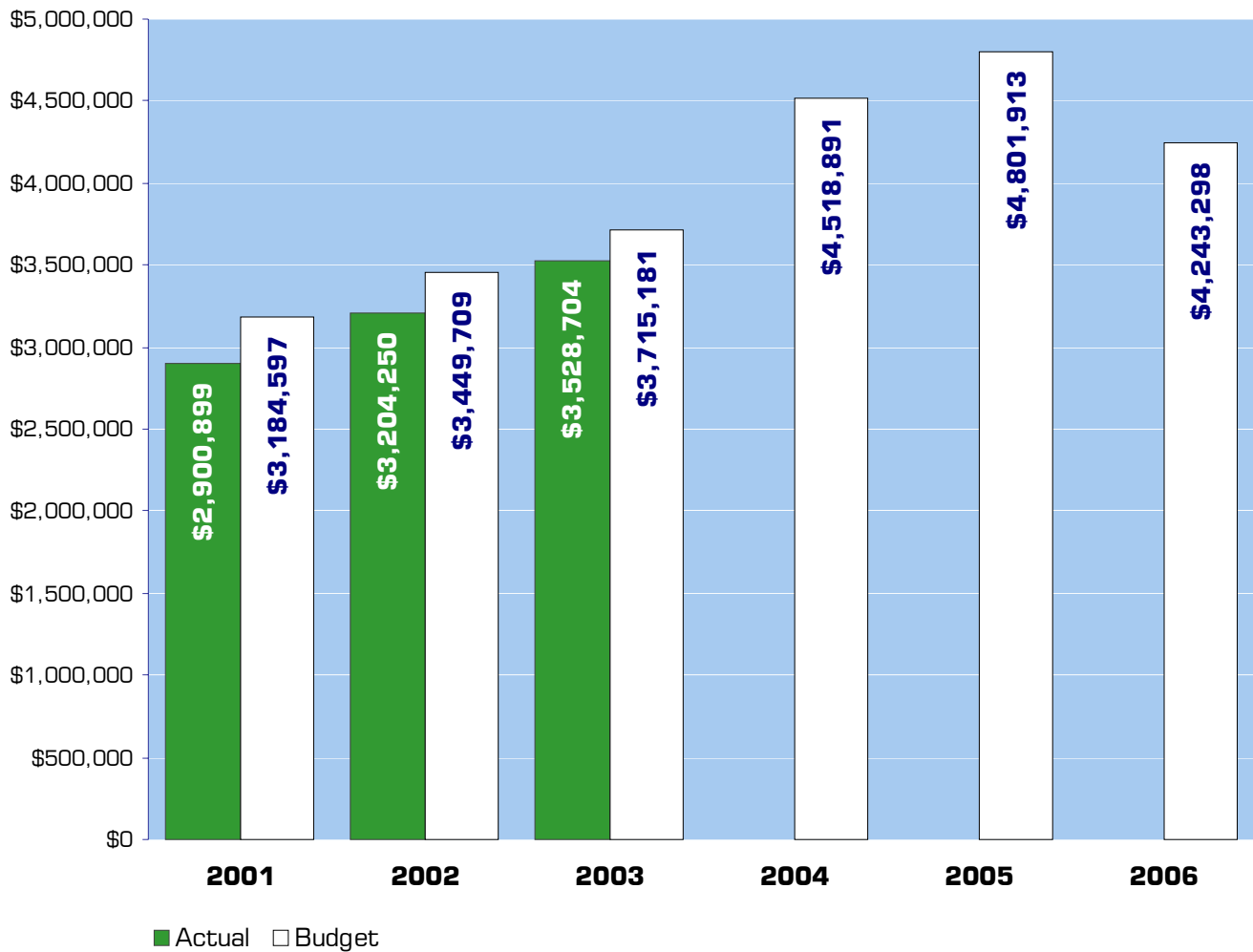

NOTE: Capital expenditures and residual equity transfers are not shown to more accurately reflect ongoing operational costs.

2005-2006 Budget by Program

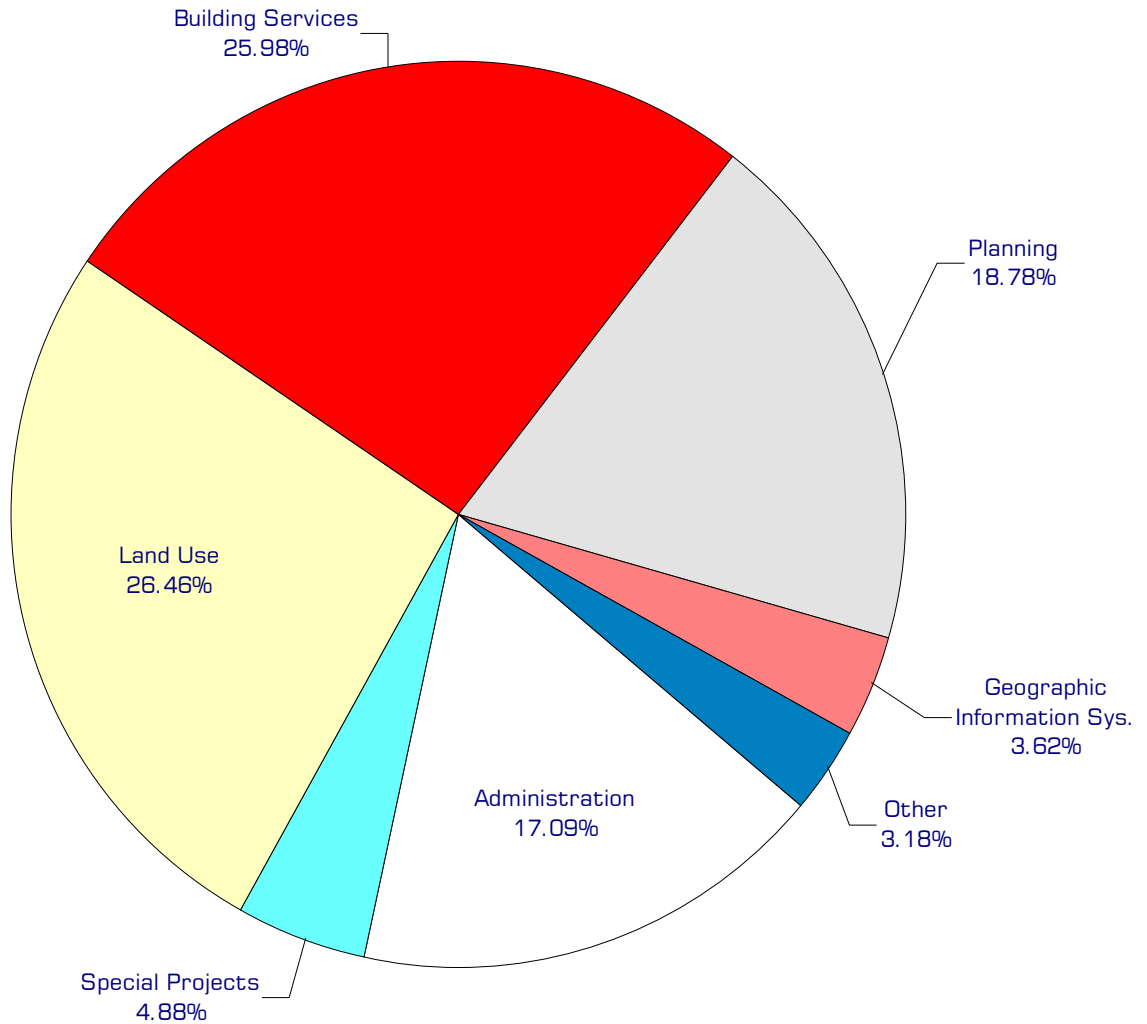

NOTE: Capital expenditures and residual equity transfers are not shown to more accurately reflect ongoing operational costs.

Program Summary

	Actual 2001	Actual 2002	Actual 2003	Budget 2004	Budget 2005	Budget 2006
OPERATIONS						
General Fund						
800 Planning & Develop. Admin	256,067	273,858	297,432	663,079	765,803	780,094
815 Special Projects	-	-	-	45,233	356,349	85,207
820 Land Use Services	967,059	1,024,836	1,150,799	1,128,525	1,195,141	1,198,607
830 Building Services	914,686	956,007	1,111,378	1,191,210	1,204,347	1,145,466
2500 Planning	559,638	536,517	689,432	777,044	837,413	861,690
2510 GIS	122,689	126,819	145,625	148,056	170,391	157,234
2561 GMA Update Grant	-	28,941	45,059	90,275	-	-
2563 WCOG Interlocal	10,000	-	-	-	-	-
2565 CZM Grant	13,500	-	19,688	1,950	-	-
2567 Birch Bay Community	57,260	38,960	-	-	-	-
2569 EDA Grant - Economic Develop	-	164,989	-	-	-	-
2570 Purchase Develop Rights	-	19,453	10,735	25,765	15,000	15,000
2571 Whatcom Conservation Distric	-	15,000	-	-	-	-
2572 GeoEngineers Contract	-	8,455	31,545	-	-	-
2573 Lummi Island Contract	-	7,885	27,011	104	-	-
2574 Paul Schissler Contract	-	2,530	-	-	-	-
2575 CDBG Grants	-	-	-	24,000	-	-
2576 DOE Shoreline Permit Grant	-	-	-	423,650	257,469	-
Total Planning & Develop Operations	2,900,899	3,204,250	3,528,704	4,518,891	4,801,913	4,243,298
CAPITAL						
General Fund						
800 Planning & Develop. Admin	14,104	13,779	38,086	34,000	-	-
820 Land Use Services	-	-	-	100	-	-
830 Building Services	-	-	4,756	4,910	-	-
2500 Planning	-	-	5,898	4,007	2,752	-
2510 GIS	6,196	-	-	-	19,750	-
2561 GMA Update Grant	-	2,607	11,651	-	-	-
2565 CZM Grant	3,000	-	-	-	-	-
2569 EDA Grant - Economic Develop	-	2,592	-	-	-	-
Total Planning & Develop. Capital	23,300	18,978	60,391	43,017	22,502	-
TRANSFERS						
General Fund						
800 Planning & Develop. Admin	1,605	-	-	30,000	52,917	39,483
815 Special Projects	-	-	-	-	7,200	7,347
820 Land Use Services	8,992	-	-	6,064	4,000	-
830 Building Services	8,452	-	-	20,000	-	-
2500 Planning	4,291	-	2,500	-	3,000	-
2510 GIS	1,158	-	-	-	-	-
Total Planning & Develop. Transfers	24,498	-	2,500	56,064	67,117	46,830
TOTAL PLAN & DEVELOPMENT	2,948,697	3,223,228	3,591,595	4,617,972	4,891,532	4,290,128
Percent Change from Previous Year	11.9%	9.3%	11.4%	28.6%	5.9%	-12.3%

2005-2006 Funding Sources

	2005	2006
Land Use Permits	564,000	559,000
Plan Check Fees	945,000	945,000
Building Permits	1,700,000	1,700,000
Intergovernmental Revenue	215,000	19,000
Other Charges for Service	526,500	526,500
General Fund	829,863	472,748
Miscellaneous Revenue	21,550	21,050
Operating Transfer-Flood	153,000	0
Total Funding	4,801,913	4,243,298

Land Use Permits

Fees collected for long and short plats and for the various land-use permits: conditional use, variance; major development, rezone, SEPA fees and exemptions from subdivision rules and lot line adjustments.

Plan Check Fees

Fees collected for the review of construction plans.

Building Permits

The department receives revenue from a variety of building related permits. The authority for the collection of these fees is based upon the Uniform Building Code and related codes and county ordinance.

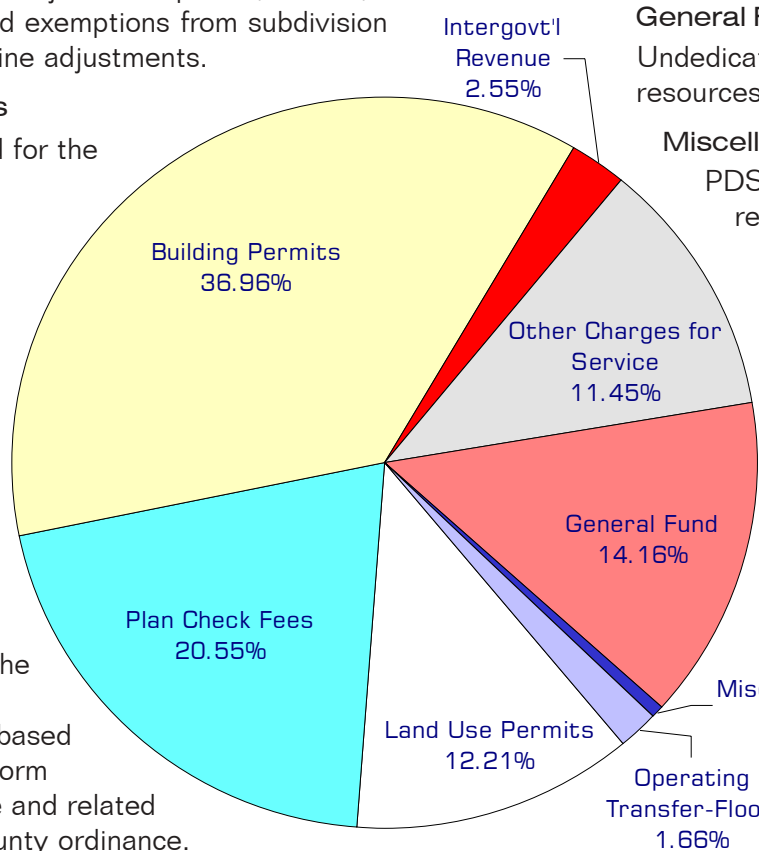

Intergovernmental Revenue

PDS received a Washington State Department of Ecology grant to update the Whatcom County Shoreline Management Program to meet new state regulations. PDS also receives \$19,000 per year from the Northwest Air Pollution Authority in support of the county's burn program.

Other Charges for Service

Planning and Development Services collects fees for annexation reviews, reviews for compliance with the Critical Area Ordinance, land clearing permits and surface mining fees.

General Fund

Undedicated General Fund resources.

Miscellaneous Revenue

PDS receives small amounts of revenue from various sources, such as the sale of publications, printing & duplicating charges, and civil fines.

Operating Transfer - Flood

The Flood Control Zone District will transfer \$153,000 to PDS to fund a storm water study in Birch Bay.

Performance / Activity Measures

	Actual 2001	Actual 2002	Actual 2003	Projected 2004	Projected 2005	Projected 2006
Permit Application - Commercial	174	165	154	158	158	158
Permit Application - Detached Building	392	455	561	506	506	506
Permit Application - Mobile Homes	226	238	216	164	164	164
Permit Application - New Single Family Residence	531	656	949	1,194	1,194	1,194
Permit Application - Single Family Addition/Remodel	280	316	310	330	330	330
Permit Application - Mechanical/Plumbing	869	778	844	800	800	800
Permit Application - Fire Alarm/Sprinkler System	31	37	30	26	26	26
Permit Application - Fire Commercial Ground Tanks	19	21	18	12	12	12
Permit Application - Burn Permits	283	377	316	380	380	380
Master Plan Review	2	19	24	22	22	22
Revised Building Plan Review	66	72	96	288	288	288
Fire Plan Review	200	646	400	864	864	864
Final Review	1,439	1,673	1,993	1,790	1,790	1,790
Fire Plan Inspections	44	54	61	68	68	68
Burn Inspections	241	375	584	800	800	800
Fire Safety Inspections	200	544	446	540	540	540
Building Permit Inspections	11,955	14,243	15,416	15,706	15,706	15,706
Commercial Pre-Application Meeting	52	64	70	88	88	88
Building Services Special Meetings	167	138	138	130	130	130
Zoning Application - Administrative	56	51	48	48	48	48
Zoning Application - Conditional Use	32	19	28	23	23	23
Zoning Application - Non Conforming Use	24	14	7	12	12	12
Zoning Application - Zoning Variance	9	5	6	6	6	6
Land Disturbance Review	1,886	2,220	2,428	2,600	2,600	2,600
Fill & Grade/Clearing Review	135	129	291	282	282	282
Shoreline Conditional Use Permit	18	17	12	12	12	12
Shoreline Substantial Development Permit	26	36	13	24	25	24
Shoreline Variance Permit	22	14	7	7	7	7
Shoreline Exemption Permit	150	225	331	200	227	215
Subdivision Long Plat	7	5	5	6	6	6
Subdivision Binding Site Plan	6	-	1	2	2	2
Subdivision Major Development	-	1	2	1	1	1

Performance / Activity Measures continued

	Actual 2001	Actual 2002	Actual 2003	Projected 2004	Projected 2005	Projected 2006
Subdivision Planned Unit Development	-	4	2	2	2	2
Subdivision Exemption	450	426	632	768	768	768
Subdivision Short Plat	45	39	44	62	62	62
Enforcement Land Use/Building	416	372	534	1,164	1,164	1,164
Enforcement Land Use Appeal	17	17	16	40	40	40
Zoning Review	4,946	5,893	7,602	7,916	7,916	7,916
Critical Area Map Check	1,886	2,220	2,428	2,600	2,600	2,600
Clearing/Grading Inspections	10	39	95	556	556	556
Natural Resources (NR) Wetland Site Review			1,067	1,144	1,144	1,144
NR Geological Hazard Review	284	357	528	500	500	500
NR Endangered Species Review			59	50	50	50
NR Watershed Review			470	480	618	641
NR SEPA Review	310	405	524	446	446	446
NR Repeat Permit Review	7	14	73	70	70	70
NR Wetlands Site Inspection	633	523	535	550	550	550
NR Geological Hazard Inspection	34	32	49	40	40	40
NR Special District - Watershed Inspection		105	387	400	400	400
NR Shoreline Inspection		43	15	24	24	24
NR Enforcement Inspection	295	241	651	1,000	1,000	1,000
Subdivision Exemption Research	399	410	462	500	500	500
Surface Mining	86	88	100	100	100	100
Critical Area Mitigation Plan	79	93	100	100	100	100
Commercial Landscaping	35	36	29	30	30	30
Conversion Option Harvest Reviews	16	9	4	4	18	17
Land Use Pre-application Meeting			35	44	44	44
Technical Review Committee Meetings	22	36	26	22	44	44
Land Use Special Meetings	239	265	439	400	400	400
Land Use Hearings			40	104	104	104
Forest Practice Applications	135	135	210	228	168	168
Open Space Applications	40	20	21	20	25	24
Subarea Plan Updates	2	1	-	2	1	1
GIS/Maps/DATA	1,500	875	1,500	1,800	1,800	1,800
Zoning/Comp Plan Interpretations	300	150	300	380	380	380
Zoning Text Amendments	20	11	21	20	20	20

Note: This represents the best available data to date. We anticipate increase in data information as data entry capabilities improve.

Expenditures Summary

	Actual 2001	Actual 2002	Actual 2003	Budget 2004	Budget 2005	Budget 2006
GENERAL FUND						
800 Administration						
Salaries & Wages	113,108	118,894	129,735	210,999	227,004	233,666
Benefits	26,704	25,719	27,875	55,363	63,357	69,939
Supplies	1,033	1,572	1,151	1,750	14,034	5,223
Other Services & Charges	115,222	127,673	138,671	394,967	461,408	471,266
Capital Outlay	14,104	13,779	38,086	34,000	-	-
Operating Transfer	1,605	-	-	30,000	52,917	39,483
<i>Total Administration</i>	<i>271,776</i>	<i>287,637</i>	<i>335,518</i>	<i>727,079</i>	<i>818,720</i>	<i>819,577</i>
<i>Percent Change from Previous Year</i>	<i>8.8%</i>	<i>5.8%</i>	<i>16.6%</i>	<i>116.7%</i>	<i>12.6%</i>	<i>0.1%</i>
815 Special Projects						
Salaries & Wages	-	-	-	36,722	62,592	62,952
Benefits	-	-	-	8,511	16,382	18,317
Supplies	-	-	-	-	1,250	805
Other Services & Charges	-	-	-	-	276,125	3,133
Operating Transfer	-	-	-	-	7,200	7,347
<i>Total Special Projects</i>	<i>-</i>	<i>-</i>	<i>-</i>	<i>45,233</i>	<i>363,549</i>	<i>92,554</i>
<i>Percent Change from Previous Year</i>	<i>0.0%</i>	<i>0.0%</i>	<i>0.0%</i>	<i>0.0%</i>	<i>703.7%</i>	<i>-74.5%</i>
820 Land Use						
Salaries & Wages	640,662	687,904	778,334	802,573	868,786	860,040
Benefits	174,407	184,399	209,056	226,062	268,365	288,143
Supplies	14,085	9,071	12,333	14,093	18,200	11,030
Other Services & Charges	137,905	143,462	151,076	85,797	39,790	39,394
Capital Outlay	-	-	-	100	-	-
Operating Transfer	8,992	-	-	6,064	-	-
Residual Equity Transfer	-	-	-	-	4,000	-
<i>Total Land Use</i>	<i>976,051</i>	<i>1,024,836</i>	<i>1,150,799</i>	<i>1,134,689</i>	<i>1,199,141</i>	<i>1,198,607</i>
<i>Percent Change from Previous Year</i>	<i>2.3%</i>	<i>5.0%</i>	<i>12.3%</i>	<i>-1.4%</i>	<i>5.7%</i>	<i>0.0%</i>
830 Building Services						
Salaries & Wages	627,972	657,827	781,843	841,666	883,195	818,696
Benefits	171,328	173,830	207,890	239,128	275,952	281,669
Supplies	13,936	14,134	18,598	29,968	17,950	17,476
Other Services & Charges	101,450	110,216	103,047	80,348	27,250	27,625
Intergov Services & Charge	-	-	-	100	-	-
Capital Outlay	-	-	4,756	4,910	-	-
Operating Transfer	8,452	-	-	-	-	-
Residual Equity Transfer	-	-	-	20,000	-	-
<i>Total Building Services</i>	<i>923,138</i>	<i>956,007</i>	<i>1,116,134</i>	<i>1,216,120</i>	<i>1,204,347</i>	<i>1,145,466</i>
<i>Percent Change from Previous Year</i>	<i>13.9%</i>	<i>3.6%</i>	<i>16.7%</i>	<i>9.0%</i>	<i>-1.0%</i>	<i>-4.9%</i>

continued on next page

Expenditures Summary continued

	Actual 2001	Actual 2002	Actual 2003	Budget 2004	Budget 2005	Budget 2006
2500 Planning						
Salaries & Wages	341,601	350,325	464,758	525,172	578,587	580,941
Benefits	89,115	86,916	117,941	137,051	161,753	183,137
Supplies	19,953	21,135	26,410	24,693	25,700	22,400
Other Services & Charges	108,969	78,141	80,323	90,128	71,373	75,212
Capital Outlay	-	-	5,898	4,007	2,752	-
Operating Transfer	4,291	-	-	-	-	-
Residual Equity Transfer	-	-	2,500	-	3,000	-
<i>Total Planning</i>	<i>563,929</i>	<i>536,517</i>	<i>697,830</i>	<i>781,051</i>	<i>843,165</i>	<i>861,690</i>
<i>Percent Change from Previous Year</i>	<i>13.2%</i>	<i>-4.9%</i>	<i>30.1%</i>	<i>11.9%</i>	<i>8.0%</i>	<i>2.2%</i>
2510 GIS						
Salaries & Wages	85,380	91,212	102,943	104,563	106,696	106,816
Benefits	22,393	22,301	26,349	26,653	30,095	33,518
Supplies	4,819	4,041	4,845	3,350	6,700	4,100
Other Services & Charges	10,097	9,265	11,488	13,490	26,900	12,800
Capital Outlay	6,196	-	-	-	19,750	-
Operating Transfer	1,158	-	-	-	-	-
<i>Total GIS</i>	<i>130,043</i>	<i>126,819</i>	<i>145,625</i>	<i>148,056</i>	<i>190,141</i>	<i>157,234</i>
<i>Percent Change from Previous Year</i>	<i>5.4%</i>	<i>-2.5%</i>	<i>14.8%</i>	<i>1.7%</i>	<i>28.4%</i>	<i>-17.3%</i>
2561 GMA Update Grant						
Salaries & Wages	-	167	-	-	-	-
Supplies	-	3,210	-	-	-	-
Other Services & Charges	-	25,564	45,059	90,275	-	-
Capital Outlay	-	2,607	11,651	-	-	-
<i>Total GMA Update Grant</i>	<i>-</i>	<i>31,548</i>	<i>56,710</i>	<i>90,275</i>	<i>-</i>	<i>-</i>
<i>Percent Change from Previous Year</i>	<i>0.0%</i>	<i>0.0%</i>	<i>79.8%</i>	<i>59.2%</i>	<i>-100.0%</i>	<i>0.0%</i>
2563 WCOG Interlocal						
Salaries & Wages	9,000	-	-	-	-	-
Supplies	1,000	-	-	-	-	-
<i>Total WCOG Interlocal</i>	<i>10,000</i>	<i>-</i>	<i>-</i>	<i>-</i>	<i>-</i>	<i>-</i>
<i>Percent Change from Previous Year</i>	<i>0.0%</i>	<i>-100.0%</i>	<i>0.0%</i>	<i>0.0%</i>	<i>0.0%</i>	<i>0.0%</i>
2565 CZM Grant						
Salaries & Wages	11,500	-	14,967	-	-	-
Benefits	-	-	-	-	-	-
Supplies	2,000	-	4,721	1,950	-	-
Other Services & Charges	-	-	-	-	-	-
Capital Outlay	3,000	-	-	-	-	-
<i>Total CZM Grant</i>	<i>16,500</i>	<i>-</i>	<i>19,688</i>	<i>1,950</i>	<i>-</i>	<i>-</i>
<i>Percent Change from Previous Year</i>	<i>0.0%</i>	<i>-100.0%</i>	<i>0.0%</i>	<i>-90.1%</i>	<i>-100.0%</i>	<i>0.0%</i>
2567 Birch Bay Community						
Supplies	1,500	-	-	-	-	-
Other Services & Charges	55,760	38,960	-	-	-	-
<i>Total Birch Bay Community</i>	<i>57,260</i>	<i>38,960</i>	<i>-</i>	<i>-</i>	<i>-</i>	<i>-</i>
<i>Percent Change from Previous Year</i>	<i>0.0%</i>	<i>-32.0%</i>	<i>-100.0%</i>	<i>0.0%</i>	<i>0.0%</i>	<i>0.0%</i>

continued on next page

Expenditures Summary continued

	Actual 2001	Actual 2002	Actual 2003	Budget 2004	Budget 2005	Budget 2006
2569 EDA Grant - Economic Development						
Salaries & Wages	-	5,495	-	-	-	-
Benefits	-	494	-	-	-	-
Other Services & Charges	-	159,000	-	-	-	-
Capital Outlay	-	2,592	-	-	-	-
<i>Total EDA Grant-Economic Devel</i>	-	167,581	-	-	-	-
<i>Percent Change from Previous Year</i>	0.0%	0.0%	-100.0%	0.0%	0.0%	0.0%
2570 Purchase Develop Rights						
Other Services & Charges	-	19,453	10,735	25,765	15,000	15,000
<i>Total Purchase Develop Rights</i>	-	19,453	10,735	25,765	15,000	15,000
<i>Percent Change from Previous Year</i>	0.0%	0.0%	-44.8%	140.0%	-41.8%	0.0%
2571 Whatcom Conservation District						
Other Services & Charges	-	15,000	-	-	-	-
<i>Total Whatcom Conservation Distric</i>	-	15,000	-	-	-	-
<i>Percent Change from Previous Year</i>	0.0%	0.0%	-100.0%	0.0%	0.0%	0.0%
2572 GeoEngineers Contract						
Other Services & Charges	-	8,455	31,545	-	-	-
<i>Total GeoEngineers Contract</i>	-	8,455	31,545	-	-	-
<i>Percent Change from Previous Year</i>	0.0%	0.0%	273.1%	-100.0%	0.0%	0.0%
2573 Lummi Island Contract						
Other Services & Charges	-	7,885	27,011	104	-	-
<i>Total Lummi Island Contract</i>	-	7,885	27,011	104	-	-
<i>Percent Change from Previous Year</i>	0.0%	0.0%	242.6%	-99.6%	-100.0%	0.0%
2574 Schissler Contract						
Other Services & Charges	-	2,530	-	-	-	-
<i>Total Schissler Contract</i>	-	2,530	-	-	-	-
<i>Percent Change from Previous Year</i>	0.0%	0.0%	-100.0%	0.0%	0.0%	0.0%
2575 CDBG Grants						
Other Services & Charges	-	-	-	24,000	-	-
<i>Total CDBG Grants</i>	-	-	-	24,000	-	-
<i>Percent Change from Previous Year</i>	0.0%	0.0%	0.0%	0.0%	-100.0%	0.0%
2576 DOE Shoreline Permit						
Salaries & Wages	-	-	-	73,714	74,500	-
Benefits	-	-	-	21,536	23,969	-
Other Services & Charges	-	-	-	328,400	159,000	-
<i>Total DOE Shoreline Permit</i>	-	-	-	423,650	257,469	-
<i>Percent Change from Previous Year</i>	0.0%	0.0%	0.0%	0.0%	-39.2%	-100.0%
TOTAL PLAN & DEVELOP SVCS	2,948,697	3,223,228	3,591,595	4,617,972	4,891,532	4,290,128
<i>Percent Change from Previous Year</i>	11.9%	9.3%	11.4%	28.6%	5.9%	-12.3%

Services

Archeological Reviews

Review of archaeological site inquiries for Point Roberts property owners, realtors and contractors. Provide archaeological site review using confidential GIS information.

Building Reviews

Review and enforcement of mandated zoning and life safety codes.

Code Compliance

Education and enforcement of land use, development, natural resource development, natural resources and building regulations.

Land Disturbance

Reviews for approval of land clearing, fill, grading, erosion control and forest practices.

Natural Resources Program

Review and approval of development activity within or near regulated water resource protection areas and critical areas. Review and approval of regulated surface mines. Protection of agricultural land and forests, and update of regulations to comply with state and federal requirements.

Open Space

Develop and administer programs relating to conservation of open space, including open space tax programs, purchase or transfer of development rights, and acquisition of land or easements.

Permit Coordination

Permit services include development permit intake, permit routing and tracking, permit issuance and research at the request of the public or staff, including cashiering.

Plan Review

Provide non-structural and structural review of residential and commercial plans, including manufactured structures.

SEPA Reviews

Review of threshold determination on all projects, public and private subject to Whatcom County jurisdiction and which do not qualify for a SEPA exemption. Provides supervision of writing of Environmental Impact Statements.

Shoreline Program

Review and permitting for all development proposals within 200 feet of the Ordinary High Water Mark of regulated shorelines, including periodic update of regulations and data. Complete mandated update of Shoreline Management Program.

Subdivision Review

Review and approval/ recommendation of short plat/long plat applications and other permits and approvals authorized by Title 21.

Services continued

Zoning Administration

Respond to citizen inquiries; review and make recommendations regarding approval of permits authorized under the zoning code. Process citizen applications, Council and Planning Commission request for changes to zoning maps and text.

Data/Records

Specialized database development, software support and maintenance of system for permit tracking, recording inspection results, land use and environmental data, filing and records retention.

Fire

Review of permits, plat applications and provides on-site site inspections including new construction, fire alarm and sprinkler system installations, fire extinguisher placement, emergency exiting, storage and handling of hazardous materials. Oversee outdoor burn program. Arson investigation.

Inspections/Life Safety

Field inspection and enforcement of mandated zoning and life safety codes.

Comprehensive Plan Revisions

Processes applications, Council and Planning Commission requests for changes to the Comprehensive Plan, map and text, Sub-area Plans, Economic Development and Capital Facilities Plan.

Prosecuting Attorney

An elected official, the Prosecuting Attorney prosecutes criminal acts within the county, provides legal advice and legal services to county officials and staff, and represents and defends the county. The Prosecuting Attorney's Office also provides assistance to victims of crime, sexual abuse and domestic violence.

FTE's for this department

Year	2001	2002	2003	*2004	*2005	*2006	*budget
FTE	48.50	47.50	48.60	48.60	50.60	50.60	

The chart below shows the organizational structure for 2005 only.

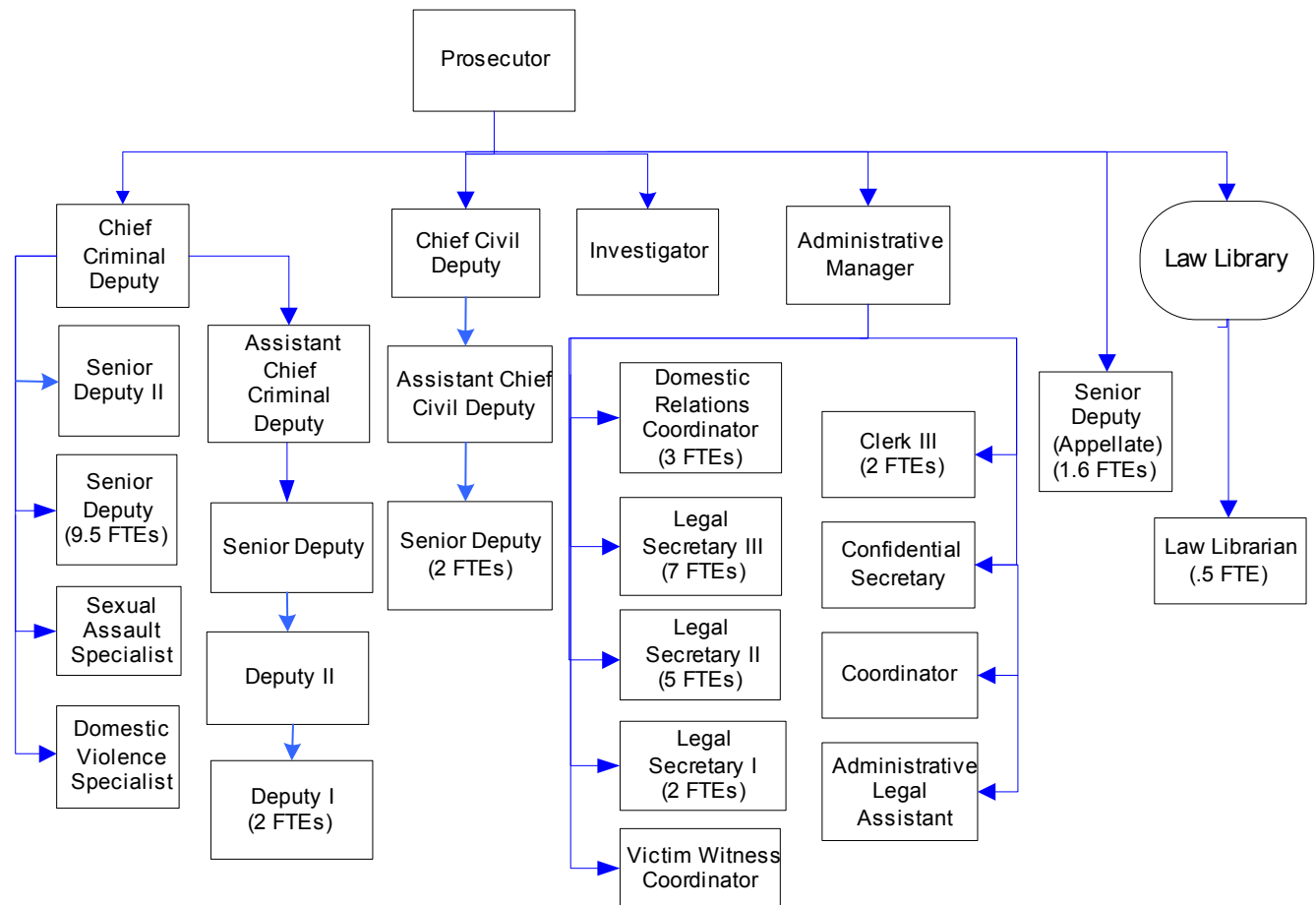

Mission & Objectives

Mission

Prosecuting Attorney

Provide just, equitable and high quality legal representation, effectively and efficiently, when prosecuting criminal actions, when advising or defending county officials or employees on civil matters that pertain to or affect the interests of the county and when carrying out statutorily mandated duties on behalf of the State of Washington.

Seek to ensure that justice is accomplished within the framework of the United States constitution, the state constitution and the laws of this state. Provide services to victims and witnesses to ensure their fair treatment within the criminal justice system. Identify, locate and compel the absent parents of children receiving state assistance to pay for the support of their children instead of the public.

Assist in developing goals and objectives for the criminal justice system that ensure delivery of services to the community that enhance public safety.

Law Library

Provide a fundamental level of current legal materials unavailable elsewhere in the county. Meet the legal research needs of the courts, the bar association, county employees and the citizens of Whatcom County. To implement this mission, the library provides access to legal information sources in the most cost-effective manner through print or electronic means and through interlibrary loan.

Objectives

- Identify and implement procedures that use technology to maximize efficiency and ensure production of consistent, high quality work product. To achieve this, staff resources have been committed to research, design and implement innovative technological solutions that improve efficiency in case processing. In 2005-2006, this means complete the implementation of the Laserfiche RMS, including the workflow component.
- Maintain use of the following performance measures as a means to define sufficient staffing and funding levels:
 - Felony cases** - 10 working days from receipt of incident report to charging decision. The 2004 level currently stands at 22 days. In 2005 the goal is 17 days.
 - Juvenile Division** - 7 working days from receipt of incident report to charging decision. The 2004 level currently stands at 35. In 2005 the goal is 29 days.
 - District Court Division** - 150 days from filing date to final disposition which was established commencing January 1, 2000. The 2004 level currently stands at 191. In 2005 this measure is expected to come in at 192 days.
- Create and deploy a digital brief bank utilizing software, with natural language selection search capabilities, that facilitates retrieval by appeal topic or legal issue.

Objectives continued

- Develop and implement performance measures for all divisions in the office. Specific focus in 2005, will continue to be on defining measures for the Victim/Witness Unit and the Civil Division.
- Allocate sufficient departmental staff resources, as necessary, to assure the success of the MIS data integration project.

Drug Fund

- Ensure continuation and possible expansion of cooperative agreements with DEA and Customs for equitable sharing of forfeited assets.
- Utilize fund resources to continue the aggressive prosecution of individuals who violate Title 69, Violations of Uniform Controlled Substances Act.

Victim / Witness

- Review workloads and paperflows with a view toward restructuring, reorganization and/or expansion of the unit.

Law Library

- Provide a fundamental level of current legal materials unavailable elsewhere in the county, to meet the legal research needs of the courts, the bar, county employees and citizens of Whatcom County.
- Provide access to legal information sources in the most cost-effective manner through print or electronic formats maintained in or accessed through the library, interlibrary loan, and referral to document delivery sources.
- Participate in cooperative efforts with other public and academic libraries, community agencies, and other public institutions to improve public access to legal information.
- Evaluate and apply information technologies to maximize efficient and cost-effective access to legal research resources, and to facilitate management of the Law Library's information resources.
- Seek out additional funding sources to keep pace with rising costs of legal materials.

Expenditure Trends

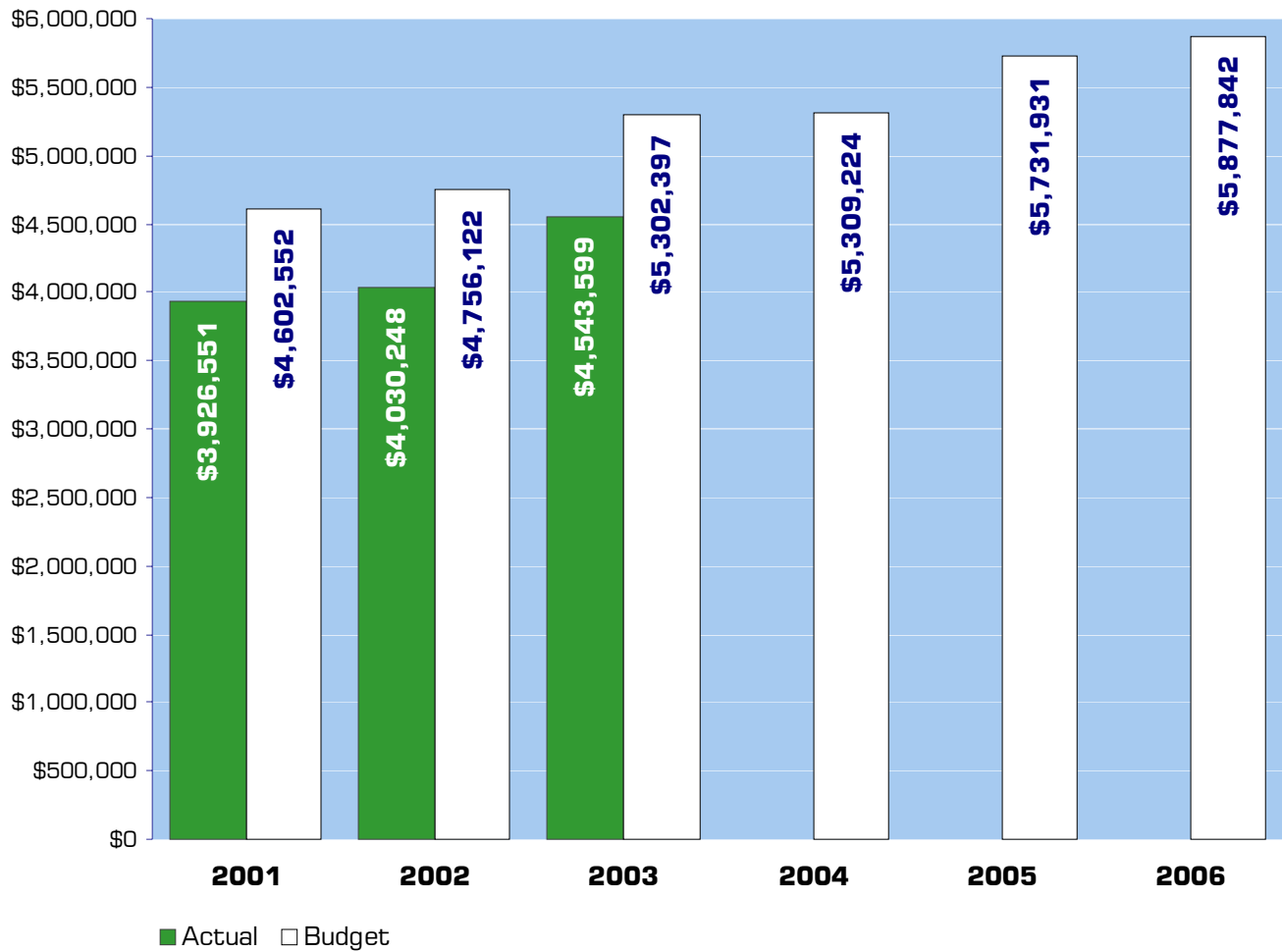

NOTE: Capital expenditures and interfund operating transfers are not shown to more accurately reflect ongoing operational costs.

2005-2006 Budget by Program

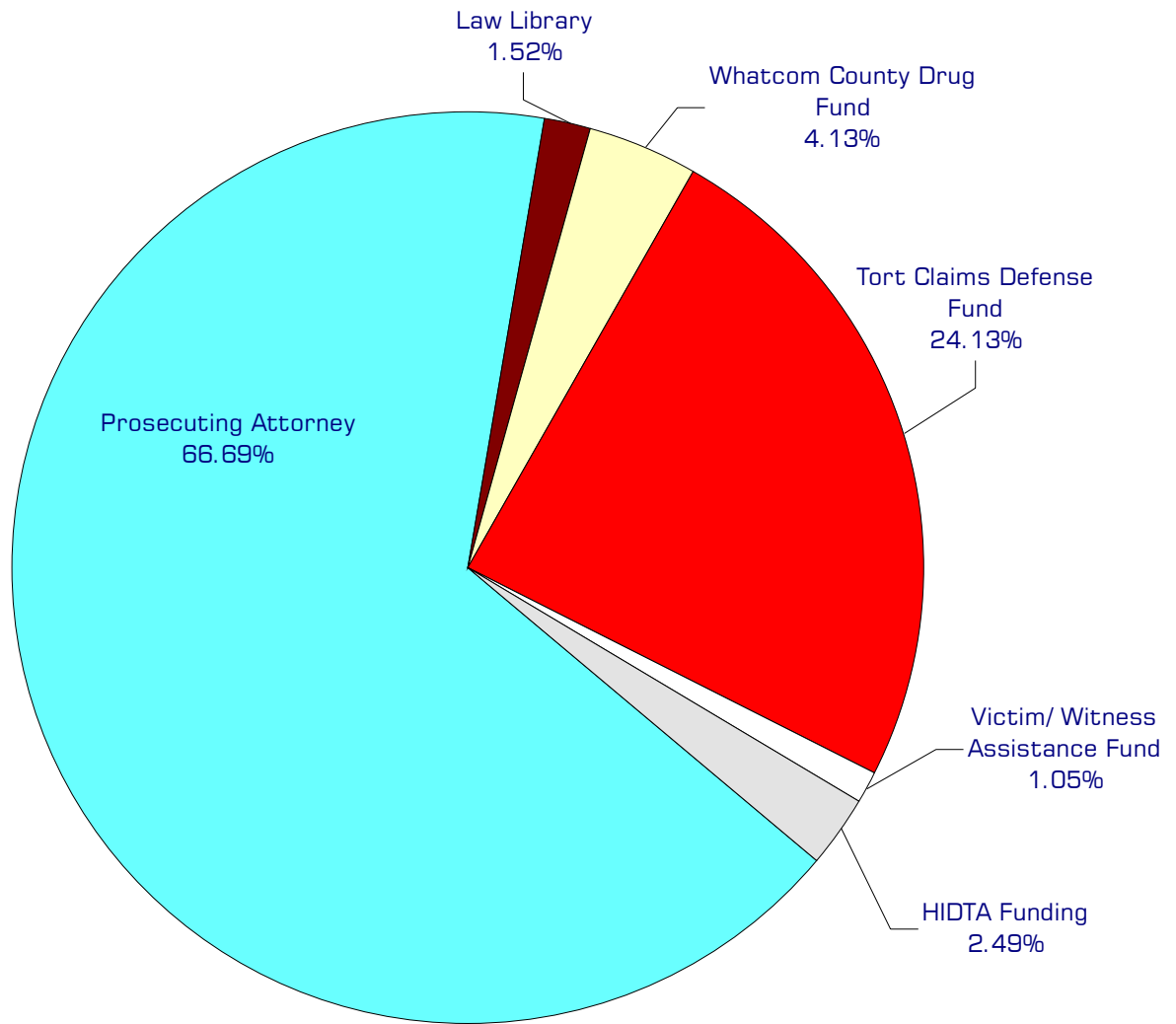

NOTE: Capital expenditures and interfund operating and residual equity transfers are not shown to more accurately reflect ongoing operational costs.

Program Summary

	Actual 2001	Actual 2002	Actual 2003	Budget 2004	Budget 2005	Budget 2006
OPERATIONS						
General Fund						
2600 Pros Atty/Support Enforcmt	3,100,258	3,191,817	3,357,218	3,578,514	3,796,101	3,946,093
2630 Law Library	83,189	90,439	89,101	80,829	86,824	89,082
2640 PA-HIDTA Funding	113,139	113,228	125,885	123,489	141,169	147,879
507 ADS - General Liability	457,255	469,323	762,126	1,285,043	1,400,727	1,400,727
142 Victim/Witness Assist Fund	49,960	54,226	51,932	56,349	60,110	62,061
165 Whatcom Co. Drug Fund	122,750	111,215	157,337	185,000	247,000	232,000
<i>Total Prosecuting Atty Operations</i>	3,926,551	4,030,248	4,543,599	5,309,224	5,731,931	5,877,842
CAPITAL						
General Fund						
2600 Pros. Atty/Support Enforcmt	10,007	-	-	14,000	-	-
165 Whatcom Co. Drug Fund	16,731	2,167	63,758	100,000	50,000	50,000
<i>Total Prosecuting Attorney Capital</i>	26,738	2,167	63,758	114,000	50,000	50,000
TRANSFERS						
General Fund						
2600 Pros. Atty/Support Enforcmt	29,294	1,500	1,500	1,500	1,500	1,500
2630 Law Library	198	-	-	-	-	-
2640 PA-HIDTA Funding	1,155	-	-	-	-	-
507 ADS - General Liability	118,840	118,840	119,372	122,788	125,532	125,532
142 Victim/Witness Assist Fund	58,682	71,651	53,844	60,815	63,986	63,986
165 Whatcom Co. Drug Fund	348,233	377,403	414,330	424,400	440,472	426,407
<i>Total Pros Attorney Transfers</i>	556,402	569,394	589,046	609,503	631,490	617,425
TOTAL PROSECUTING ATTORNEY	4,509,691	4,601,809	5,196,403	6,032,727	6,413,421	6,545,267
<i>Percent Change from Previous Year</i>	6.7%	2.0%	12.9%	16.1%	6.3%	2.1%

2005-2006 Funding Sources

	2005	2006
Intergovernmental Revenues	828,006	840,218
General Fund	3,140,715	3,287,463
Law Library Revenues	55,373	55,373
Fines & Forfeits	247,000	232,000
General Government Fees	60,110	62,061
Interfund Transfer	1,074,157	1,074,157
*Fund Balance	326,570	326,570
Total Funding	5,731,931	5,877,842

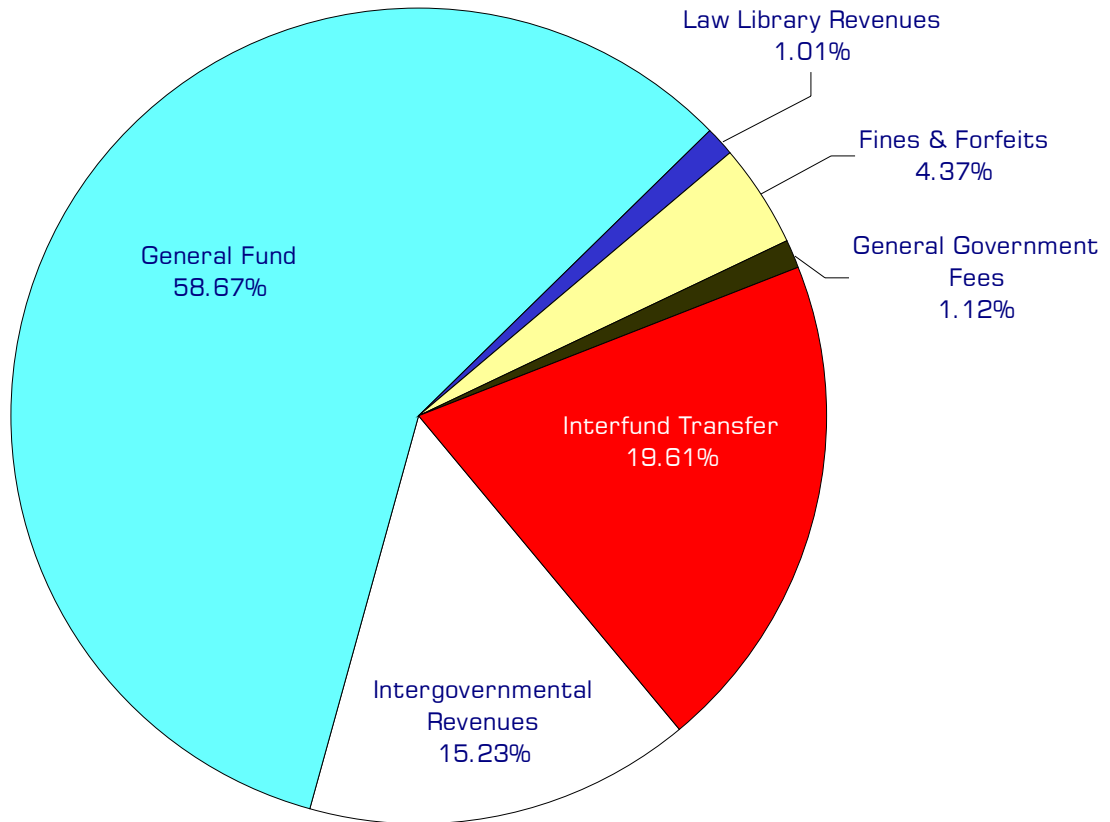

*Fund balance is not included in the above chart.

Funding Sources continued

Grants

The Prosecuting Attorney's Office receives various federal and state grants for specific operations. The federal government provides approximately \$615,000 annually for Child Support Enforcement and \$145,000 annually for drug traffic prosecution. The department receives \$12,000 per year as part of Washington State's Multi-Jurisdictional Narcotics Task Force Grant. Additionally, pursuant to RCW 36.17.020, Washington State pays for one half of the Prosecuting Attorney's salary.

General Fund

Undedicated General Fund resources.

Law Library Revenues

The Law Library receives a fee of \$6 on each District Court civil filing and \$12 for each Superior Court civil filing. The library also receives donations and facility rental revenue.

Fines & Forfeits

The Drug Fund receives revenue from fines and forfeits of drug-related seized assets.

General Government Fees

Fee revenues collected by District Court and Superior Court, which are dedicated to support the Victim/Witness Fund.

Interfund Transfer

Each county department contributes a set amount for tort claims. These contributions total \$1,074,157. Reserves for tort claims are maintained in the Administrative Services Fund.

Fund Balance

Current year operations will result in a projected decrease to the Prosecuting Attorney's dedicated fund balance in the Administrative Services - Tort Fund for liability insurance.

Performance / Activity Measures

	Actual 2001	Actual 2002	Actual 2003	Projected 2004	Projected 2005	Projected 2006
District Court Cases - days to disposition (goal is 180 or less)	164	166	186	191	192	192
Superior Court Cases- days to charging (goal is 10 or less)	25	21	23	22	17	17
Juvenile Cases- days to charging (goal is 7 or less)	53	46	29	35	29	29
<i>Law Library</i>						
Volumes	18,660	20,650	22,000	22,500	23,000	23,500
Interlibrary loan requests	60	60	60	40	40	40
Attorney visits	1,500	1,500	1,525	1,525	1,525	1,525
Non-attorney visits	1,600	1,700	1,700	1,700	1,725	1,725
Requests for assistance and information	1,600	1,600	1,625	1,625	1,650	1,650
Library hours of staff present per week	20	20	20	20	20	20
Subscriptions	41	37	35	30	30	30
Usage of CD-ROM computer - times accessed	2,750	2,750	3,000	3,000	3,000	3,000
<i>Tort Claims</i>						
General Liability - Claims against Whatcom County	44	65	70	56	59	62

Expenditures Summary

	Actual 2001	Actual 2002	Actual 2003	Budget 2004	Budget 2005	Budget 2006
GENERAL FUND						
2600 Prosecuting Attorney						
Salaries & Wages	2,092,145	2,253,866	2,365,617	2,504,128	2,617,523	2,666,551
Benefits	549,900	525,886	549,470	646,710	762,127	853,212
Supplies	58,898	60,655	54,054	70,575	64,610	60,650
Other Services & Charges	399,315	351,410	388,077	357,101	351,841	365,680
Capital Outlay	10,007	-	-	14,000	-	-
Operating Transfers	27,794	-	-	-	-	-
Residual Equity Transfers	1,500	1,500	1,500	1,500	1,500	1,500
<i>Total Prosecuting Attorney</i>	<i>3,139,559</i>	<i>3,193,317</i>	<i>3,358,718</i>	<i>3,594,014</i>	<i>3,797,601</i>	<i>3,947,593</i>
<i>Percent Change from Previous Year</i>	<i>8.1%</i>	<i>1.7%</i>	<i>5.2%</i>	<i>7.0%</i>	<i>5.7%</i>	<i>3.9%</i>
2640 PA-HIDTA Funding						
Salaries & Wages	88,626	91,155	101,286	97,893	109,169	111,909
Benefits	24,513	22,073	24,599	25,596	32,000	35,970
Operating Transfers	1,155	-	-	-	-	-
<i>Total HIDTA Funding</i>	<i>114,294</i>	<i>113,228</i>	<i>125,885</i>	<i>123,489</i>	<i>141,169</i>	<i>147,879</i>
<i>Percent Change from Previous Year</i>	<i>13.2%</i>	<i>-0.9%</i>	<i>11.2%</i>	<i>-1.9%</i>	<i>14.3%</i>	<i>4.8%</i>
LAW LIBRARY						
2630 Law Library Operations						
Salaries & Wages	15,205	17,250	19,004	19,660	20,422	21,190
Benefits	6,703	6,556	8,750	9,787	10,904	12,137
Supplies	37,831	40,289	36,370	29,498	32,505	32,510
Other Services & Charges	23,450	26,344	24,977	21,884	22,993	23,245
Operating Transfers	198	-	-	-	-	-
<i>Total Law Library</i>	<i>83,387</i>	<i>90,439</i>	<i>89,101</i>	<i>80,829</i>	<i>86,824</i>	<i>89,082</i>
<i>Percent Change from Previous Year</i>	<i>9.9%</i>	<i>8.5%</i>	<i>-1.5%</i>	<i>-9.3%</i>	<i>7.4%</i>	<i>2.6%</i>
<i>Total General Fund</i>	<i>3,337,240</i>	<i>3,396,984</i>	<i>3,573,704</i>	<i>3,798,332</i>	<i>4,025,594</i>	<i>4,184,554</i>
<i>Percent Change from Previous Year</i>	<i>8.3%</i>	<i>1.8%</i>	<i>5.2%</i>	<i>6.3%</i>	<i>6.0%</i>	<i>3.9%</i>
507 ADMIN SERVICES - GENERAL LIABILITY						
Other Services & Charges	457,255	469,323	762,126	1,285,043	1,400,727	1,400,727
Operating Transfers	118,840	118,840	119,372	122,788	125,532	125,532
<i>Total Adm Svcs - Gen'l Liability</i>	<i>576,095</i>	<i>588,163</i>	<i>881,498</i>	<i>1,407,831</i>	<i>1,526,259</i>	<i>1,526,259</i>
<i>Percent Change from Previous Year</i>	<i>-8.4%</i>	<i>2.1%</i>	<i>49.9%</i>	<i>59.7%</i>	<i>8.4%</i>	<i>0.0%</i>
142 VICTIM/ WITNESS FUND						
Salaries & Wages	34,679	38,569	35,635	37,596	39,888	39,948
Benefits	9,502	9,878	10,518	11,676	13,472	14,977
Other Services & Charges	5,779	5,779	5,779	7,077	6,750	7,136
Operating Transfers	58,682	71,651	53,844	60,815	63,986	63,986
<i>Total Victim/Witness Fund</i>	<i>108,642</i>	<i>125,877</i>	<i>105,776</i>	<i>117,164</i>	<i>124,096</i>	<i>126,047</i>
<i>Percent Change from Previous Year</i>	<i>7.0%</i>	<i>15.9%</i>	<i>-16.0%</i>	<i>10.8%</i>	<i>5.9%</i>	<i>1.6%</i>

	Actual 2001	Actual 2002	Actual 2003	Budget 2004	Budget 2005	Budget 2006
165 DRUG FUND						
Salaries & Wages	-	1,107	-	-	-	-
Supplies	18,005	2,551	2,987	20,000	65,000	50,000
Other Services & Charges	104,745	107,557	154,350	165,000	182,000	182,000
Capital Outlay	16,731	2,167	63,758	100,000	50,000	50,000
Operating Transfers	348,233	377,403	414,330	424,400	440,472	426,407
<i>Total Drug Fund</i>	487,714	490,785	635,425	709,400	737,472	708,407
<i>Percent Change from Previous Year</i>	17.0%	0.6%	29.5%	11.6%	4.0%	-3.9%
TOTAL PROSECUTING ATTY	4,509,691	4,601,809	5,196,403	6,032,727	6,413,421	6,545,267
<i>Percent Change from Previous Year</i>	6.7%	2.0%	12.9%	16.1%	6.3%	2.1%

Services

Civil Practice

Provide legal counsel and representation to all county departments, the Executive's Office and the County Council.

Criminal Prosecution/Felony

Represents the State of Washington in the prosecution of adults and remanded juveniles who commit felony offenses. Assists authorities in determining probable cause, obtaining search warrants, interpretation and application of the law, and on case investigation issues.

Criminal Prosecution/Juvenile

Represent the interests of the State of Washington in the adjudication of juvenile offenders who commit felony or misdemeanor criminal acts, excluding criminal traffic misdemeanors committed by offenders over the age of sixteen.

Criminal Prosecution/Misdemeanor & Criminal Traffic

Represent the State of Washington in the prosecution of misdemeanor and criminal traffic offenses committed by adults and in criminal traffic matters committed by juveniles who are over the age of sixteen.

Paternity/Support Enforcement Unit

Represent the interest of the child and state in legal actions brought under RCW 26, to establish paternity and/or enforce the payment of child support in an effort to reduce public assistance expenditures.

Victim/Witness Unit

Provide information, assistance and advocacy to victims or witnesses in order to facilitate prosecution efforts.

Law Library

Interlibrary Loan/Resource Sharing

Provides access to legal research resources unavailable in this library and elsewhere in Whatcom County.

Law Library

Provides effective access to legal research materials to support the legal research needs of the courts, the bar, county administration, and the public in Whatcom County.

Public Defender's Office

The Public Defender's Office provides constitutionally mandated indigent legal defense for: felony, misdemeanor and probation violation charges against adults and juveniles in Whatcom County Superior and District Courts; parents in juvenile dependency matters; involuntary mental and alcohol commitments.

FTE's for this department

Year	2001	2002	2003	*2004	*2005	*2006	*budget
FTE	28.00	28.00	28.00	28.00	31.00	32.00	

The chart below shows the organizational structure for 2005 only.

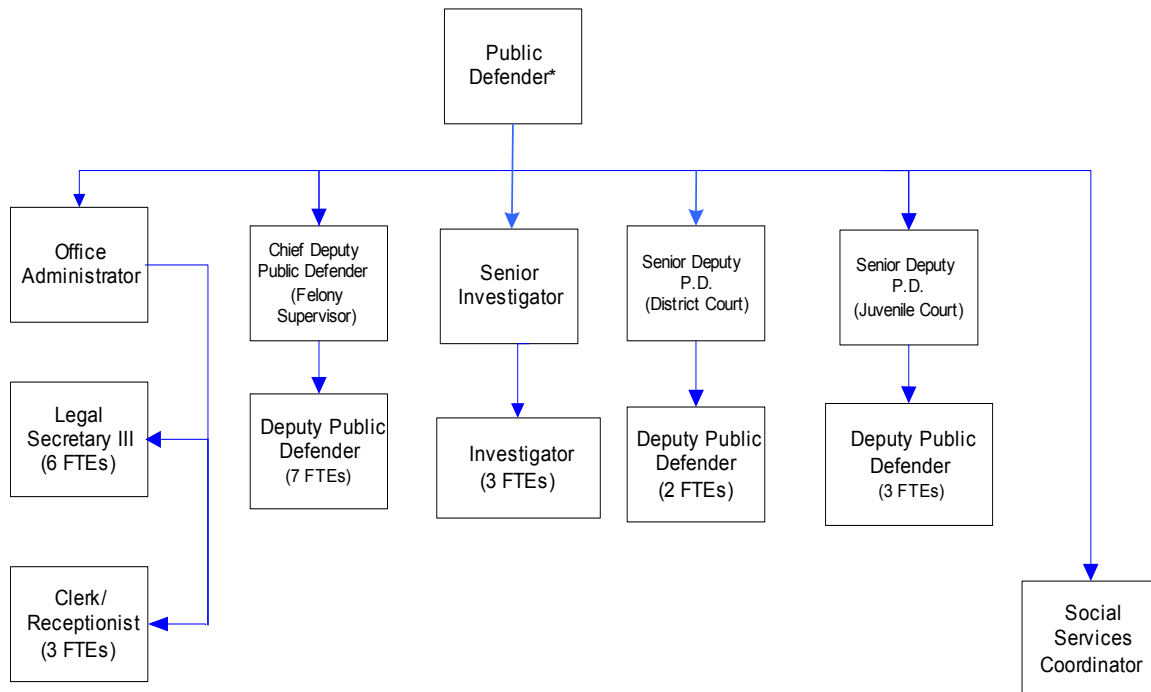

*Public Defender to carry a half-time caseload.

Mission & Objectives

Mission

The Public Defender's Office was created in 1982 by county ordinance pursuant to RCW 36.26 and mandated to provide legal representation for those who cannot afford an attorney and who are entitled to legal defense at public expense pursuant to the constitutions of the United States and the State of Washington, or pursuant to statute. The overall mission of the department is to provide high quality legal representation as efficiently and economically as possible, while maintaining the confidence of clients that they are receiving competent and skilled representation.

Objectives

- Provide competent representation to each of our clients.
- Work towards bringing our caseloads closer to national and state standards.
- Work with other branches of the criminal justice system, the Department of Social and Health Services, and the Attorney General's Office to maintain and expand drug courts and family treatment courts in Whatcom County.
- Develop a Policy and Procedures Manual for the Whatcom County Public Defender's Office.

Expenditure Trends

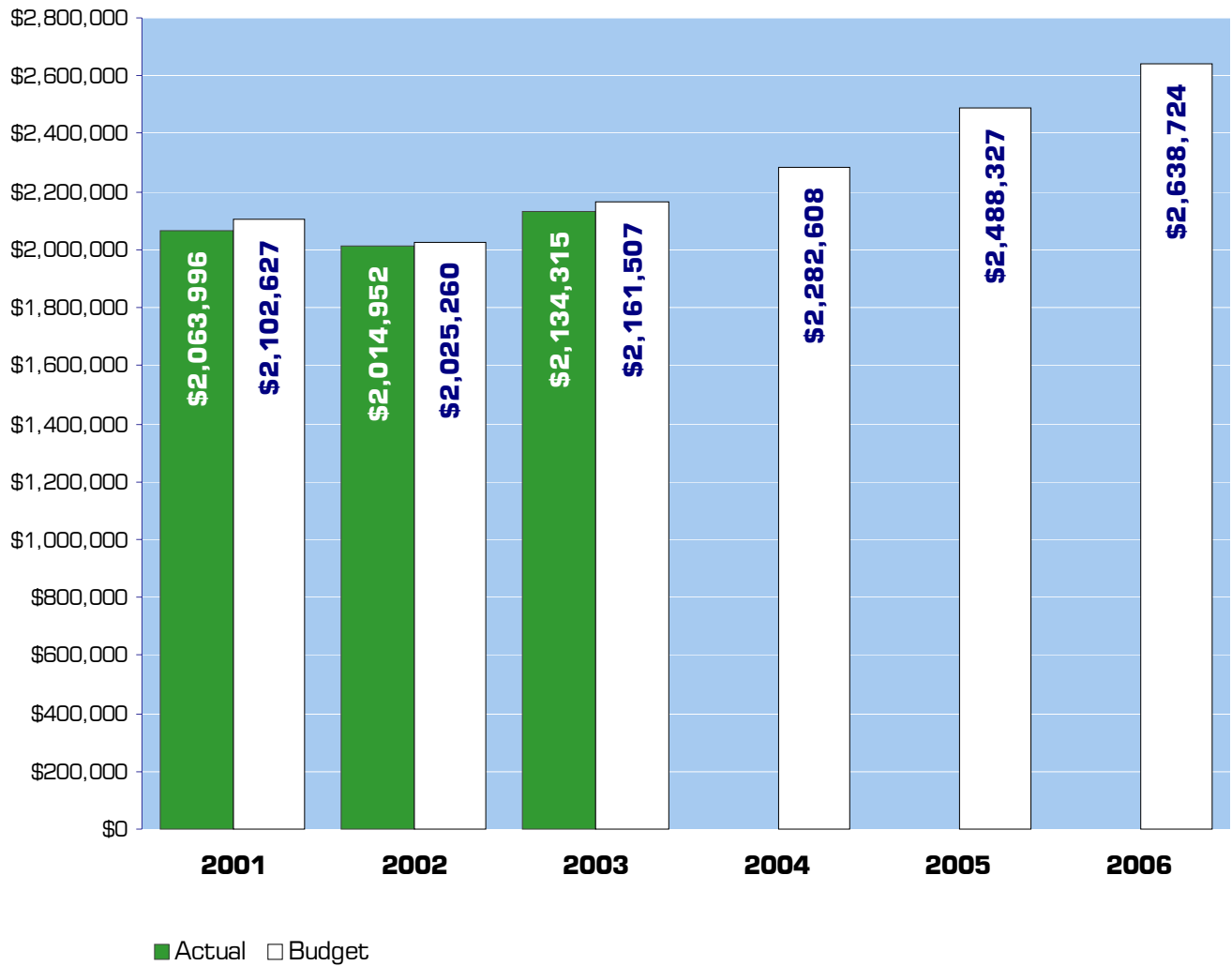

NOTE: Capital expenditures and interfund operating transfers are not shown to more accurately reflect ongoing operational costs.

2005-2006 Budget by Program

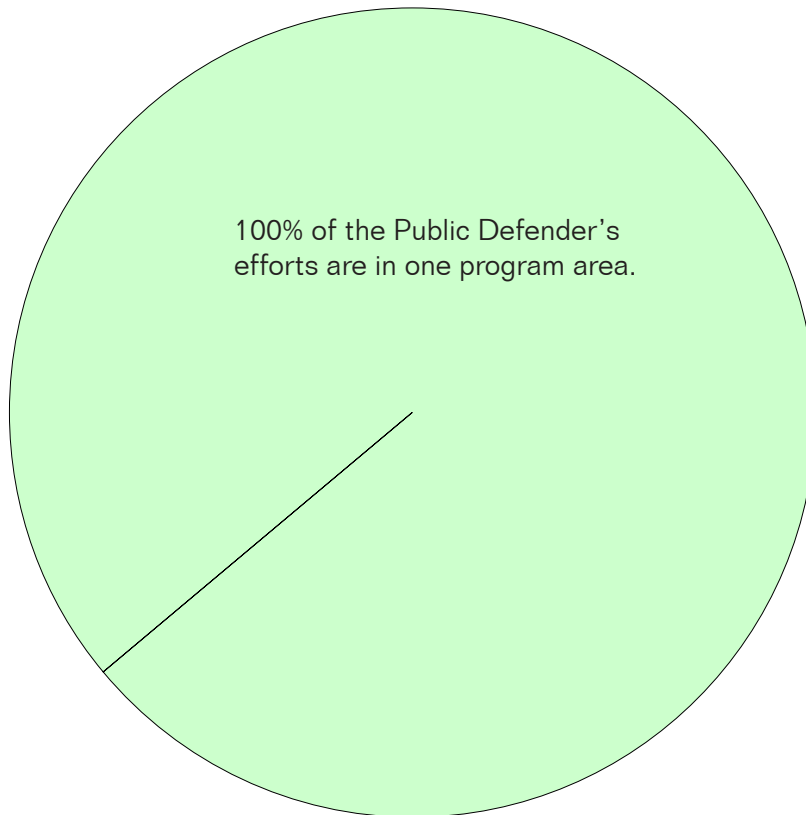

NOTE: Capital expenditures are not shown to more accurately reflect ongoing operational costs.

Program Summary

	Actual 2001	Actual 2002	Actual 2003	Budget 2004	Budget 2005	Budget 2006
OPERATIONS						
General Fund						
2650 Public Defender	1,818,220	2,008,109	2,134,315	2,282,608	2,488,327	2,638,724
2655 Public Defender-Kinney	245,776	6,843	-	-	-	-
<i>Total Public Defender Operations</i>	<i>2,063,996</i>	<i>2,014,952</i>	<i>2,134,315</i>	<i>2,282,608</i>	<i>2,488,327</i>	<i>2,638,724</i>
CAPITAL						
General Fund						
2650 Public Defender	4,836	-	-	-	-	8,937
2655 Public Defender-Kinney	10,168	-	-	-	-	-
<i>Total Public Defender Capital</i>	<i>15,004</i>	<i>-</i>	<i>-</i>	<i>-</i>	<i>-</i>	<i>8,937</i>
TRANSFERS						
General Fund						
2650 Public Defender	15,692	-	-	-	-	-
2655 Public Defender-Kinney	1,457	-	-	-	-	-
<i>Total Public Defender Transfers</i>	<i>17,149</i>	<i>-</i>	<i>-</i>	<i>-</i>	<i>-</i>	<i>-</i>
TOTAL PUBLIC DEFENDER	2,096,149	2,014,952	2,134,315	2,282,608	2,488,327	2,647,661
<i>Percent Change from Previous Year</i>	<i>19.5%</i>	<i>-3.9%</i>	<i>5.9%</i>	<i>6.9%</i>	<i>9.0%</i>	<i>6.4%</i>

2005-2006 Funding Sources

	2005	2006
Grants	19,000	19,000
General Fund	2,469,327	2,619,724
Total Funding	2,488,327	2,638,724

Grants

Revenue received from the State of Washington, based on the funding model for the Becca Bill.

General Fund

Undedicated General Fund resources.

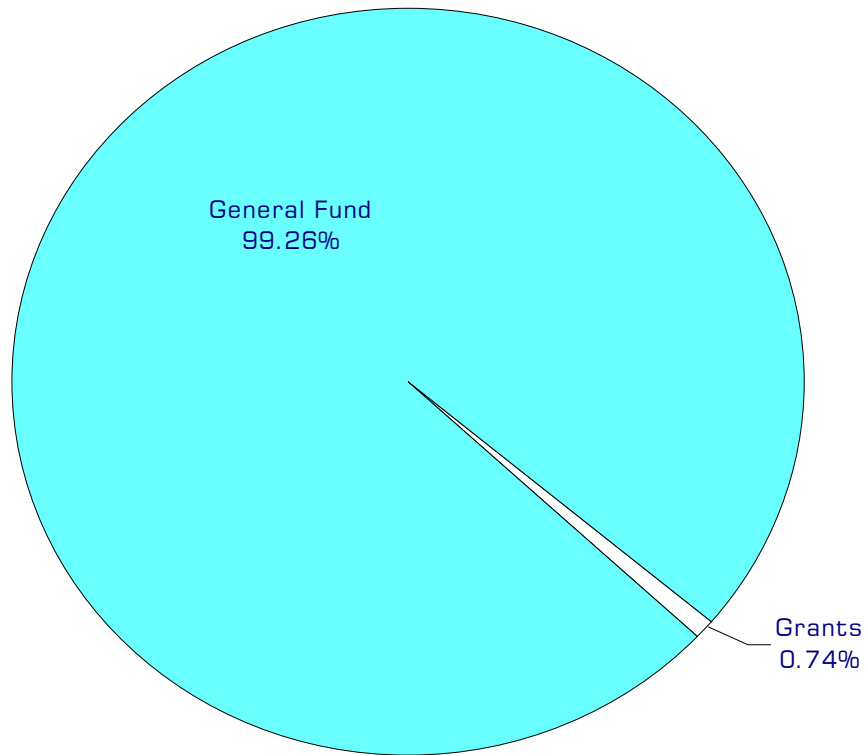

Performance / Activity Measures

	Actual 2001	Actual 2002	Actual 2003	Projected 2004	Projected 2005	Projected 2006
Felonies	1,193	1,431	1,524	1,555	1,600	1,650
Probation Violations (Sup/Dist Cts)	757	466	315	270	280	300
Misdemeanors	1,211	1,305	1,479	1,736	1,850	2,000
Juvenile (Delinquency)	987	961	939	790	800	900
Juvenile (Probation)	791	692	749	790	800	800
Juvenile (Dependency)	139	137	213	310	350	400
Mental/Alcohol Commitments	235	225	209	300	400	400
Appeals/Other	24	49	63	55	60	60
Total	5,337	5,266	5,492	5,806	6,140	6,510

Expenditures Summary

	Actual 2001	Actual 2002	Actual 2003	Budget 2004	Budget 2005	Budget 2006
GENERAL FUND						
2650 Public Defender						
Salaries & Wages	1,174,566	1,355,826	1,450,756	1,538,574	1,644,170	1,718,665
Benefits	320,360	324,540	340,397	401,872	484,336	558,210
Supplies	36,155	32,384	35,852	41,305	49,054	43,551
Other Services & Charges	287,139	295,359	307,310	300,857	310,767	318,298
Capital Outlay	4,836	-	-	-	-	8,937
Operating Transfers	15,692	-	-	-	-	-
<i>Total Public Defender</i>	<i>1,838,748</i>	<i>2,008,109</i>	<i>2,134,315</i>	<i>2,282,608</i>	<i>2,488,327</i>	<i>2,647,661</i>
<i>Percent Change from Previous Year</i>	<i>4.9%</i>	<i>9.2%</i>	<i>6.3%</i>	<i>6.9%</i>	<i>9.0%</i>	<i>6.4%</i>
2655 Public Defender-Kinney						
Salaries & Wages	150,118	-	-	-	-	-
Benefits	35,442	-	-	-	-	-
Supplies	4,699	-	-	-	-	-
Other Services & Charges	55,517	6,843	-	-	-	-
Capital Outlay	10,168	-	-	-	-	-
Operating Transfers	1,457	-	-	-	-	-
<i>Total Public Defender-Kinney</i>	<i>257,401</i>	<i>6,843</i>	<i>-</i>	<i>-</i>	<i>-</i>	<i>-</i>
<i>Percent Change from Previous Year</i>	<i>0.0%</i>	<i>-97.3%</i>	<i>-100.0%</i>	<i>0.0%</i>	<i>0.0%</i>	<i>0.0%</i>
TOTAL PUBLIC DEFENDER	2,096,149	2,014,952	2,134,315	2,282,608	2,488,327	2,647,661
<i>Percent Change from Previous Year</i>	<i>19.5%</i>	<i>-3.9%</i>	<i>5.9%</i>	<i>6.9%</i>	<i>9.0%</i>	<i>6.4%</i>

Services

Public Defender

Provides criminal defense for indigents in Whatcom County, and representation for parents in dependency cases and for individuals undergoing involuntary mental health and alcohol commitment proceedings.



Public Works Department

The largest of Whatcom County departments, Public Works' primary objective is to maintain the integrity of the Whatcom County road system in an efficient, cost effective manner that provides safe travel for the public. This is accomplished through the work of several divisions: Engineering, Equipment Rental and Replacement and Maintenance and Operations. Public Works provides year-round ferry service to Lummi Island, as well as flood control, solid waste management, and noxious weed control for the county.

FTE's for this department

Year	2001	2002	2003	*2004	*2005	*2006	<i>*budget</i>
FTE	154.00	155.00	153.00	155.00	155.50	155.50	

The chart below shows the organizational structure for 2005 only.

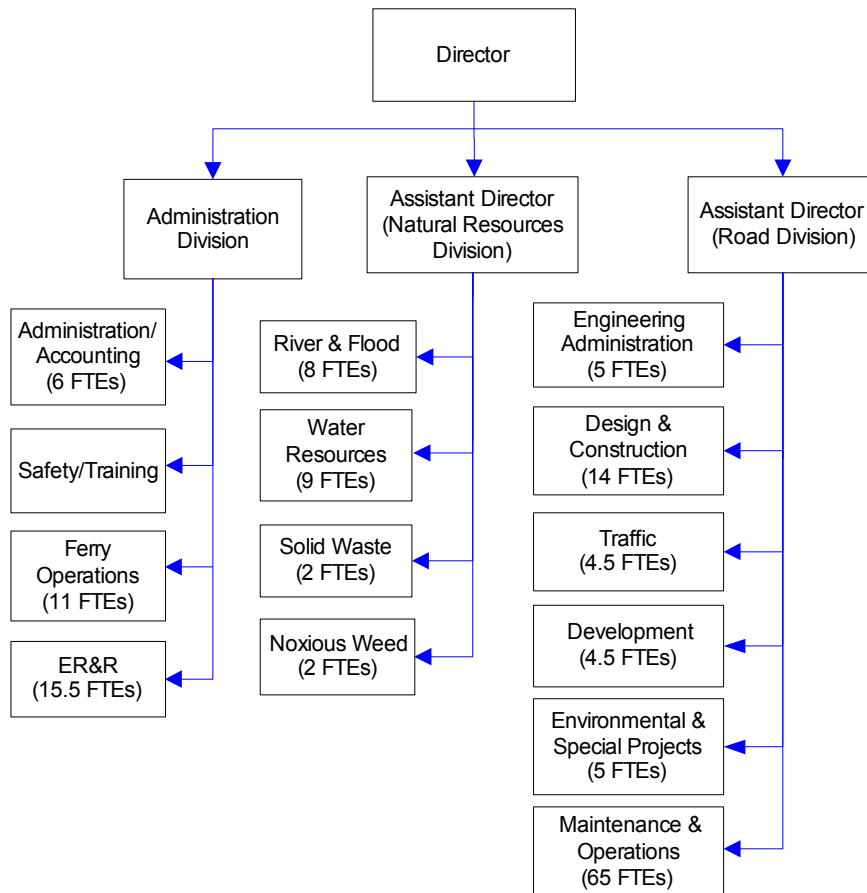

Mission & Objectives

Mission

Admin/Accounting/Safety & Training

Support and serve divisions and staff of the Public Works Department to ensure Public Works services carry out the long-term intentions of the County Executive and the County Council.

Provide timely and accurate financial information to Public Works Department managers, County Council, County Executive, other county departments, other governmental agencies, and the general public.

Supply essential support services such as payroll, accounts payable, accounts receivable, and grants management to Public Works divisions. Ensure regulatory compliance with all occupational and health standards throughout the various divisions and individual workgroups within Public Works and track possible changes to work place safety practices.

Present and document mandatory occupational safety training, and facilitate the development of employee training programs through internal and external training opportunities.

Engineering

Provide accurate information related to roads, surveys, subdivisions, and drainage in an efficient, courteous, and professional manner. Design and administer the construction of roads and bridges in an efficient and cost effective manner in accordance with all governing regulations. Enhance the safety of the public utilizing county roads. Ensure that citizens of Whatcom County receive maximum return on their tax dollars by securing state and federal funding. Improve safety of county roads through

accident investigation and operational studies.

Provide vital data for prioritization of county road maintenance and construction through the implementation and maintenance of a pavement management system.

Ensure the adequacy of infrastructure and drainage related to development activity in Whatcom County.

Equipment Services

Provide a professional and competitive equipment maintenance and replacement program to support the work and ensure the safety of county employees utilizing these services. Furnish professional and competitive procurement services to the Public Works Department.

Ferry & Docks

Transport vehicles and passengers between Lummi Island and Gooseberry Point in a safe, efficient, reliable, and convenient manner 365 days a year. Provide prompt response for emergency ferry service.

Flood Control Zone District

Plan and implement an effective, ongoing, economical, and environmentally responsible county-wide flood hazard management program.

Maintenance & Operations

Maintain the Whatcom County road system in a cost-effective, environmentally conscious manner using current technology to provide safe, efficient, and enjoyable travel for the public. Provide outstanding customer service by utilizing highly trained, service-oriented staff.

Mission & Objectives continued

Noxious Weed

Promote responsible land stewardship with regard to the degrading impacts caused by exotic pest plants. Provide current information related to management methods, prevention, and distribution of plant species in Whatcom County. Respond to citizen complaints and gain cooperation from landowners while addressing mandated duties.

Solid Waste

Facilitate an economically efficient waste prevention, recycling, and disposal system that protects human health and the environment for the citizens of Whatcom County. Assure compliance with local, state, and federal regulations pertaining to solid waste.

Water Resources

Support County Road and Flood Control Zone District programs by providing an effective water management structure that performs coordination of local, state, federal, and tribal efforts that support diverse needs and users, and promotes efficient use of available water resources. Provide technical water resource services so that county water resource stakeholders can make informed decisions.

Objectives

Administration/Accounting

- Implement selected financial related organizational changes needed to implement stormwater management priorities, including NPDES Phase II permit requirements.
- Implement administrative adjustments needed to implement and sustain GIS, MMS, and other electronic data management programs.

Safety and Training

- Conduct all required county, state, and federally related employee training as it relates to safety in the workplace.
- Conduct defensive driving training for all Whatcom County employees driving fleet vehicles. Ensure no less than twenty-five percent of all drivers receive this training during the budget year.
- Pending appropriate permitting and administrative actions, move the Safety and Training Office to 895 West Smith Road. This enhanced site will include an in-house computer applications platform. In addition, based upon permitting, develop a field training site for the introduction and familiarization of heavy equipment operations.
- Complete the comprehensive employee training guide book that will enable new and existing employees to determine required and available training opportunities that will relate to specific field assignments and job titles. The guide will cover specific training certifications, licenses, internal and external training opportunities, and work processes related to safety in the field. It will also outline required personal protective equipment and special cautions by assignment. Additionally, the guide will show sequential pictures of the specific phases of road work.
- Host a Road Crew Best Management Practices workshop in the field. The workshop will focus on roadside work that is directly or indirectly impacting fish-bearing waters and how to ensure compliance with state and federal mandates.

Objectives continued

Engineering Administration

- Complete construction and operational implementation of One-Stop Permit Center (2005-2006).
- Upgrade county Public Works web page to include road development standards (2005).
- Upgrade county Public Works web page with "One Stop" button linking Public Works Engineering, Public Works Natural Resources, Planning and Development Services, and Health Departments (2005-2006).
- Implement Maintenance Management System (MMS) customer service and call tracking ability in coordination with Maintenance and Operations MMS implementation (2005).
- Evaluate initial year of "One-Stop" operation and propose and implement organizational adjustments to address selected improvements (2006).
- Implement recommended GIS related actions, including acquisition of new county-wide aerial photographs (2006).

Engineering Design/Construction

- Plan, implement, and oversee completion of at least 75% of the Annual Road Construction Program (for both 2005 and 2006).
- Inspect the City of Lynden's bridges, per current 2003 Interlocal Agreement. This amounts to approximately 10 bridges every two (2) years and entails performing routine bridge inspections, completing the State Bridge Inspection forms, submitting to the state, providing Lynden with written notification of any deficiencies or maintenance uncovered during the

inspections, and providing funding guidance on Bridge Replacement Advisory Committee (BRAC) submittals if needed (2005 & 2006).

- Provide the Maintenance and Operations Division's Bridge Crew with a redesigned county bridge girder in the 30 and 40 foot length that is utilized on local access roads and can be installed by county forces. It is anticipated that half the work will be accomplished in 2005 and half in 2006.

Engineering Development

- Complete the comparison of the Whatcom County Development Standards (Chapter 2) pertaining to stormwater with the 2001 DOE manual and adopt adjustments as needed. Review and update low impact development designs for stormwater within Chapter 2 guidelines (2005 and 2006).
- Recommend adoption and implement a Transportation Impact Fee Ordinance (2005).
- Develop and implement cross training of Development Staff to improve operation of the One-Stop permit center, focusing on staff consistency and efficiency (2005 and 2006).
- Complete review and recommend adoption of amendments to the Trail Permit (2005).

Engineering Environmental

- Complete countywide culvert inventory, including private land (third year of a three-year program) (2005).
- Design, permit, and construct County Road Project (CRP) for resolution of the Innis Creek Road flooding/fish habitat issue (2005).
- Design, permit, and construct CRP for replacement of the Hillsdale Road/Silver

Objectives continued

Beach Creek culvert, including design of alternatives for stormwater retrofit for the Brownsville subdivision (2005).

- Design, permit, and construct CRP for the realignment of Mosquito Lake Road south of Porter Creek (2005).
- Complete the road related stormwater system inventory for all areas south of Pole Road/Grandview Road (2005). Complete the road-related stormwater system inventory for the entire county (2006).
- Complete research and recovery of monuments in two additional township and range blocks (2005 and 2006).
- Complete monitoring, maintenance, and reporting requirements for all five county-owned wetland mitigation sites (2005 and 2006).

Engineering Traffic

- During 2005, prioritize the safe-walk route proposals received from the school districts. Initiate work during 2006 of the selected capital improvement and maintenance needs of identified routes (2005 and 2006).
- Assist in the review and implementation of adjustments to the traffic signing and pavement marking inventories, as a part of implementation of a maintenance management system (2005 and 2006).
- Implement the conversion of County Road Information System (CRIS) to the new software MOBILITY. Ensure implementation is consistent with MMS development priorities (2005).
- During 2005, investigate technologies available to replace the pavement condition

“Road Rater” and recommend action. During 2006, acquire and implement new technology.

Equipment Services

- Prepare passenger vehicle and pickup truck bids, beginning December 1 of each year, to meet the 2005 and 2006 vehicle ordering cutoff date (approximately the end of March of each year).
- Once approved, develop budget proposal to implement the Master Facilities Plan for upgrading the Central Shop (2005).
- Implement outside rental source for motor pool cars by the end of 2005.

Ferry & Docks

- Implement priority portions of the adopted 20-year ferry plan. Finalize capital financing plan (2005).
- During 2005, design and recommend implementation of an off-boat ticketing system, including schedule information, ticketing and cash handling.
- Amend the Gooseberry Point parking lease with Lummi Nation to extend the expiration date and to implement a joint security camera monitoring system (2005).
- Implement an enhanced training program for the ferry crew in response to the adopted 20-year ferry plan (2005 and 2006).

Flood Control Zone District

- Complete formal adoption of revised Flood Damage Prevention Ordinance in early 2005.
- Work with Advisory Committee, Nooksack River International Task Force and Board of Supervisors to confirm the selected alternative for the flow split at Everson and

Objectives continued

- develop recommendations for action.
- Develop prioritized list of flood hazard reduction projects for Reaches 1 and 2 (downstream of the Guide-Meridian) in 2005 and Reaches 3 and 4 (upstream of Guide-Meridian) in 2006.
- Complete technical studies for Nooksack River sediment management strategy in 2005 and develop plan and begin implementation in 2006.
- Perform alternatives analyses of flood hazard reduction projects in Reaches 3 and 4 (Deming to Guide Meridian) in 2005.
- Implement acquisition project on Jones Creek as part of overall management strategy in 2005.
- Develop and implement gaging methodology to monitor bed movement and enable better estimation of inflows to the Lower Nooksack River near Deming.
- Develop recommendation for long-term implementation of flood hazard reduction projects on Swift Creek, based on alternatives in management plan in 2005.
- Implement design and construction of prioritized projects under the Flood Control Repair & Maintenance Program in 2005 and 2006.
- Develop hydraulic model for the South Fork Nooksack River in 2005.
- Monitor Saar Creek and work with Drainage Improvement District #15 and the Washington Department of Fish and Wildlife to adapt management as needed (2005 and 2006).
- Provide technical assistance to the Whatcom Land Trust to develop and analyze alternatives

to improve fish passage on Canyon Creek in 2005 for implementation in 2006.

- Evaluate Johnson Creek after completion of Phase 2 work in 2004, and perform spot maintenance as needed in 2005.

Maintenance & Operations

- Assess the existing organizational structure and work-flow processes in place at Maintenance and Operations, formulate recommendations for improvement, and implement desired changes in order to facilitate the implementation of a Maintenance Management Software System (2005 and 2006).
- Implement a Maintenance Management Software System that meets or exceeds the requirements promulgated by the County Road Administration Board (CRAB) and as mandated by CRAB to be eligible for a Certificate of Good Practice (2005 thru 2007).
- Implement an environmentally-friendly, liquid anti-icing program for roads in sensitive watersheds, eliminating the programmatic use of sand and salt as a means to control ice on roads (2005).
- Collect performance-related data such as road cleaning production rates, repair costs, and quantity of waste collected for the newly-acquired regenerative air sweeper services in order to obtain the information needed to design a comprehensive street cleaning program that meets the permit requirements for NPDES II (2005).

Noxious Weed

- Complete any necessary enforcement

Objectives continued

activities, as outlined in RCW 17.10, for any target weed(s) as designated by the Board for 2005 and 2006.

- Contact landowners and monitor sites of all documented infestations of target weed(s) as designated by the Noxious Weed Board for 2005 and 2006.
- Address citizen complaints and requests for information regarding listed noxious weeds in a timely manner.
- Evaluate progress on publicly owned travel corridors and review management practices on an ongoing basis.
- Evaluate progress on each documented weed site and record compliance to improve landowner communication.
- Provide a minimum of ten public presentations or exhibits.
- Plan and participate in multi-agency weed removal projects in natural areas.
- Participate in multi-agency riparian projects that include research on plant management methods and salmon habitat restoration efforts.

Solid Waste

- Implement two Moderate Risk Waste outside collection events and achieve growth of the EnviroStars Program with two new business participants each year.
- Complete draft copy of new Solid Waste Comprehensive Management Plan in 2005 and seek adoption.
- Develop incentives for curbside yard waste recycling and evaluate the existing waste stream in order to identify future needs and management recommendation.

- Reimplement a Local Grant Program for innovative recycling and other solid waste management projects.
- Evaluate the EPA investigation report for the Y Road Landfill and propose a long-term management strategy for the site.
- Implement an Earth Day countywide garage sale event, registering 600 participants in 2005 and 650 in 2006.

Water Resources

- Identify and recommend resources needed to implement activities required by the National Pollution Discharge Elimination System (NPDES) Phase II permit (2005-2006).
- Review annual Road and Flood Control District projects lists and identify salmon recovery opportunities that enhance these projects (2005-2006).
- Work with Planning and Development Services to identify changes to the critical areas ordinance and shoreline master program that are needed in order to support salmon recovery efforts in Whatcom County (2005-2006).
- Develop and implement a public involvement and education program that meets NPDES Phase II Stormwater requirements (2005-2006).
- Identify Lake Whatcom priority drainages for the evaluation of appropriate stormwater best management practices (2005).
- Complete draft of the WRIA 1 long-term monitoring plan (2005).
- Identify and recommend a long-term tributary monitoring strategy for the Lake Whatcom watershed (2005-2006).

Expenditure Trends

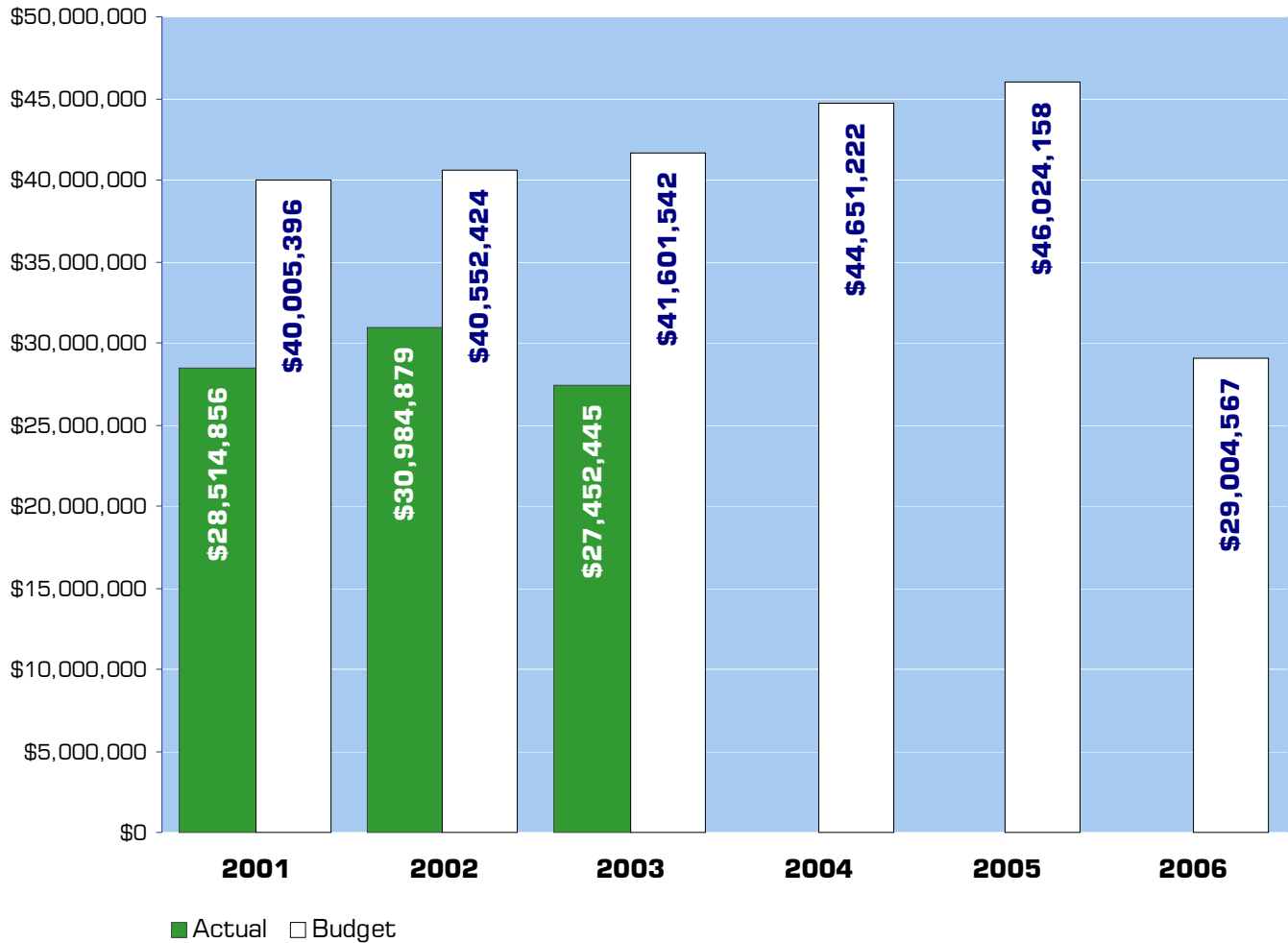

NOTE: To accurately reflect operational cost, graph includes road construction. Other capital expenditures, such as equipment purchases are not shown. Operating transfers have also been eliminated to avoid double accounting.

2005-2006 Budget by Program

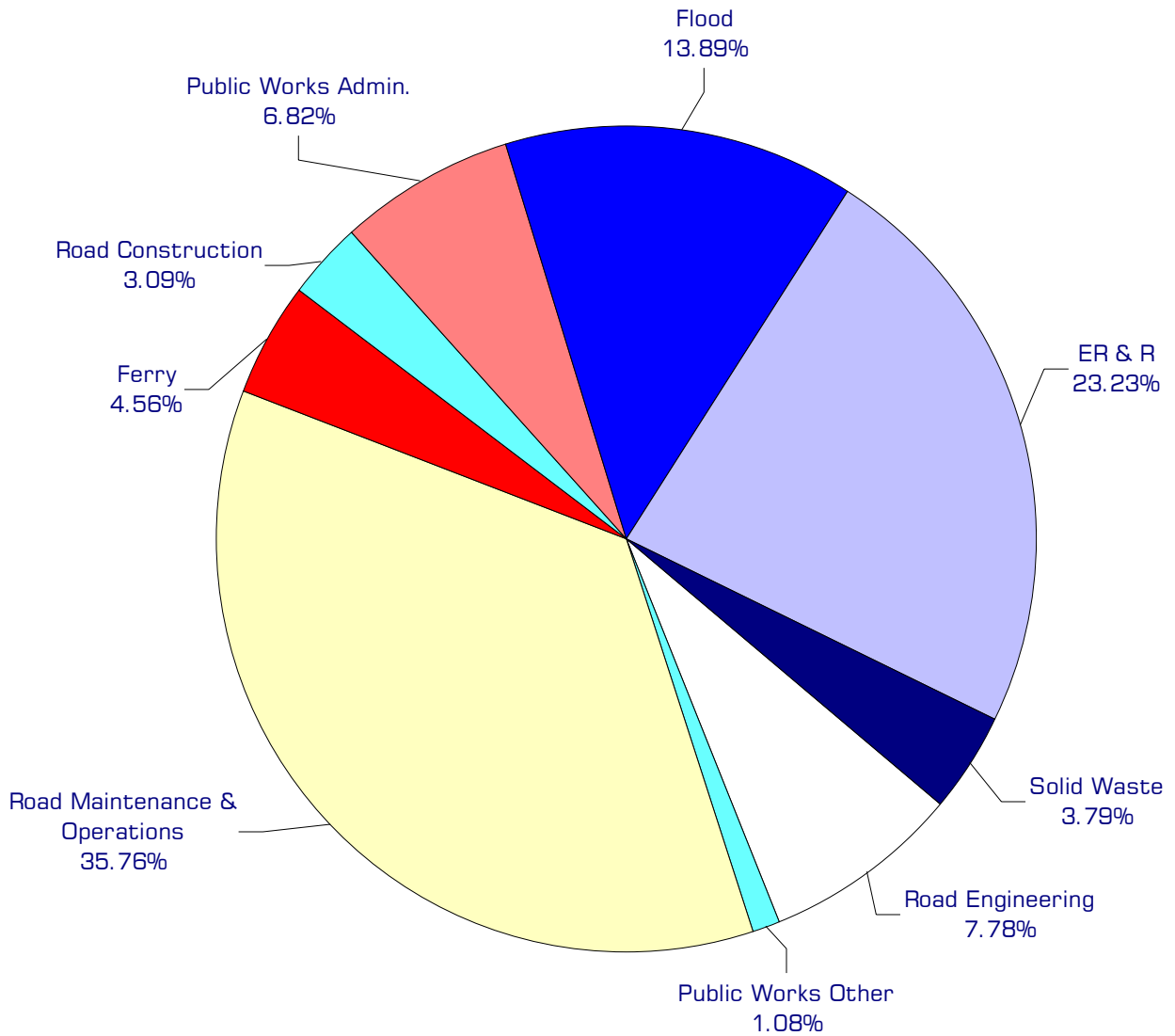

NOTE: To accurately reflect operational cost, graph includes road construction. Other capital expenditures such as equipment purchases are not shown. Operating transfers have also been eliminated to avoid double accounting. "Public Works Other" includes CERB Fund, Road Improvement Districts, Pt. Roberts Fuel Tax Fund, Lake Management District, Sewer Construction Fund and LRID #10 Construction Fund.

Program Summary

	Actual 2001	Actual 2002	Actual 2003	Budget 2004	Budget 2005	Budget 2006
OPERATIONS						
Public Works						
Public Works Admin	1,917,402	1,551,596	1,677,371	1,914,717	2,077,386	2,055,797
Road Engineering	1,497,644	1,627,933	1,770,693	2,728,744	2,344,833	2,366,481
Road M & O	9,133,538	9,821,219	9,810,277	10,827,793	10,752,036	10,905,857
Ferry	1,140,182	1,235,581	1,248,651	1,322,128	1,347,225	1,412,344
Road Construction	1,130,756	1,121,675	1,186,107	1,478,984	1,006,671	864,036
Flood Control Zone	1,502,143	2,176,592	2,180,122	5,505,432	4,776,169	3,638,788
Public Works Other	70,681	63,678	52,137	274,850	324,639	329,599
ER & R	2,940,052	3,742,057	3,061,388	6,485,420	7,764,107	6,308,332
Solid Waste	924,209	930,733	865,101	1,206,409	1,174,092	1,123,333
Water Resources	1,960,896	3,072,271	2,464,352	728,820	-	-
<i>Total PW Operations</i>	<i>22,217,503</i>	<i>25,343,335</i>	<i>24,316,199</i>	<i>32,473,297</i>	<i>31,567,158</i>	<i>29,004,567</i>
CAPITAL						
Public Works						
Public Works Admin	100,675	20,332	223,610	-	23,750	-
Road Engineering	91,151	-	41,170	-	13,000	-
Ferry	-	-	-	-	100,000	-
Road M & O	56,139	10,432	8,688	4,000	218,500	-
Road Construction	6,297,353	5,641,544	3,136,246	12,177,925	14,457,000	-
Flood Control Zone	318,034	301,571	347,374	334,114	350,000	-
Public Works Other	-	-	4,943	-	-	-
ER & R	1,474,918	1,484,138	1,562,543	2,938,960	2,058,500	1,363,000
Solid Waste	1,213	-	-	-	-	-
Water Resources	26,049	-	3,924	-	-	-
<i>*Total PW Capital</i>	<i>8,365,532</i>	<i>7,458,017</i>	<i>5,328,498</i>	<i>15,454,999</i>	<i>17,220,750</i>	<i>1,363,000</i>
TRANSFERS						
Public Works						
Public Works Administration	175,810	269,405	225,922	170,167	219,009	191,924
Road Engineering	21,786	61,522	66,531	9,925	27,770	26,940
Road M & O	109,522	126,474	91,182	418,340	70,128	74,170
Ferry	5,793	-	81,049	-	-	-
Flood Control Zone	2,015,344	3,329,338	2,769,476	232,785	307,970	154,120
Public Works Other	265,523	322,712	169,388	223,902	304,135	190,400
ER & R	12,662	40,033	-	-	6,350	3,600
Solid Waste	141,934	147,045	111,136	113,293	113,293	113,293
Water Resources	264,848	176,903	263,196	-	-	-
<i>Total PW Transfers</i>	<i>3,013,222</i>	<i>4,473,432</i>	<i>3,777,880</i>	<i>1,168,412</i>	<i>1,048,655</i>	<i>754,447</i>
TOTAL PUBLIC WORKS	33,596,257	37,274,784	33,422,577	49,096,708	49,836,563	31,122,014
<i>Percent Change from Previous Year</i>	<i>7.1%</i>	<i>10.9%</i>	<i>-10.3%</i>	<i>46.9%</i>	<i>1.5%</i>	<i>-37.6%</i>

* In 2006, Whatcom County will begin project-by-project budgeting for major construction projects as they are adopted by the County Council.

2005-2006 Funding Sources

	2005	2006
Property Tax - Road & Flood	15,414,000	15,797,000
Other Taxes	386,783	386,783
Equip Rental - ER&R	4,310,529	4,510,225
Material Sales - ER&R	2,985,000	3,010,000
Charges for Service	1,590,228	1,588,728
Miscellaneous Revenue	91,042	91,042
Intergovt'l Revenue	8,377,603	1,997,975
Fuel Tax	3,545,200	3,651,556
Timber Sales	900,000	900,000
Operating Transfers	522,600	522,747
Residual Equity Transfers	79,800	5,500
*Fund Balance	(6,535,627)	(3,456,989)
Total Funding	31,667,158	29,004,567

Property Tax - Roads & Flood

The county road district levies a property tax of approximately two dollars per thousand dollars of assessed value. This revenue is dedicated to construction, maintenance and administration of county roads. The county flood district levies a property tax of approximately twenty cents per thousand dollars of assessed value. This revenue is dedicated to flood hazard management in Whatcom County.

continued on next page

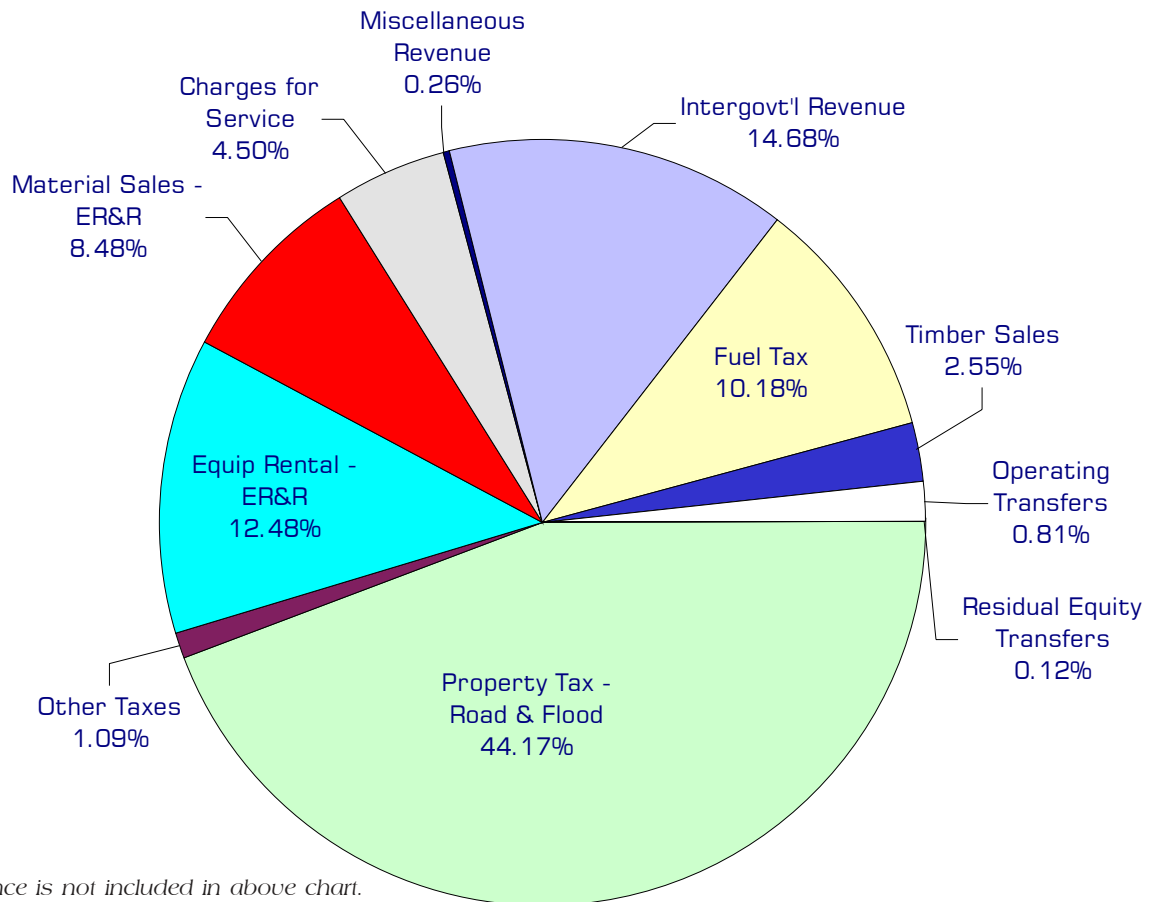

*Fund Balance is not included in above chart.

Funding Sources continued

Other Taxes

Public Works receives revenues from Timber Harvest Taxes and various excise taxes specifically for the funding of roads programs, per RCW 84.33.080.

Equipment Rental - ER&R

Interfund charges for rental of vehicles and equipment. Charges are set to recover operational costs and provide for replacement.

Material Sales - ER&R

Interfund sales of primarily road materials to the road fund.

Charges for Service

The department charges for various services it provides. Examples include cost sharing agreements with property owners for flood control projects, ferry toll for the Lummi Island ferry and sales of maps and publications. Solid waste surcharges collected at disposal facilities in the county are included in this line.

Miscellaneous Revenue

The department receives small amounts of revenue from various sources such as licenses and permits.

Intergovernmental Revenue

Public Works receives funds from a number of federal and state grants for road construction, flood control projects and bridge replacement. Also included are Federal Forest funds (per RCW 36.33.110) which are to be used for road purposes and operating subsidy from the state for operation to the Lummi Island ferry (per RCW 47.56.725).

Fuel Tax

The Road Fund receives a portion of the state gas tax which is distributed to the counties based on a formula as specified in RCW 46.68.100.

Timber Sales

State timber sales on county land deeded to Department of Natural Resources as provided by RCW 76.12.030.

Operating Transfers

Funding from the General Fund in support of the Noxious Weed Program for \$70,000 per year; Lake Whatcom Management for \$100,000 per year; \$155,000 per year for Marine Resources Support; and approximately \$7,200 per year for clerical support to the special projects manager. Funding from Road Improvement District #9 for payments due to the Community Economic Revitalization Board loan of \$189,360 per year.

Residual Equity Transfers

Funds transferred in to the Equipment Rental & Revolving Fund for the purchase of vehicles on behalf of the General Fund.

Fund Balance

Budgeted revenues exceed budgeted operating expenditures by \$6,324,851 in 2005 and \$3,231,213 in 2006, for all of Public Works' various funds.

Performance / Activity Measures

	Actual 2001	Actual 2002	Actual 2003	Projected 2004	Projected 2005	Projected 2006
<i>Administration</i>						
<i>Safety & Training</i>						
Conduct mandatory and recommended safety training as follows:						
First Aid, CPR and Bloodborne Pathogens training	72	75	60	60	30	40
Flagger Certification course	20	25	11	30	9	20
Forklift Certification course	18	20	7	10	10	10
Hazardous Materials Awareness training	60	60	11	20	15	30
Hazardous Materials Operations training	10	12	-	6	3	3
Pilot/Escort Certification	22	25	20	10	5	5
Defensive Driving Course within Public Works	36	40	15	30	34	14
Defensive Driving Course in other departments	36	45	32	60	60	60
Fall Protection training	10	15	12	12	12	12
Sandbag Operations	60	65	71	65	65	65
Endangered Species Act training (ESA)		60	5	80	60	10
Conduct Public Works new employee and summer help safety orientations	25	30	13	20	16	16
<i>Engineering Design/Const</i>						
Total construction expenditures	\$ 7,432,000	\$ 6,767,000	\$ 7,385,000	\$ 7,046,400	\$10,200,000	\$ 8,000,000
Cost of right of way acquisitions	\$ 300,000	\$ 250,000	\$ 200,000	\$ 300,000	\$ 600,000	\$ 600,000
<i>Engineering Development</i>						
Long Plats	15	11	4	6	6	6
Short Plats, Lot Line Adjust., Lot Consolidation	54	38	42	100	110	120
Variances	31	5	5	5	6	6
Planned Unit Development	5	7	1	2	2	2
Shoreline - Development	21	25	8	18	20	22
Shoreline - Variances	16	25	7	5	6	7
Shoreline - Conditional Use	21	25	7	9	10	12
Commercial Building	110	127	159	150	160	160
Accessory Dwelling Units	45	54	47	45	50	50
Conditional Use	71	70	25	30	35	35
Binding Site Plans	4	4	2	2	2	2

continued on next page

Performance / Activity Measures continued

	Actual 2001	Actual 2002	Actual 2003	Projected 2004	Projected 2005	Projected 2006
Address Assignment	1,019	890	1,044	900	950	1,000
Long Plat Addressing (number of plats)	15	11	4	5	7	6
Short Plat Addressing (number of plats)	51	85	85	90	110	120
Address Changes/Corrections	100	254	368	150	250	250
Road Name Projects	41	50	35	35	40	40
Trail Permits	15	15	28	30	30	30
Latecomers	3	1	2	1	2	2
Exemptions (including gifts)	70	80	109	100	60	50
Other exemptions (i.e. LLA, BLA)	125	175	80	60	40	40
<i>Engineering Traffic</i>						
Traffic Accidents	592	639	650	675	650	650
Traffic Accidents - Investigated	21	24	30	40	45	50
Traffic Counts Conducted	168	176	225	225	250	250
Revocable Encroachment Permits	1,061	1,071	1,100	1,050	1,025	1,050
<i>Environmental & Special Projects</i>						
Construction expenditures managed	NA	\$ 42,000	\$ 280,000	\$ 1,245,980	\$ 1,000,000	\$ 1,000,000
Professional services expenditures managed	NA	NA	\$ 300,000	\$ 410,000	\$ 220,000	\$ 200,000
Number of permits obtained for Engineering and M&O	62	61	129	145	150	155
Cumulative number of monuments entered into GIS database	NA	NA	600	1,200	1,400	1,600
Cumulative number of public and private drainage structures inventoried	900	2,000	2,800	20,000	22,000	24,000
<i>Equipment Services</i>						
Purchase of Supplies:						
Asphalt (tons)	8,500	9,648	8,000	2,500	10,500	10,500
CRS2 Road Oil (tons)	2,738	2,438	2,478	3,000	2,500	2,500
Striping Paint (gallons)	36,180	32,700	33,500	32,000	33,000	34,000
Signs	3,700	3,433	2,600	3,000	2,700	2,800
Sign Posts	1,000	685	792	800	800	900
Rip Rap Rock (tons)	19,764	13,589	27,878	25,000	27,000	27,000
Outsourced Work:						
Auto Glass	\$ 8,500	\$ 17,218	\$ 11,412	\$ 12,500	\$ 15,000	\$ 15,000
Auto Body Work	\$ 20,000	\$ 31,000	\$ 51,361	\$ 40,000	\$ 50,000	\$ 55,000
County Fleet Fuel Cost:						
Diesel Fuel	\$ 115,000	\$ 137,000	\$ 125,402	\$ 155,000	\$ 160,000	\$ 165,000
Unleaded Fuel	\$ 235,000	\$ 219,000	\$ 271,996	\$ 295,000	\$ 300,000	\$ 310,000

continued on next page

Performance / Activity Measures continued

	Actual 2001	Actual 2002	Actual 2003	Projected 2004	Projected 2005	Projected 2006
Fleet Services:						
Preventative Maintenance & Service	1,300	1,300	1,355	1,375	1,400	1,500
Tire Jobs (in house only)	1,025	620	372	400	450	450
Brake Jobs	393	403	443	445	450	450
Equipment / Vehicles Purchased	47	47	52	48	50	55
<i>Ferry & Docks</i>						
Passengers (including drivers)	223,839	227,524	227,282	230,000	240,000	240,000
Vehicles (cars, trucks, cycles, bicycles)	143,603	134,203	136,441	135,000	137,000	138,000
Ferry Diesel Costs	\$ 50,947	\$ 45,870	\$ 55,556	\$ 60,000	\$ 65,000	\$ 70,000
<i>Flood Control Zone District</i>						
NFIP Flood Permits Issued	105	127	115	110	120	120
Flood Inquiries	168	224	234	400	250	250
Community Rating (Range 10-1 High-Low Flood Ins)	7	7	7	7	6	6
Ongoing planning projects	6	7	5	6	2	2
Completed planning projects	1	1	2	3	6	2
Ongoing repair & maintenance projects	10	4	11	6	5	5
Completed repair & maintenance projects	5	12	13	11	5	5
Ongoing flood hazard reduction projects	6	3	1	1	1	1
Completed flood hazard reduction projects	3	1	3	4	4	4
Ongoing monitoring projects	6	6	6	5	4	3
<i>Maintenance & Operations</i>						
Miles of paved county roads	891	896	901	905	910	914
Miles of gravel & dirt county roads	58	55	50	45	41	37
Major repair projects on bridges	4	4	4	4	3	3
Lane miles of paint striping	1,600	1,907	2,000	1,800	1,800	1,800
Signs maintained	8,100	8,300	8,500	8,800	9,000	9,200
Centerline miles of chip sealing completed	100	100	97	100	100	100
<i>Noxious Weed</i>						
Landowner contacts	4,100	4,100	4,400	5,000	5,100	5,300
Requests for information	4,300	4,600	4,800	5,100	5,300	5,500
"Request Action" notices sent	320	314	350	370	345	380
Enforcement cases	6	-	-	4	3	4
Imposed Fees (\$)	1,200	-	-	800	600	800
Estimated landowner compliance	42%	46%	50%	43%	46%	48%
Parcels in database	650	663	655	645	650	655

Performance / Activity Measures continued

	Actual 2001	Actual 2002	Actual 2003	Projected 2004	Projected 2005	Projected 2006
<i>Solid Waste</i>						
Pounds of Household Hazardous Waste processed at D.O.T.	325,000	402,090	428,000	400,000	425,000	440,000
Recycling hotline calls	4,800	4,334	5,991	4,800	6,000	6,500
Students receiving classroom presentations	6,500	7,873	7,422	8,000	8,000	8,000
Pounds of litter picked up in W.C.	240,000	51,214	67,470	75,000	70,000	65,000
Tons of materials recycled and/or diverted (DOE data)	142,760	168,446	140,000	150,000	150,000	150,000
Garage Sale households	768	587	688	600	650	675
<i>Water Resources</i>						
Marine Resources Projects completed					10	13
Public Workshops, Seminars and training events					20	22
Water Resources Data and Information Requests					150	175
County projects that support salmon recovery					18	20

Expenditures Summary

	Actual 2001	Actual 2002	Actual 2003	Budget 2004	Budget 2005	Budget 2006
Public Works Administration						
Salaries & Wages	407,473	408,594	366,098	466,326	554,367	548,165
Benefits	395,067	92,923	218,309	280,721	321,481	296,009
Supplies	62,550	25,856	21,222	43,050	48,450	40,750
Other Services & Charges	1,051,611	1,023,406	1,070,892	1,123,620	1,152,088	1,169,873
Intergov Services & Charge	701	817	850	1,000	1,000	1,000
Capital Outlay	100,675	20,332	223,610	-	23,750	-
Operating Transfers	175,810	269,405	225,922	170,167	219,009	191,924
Total Administration	2,193,887	1,841,333	2,126,903	2,084,884	2,320,145	2,247,721
<i>Percent Change from Previous Year</i>	7.6%	-16.1%	15.5%	-2.0%	11.3%	-3.1%
Road Engineering						
Salaries & Wages	727,585	820,426	947,838	1,142,572	1,068,014	1,112,817
Benefits	387,396	433,303	483,763	620,696	576,323	597,168
Supplies	115,271	52,702	50,225	96,645	94,300	80,050
Other Services & Charges	266,655	320,739	288,057	822,581	605,196	575,446
Intergov Services & Charge	737	763	810	46,250	1,000	1,000
Capital Outlay	91,151	-	41,170	-	13,000	-
Operating Transfers	21,786	61,522	66,531	9,925	27,770	26,940
Total Road Engineering	1,610,581	1,689,455	1,878,394	2,738,669	2,385,603	2,393,421
<i>Percent Change from Previous Year</i>	21.2%	4.9%	11.2%	45.8%	-12.9%	0.3%
Road M & O						
Salaries & Wages	2,150,079	2,139,474	2,370,952	2,504,780	2,639,614	2,739,289
Benefits	1,158,649	1,151,388	1,230,733	1,351,095	1,422,551	1,476,775
Supplies	2,595,637	2,425,063	2,454,868	2,971,910	2,759,960	2,851,684
Other Services & Charges	3,226,544	3,943,642	3,751,863	4,000,008	3,929,911	3,838,109
Intergov Services & Charge	2,629	161,652	1,861	-	-	-
Capital Outlay	56,139	10,432	8,688	4,000	218,500	-
Operating Transfers	75,365	99,391	63,160	48,340	70,128	74,170
Residual Equity Transfers	34,157	27,083	28,022	370,000	-	-
Total Road M & O	9,299,199	9,958,125	9,910,147	11,250,133	11,040,664	10,980,027
<i>Percent Change from Previous Year</i>	-3.4%	7.1%	-0.5%	13.5%	-1.9%	-0.5%
Ferry						
Salaries & Wages	442,734	461,829	489,903	466,481	517,047	566,698
Benefits	228,714	264,090	254,452	275,199	281,230	296,698
Supplies	6,210	9,480	8,785	9,000	9,000	9,000
Other Services & Charges	453,086	487,835	483,375	558,748	527,248	527,248
Intergov Services & Charge	9,438	12,347	12,136	12,700	12,700	12,700
Capital Outlay	-	-	-	-	100,000	-
Operating Transfers	5,793	-	81,049	-	-	-
Total Ferry	1,145,975	1,235,581	1,329,700	1,322,128	1,447,225	1,412,344
<i>Percent Change from Previous Year</i>	26.1%	7.8%	7.6%	-0.6%	9.5%	-2.4%

continued on next page

Expenditures Summary continued

	Actual 2001	Actual 2002	Actual 2003	Budget 2004	Budget 2005	Budget 2006
Road Construction						
Salaries & Wages	536,192	456,617	448,047	635,383	537,464	561,062
Benefits	286,848	246,060	241,765	343,109	290,232	302,974
Supplies	21,625	89,794	155,141	-	130,600	-
Other Services & Charges	109,234	275,365	328,484	500,492	48,375	-
Intergov Services & Charge	176,857	53,839	12,670	-	-	-
Capital Outlay	6,297,353	5,641,544	3,136,246	12,177,925	14,457,000	-
<i>*Total Road Construction</i>	<i>7,428,109</i>	<i>6,763,219</i>	<i>4,322,353</i>	<i>13,656,909</i>	<i>15,463,671</i>	<i>864,036</i>
<i>Percent Change from Previous Year</i>	<i>18.7%</i>	<i>-9.0%</i>	<i>-36.1%</i>	<i>216.0%</i>	<i>13.2%</i>	<i>-94.4%</i>
Flood Control Zone						
Salaries & Wages	209,925	264,751	308,021	624,929	669,565	679,155
Benefits	125,256	154,201	174,608	323,809	333,843	342,102
Supplies	176,800	232,506	86,626	178,430	388,400	277,000
Other Services & Charges	901,881	1,366,504	1,572,835	3,665,839	3,338,861	2,293,031
Intergov Services & Charge	88,281	158,630	38,032	712,425	45,500	47,500
Capital Outlay	318,034	301,571	347,374	334,114	350,000	-
Operating Transfers	1,987,273	3,329,338	2,769,476	232,785	307,970	154,120
Residual Equity Transfers	28,071	-	-	-	-	-
<i>Total Flood Control Zone</i>	<i>3,835,521</i>	<i>5,807,501</i>	<i>5,296,972</i>	<i>6,072,331</i>	<i>5,434,139</i>	<i>3,792,908</i>
<i>Percent Change from Previous Year</i>	<i>21.4%</i>	<i>51.4%</i>	<i>-8.8%</i>	<i>14.6%</i>	<i>-10.5%</i>	<i>-30.2%</i>
Public Works Other **						
Salaries & Wages	-	-	6,699	9,481	6,000	-
Benefits	-	-	3,618	5,119	3,240	-
Supplies	-	-	1,766	16,000	800	-
Other Services & Charges	70,681	63,678	40,054	244,250	314,599	329,599
Capital Outlay	-	-	4,943	-	-	-
Debt Service	177,830	312,207	168,318	109,135	189,360	189,360
Operating Transfers	87,693	10,505	1,070	114,767	114,775	1,040
<i>Total Public Works Other</i>	<i>336,204</i>	<i>386,390</i>	<i>226,468</i>	<i>498,752</i>	<i>628,774</i>	<i>519,999</i>
<i>Percent Change from Previous Year</i>	<i>55.3%</i>	<i>14.9%</i>	<i>-41.4%</i>	<i>120.2%</i>	<i>26.1%</i>	<i>-17.3%</i>
ER & R						
Salaries & Wages	1,187,382	1,220,373	1,296,278	1,380,371	1,470,227	1,513,554
Benefits	182,889	188,645	182,632	238,985	281,146	275,144
Supplies	841,979	812,524	920,590	3,550,317	3,656,000	3,712,900
Other Services & Charges	726,460	1,519,044	660,447	1,314,147	2,355,134	805,134
Intergov Services & Charge	1,342	1,471	1,441	1,600	1,600	1,600
Capital Outlay	1,474,918	1,484,138	1,562,543	2,938,960	2,058,500	1,363,000
Operating Transfers	12,662	40,033	-	-	6,350	3,600
<i>Total ER & R</i>	<i>4,427,632</i>	<i>5,266,228</i>	<i>4,623,931</i>	<i>9,424,380</i>	<i>9,828,957</i>	<i>7,674,932</i>
<i>Percent Change from Previous Year</i>	<i>6.5%</i>	<i>18.9%</i>	<i>-12.2%</i>	<i>103.8%</i>	<i>4.3%</i>	<i>-21.9%</i>

continued on next page

Expenditures Summary continued

	Actual 2001	Actual 2002	Actual 2003	Budget 2004	Budget 2005	Budget 2006
Solid Waste						
Salaries & Wages	75,578	76,691	83,293	85,736	85,856	85,976
Benefits	20,211	20,207	22,656	24,582	27,685	30,806
Supplies	38,258	33,303	41,670	54,500	50,950	50,950
Other Services & Charges	499,478	484,919	360,011	886,589	888,601	834,601
Intergov Services & Charge	290,684	315,613	357,471	155,002	121,000	121,000
Capital Outlay	1,213	-	-	-	-	-
Operating Transfers	141,934	125,980	111,136	113,293	113,293	113,293
Residual Equity Transfers	-	21,065	-	-	-	-
Total Solid Waste	1,067,356	1,077,778	976,237	1,319,702	1,287,385	1,236,626
<i>Percent Change from Previous Year</i>	<i>24.4%</i>	<i>1.0%</i>	<i>-9.4%</i>	<i>35.2%</i>	<i>-2.4%</i>	<i>-3.9%</i>
Water Resources						
Salaries & Wages	316,223	379,248	401,787	-	-	-
Benefits	83,978	171,062	164,969	-	-	-
Supplies	95,678	35,744	28,971	-	-	-
Other Services & Charges	516,970	601,467	547,587	275,120	-	-
Intergov Services & Charge	948,047	1,884,750	1,321,038	453,700	-	-
Capital Outlay	26,049	-	3,924	-	-	-
Operating Transfers	244,848	176,903	263,196	-	-	-
Residual Equity Transfers	20,000	-	-	-	-	-
***Total Water Resources	2,251,793	3,249,174	2,731,472	728,820	-	-
<i>Percent Change from Previous Year</i>	<i>-20.3%</i>	<i>44.3%</i>	<i>-15.9%</i>	<i>-73.3%</i>	<i>-100.0%</i>	<i>0.0%</i>
TOTAL PUBLIC WORKS	33,596,257	37,274,784	33,422,577	49,096,708	49,836,563	31,122,014
<i>Percent Change from Previous Year</i>	<i>7.1%</i>	<i>10.9%</i>	<i>-10.3%</i>	<i>46.9%</i>	<i>1.5%</i>	<i>-37.6%</i>

* In 2006, Whatcom County will begin project-by-project budgeting for major construction projects as they are adopted by the County Council.

** Public Works Other includes: Paths & Trails Reserve Fund, CERB Fund, Road Improvement Districts, Pt. Roberts Fuel Tax, Lake Management District, Sewer Construction Fund, LRID Construction Fund and Sub-Zone Funds.

*** With the completion of the planning phase of WR1A1 and its implementation, staff duties have been reassigned to the Road and Flood control Funds.

Services

Administration

Administration/Accounting

Public Works Administration provides centralized accounting in addition to personnel, central filing, and various reporting support activities necessary for the department.

Safety and Training

Centralized safety, training, and claims management for the Public Works Department.

Engineering Administration

Engineering Administration

Operation of Office of the County Engineer.

Records Management and Archiving

File and maintain legal records for all matters concerning public roads, highways, bridges, ditches, or other surveys, complete with the original papers, documents, petitions, surveys, repairs, and other papers.

Engineering Design/Construction

Bridge Inspection

Monitor the functional and structural integrity of county bridges through regular inspection of all county bridges. Perform same duties for municipalities if interlocals/contracts exist.

Road Construction

Design and construction of roads and bridges, including acquisition of needed right-of-way and permits. Serve as Certification Acceptance (CA) Agency for small cities and other county departments on federally funded projects.

Technical support - Survey, Engineering, Inspection

Survey and Engineering Technical Support that provides efficiency, cost savings, and customer service benefits to Maintenance and Operations Division, River and Flood Division, and other Engineering Sections.

Engineering Development

Addressing and Road Naming

Process road name and address assignments for properties and roadways in the county.

Development Review and Mitigation

Review proposed developments and construction projects affecting existing and future county public right-of-ways and transportation systems.

Engineering Environmental & Special Projects

Environmental and Special Projects

Support county road construction and maintenance activities through resolution of complex environmental, hydraulic, geotechnical, and regulatory issues.

Services continued

Engineering Traffic

Encroachment Permits

To determine applicability of WCC title 12.16 for the use of county right-of-way.

Pavement Management

Reviews county roads for condition and funding.

Traffic/Transportation Analysis

Reviews county right-of-way for transportation efficiency and safety.

Equipment Services

Equipment Rental and Maintenance

Provides acquisition of equipment and vehicle maintenance and replacement.

Central Stores

Provides professional and competitive procurement of goods and services, and maintains material inventories.

Pits & Quarries

Provides various aggregates (chip-seal rock, sand, pit-run gravel, and other materials) needed by the county road department in the performance of their duties.

Facilities

Provides building, storage, and parking space to county agencies, including the buildings at 322 N. Commercial Street and the Central Shop facility at 901 W. Smith Road along with various parcels of land.

Ferry & Docks

Ferry & Docks

Provides passenger and vehicle transportation from the mainland to Lummi Island 365 days per year. It is the only means of transportation to reach county roads on Lummi Island.

Flood Control Zone District

Flood Response

Provide annual training to staff for flood response and flood fighting. In case of a flood emergency, coordinate and perform various response functions.

Comprehensive Flood Hazard Management Planning

Comprehensive flood hazard management planning includes developing an in-depth understanding of flood causes and behaviors and evaluating/selecting flood hazard management options.

Technical Assistance

Provide flood control technical assistance in planning, design, prioritization, funding research, and permitting to special purpose districts. Also provides administrative support for special purpose districts.

Services continued

National Flood Insurance Program

Administer the National Flood Insurance Program and the Community Rating System.

Early Flood Warning System

Maintain flood warning equipment, monitor gauges during potential flooding situations, and provide warning information to the public.

Flood Control Repair & Maintenance Program

Plan, design, and oversee flood control repair and maintenance projects for the protection of public and private property.

Flood Hazard Reduction

Provide for implementation of projects resulting from comprehensive planning efforts to reduce flood damages.

Maintenance & Operations**Maintenance & Operations Administration**

Provide progressive, outcome-based, customer-centered, efficiency-oriented management and support services of Maintenance and Operations activities, both public and private, emphasizing use of training and technology.

Roadway Maintenance

Maintain the county road system by preventing, reducing or restoring deterioration of the roadway infrastructure through road surface and roadway structure management.

Structures Maintenance

Maintain the County road system by preventing, reducing or restoring deterioration of the roadway infrastructure through management of bridges and other roadway-related structures.

Surface Drainage Management

Maintain the County road system by preventing, reducing or restoring deterioration of the roadway infrastructure through management of stormwater drainage systems.

Traffic Operations

Maintain the safety of the County road system by installing and maintaining appropriate traffic control devices.

Vegetation Management

Maintain the County road system by preventing, reducing or restoring deterioration of the roadway infrastructure through roadside vegetation management.

Noxious Weed**Noxious Weed Management**

Provides information to the public regarding the management and spread of exotic pest plants (noxious weeds) and their impacts on the environment and economy.

Services continued

Solid Waste

Landfill Closure Monitoring

Monitors closed landfill sites.

General Recycling Programs

Provides education and recycling opportunities for general waste and yard waste.

Litter Control

Litter Control in Whatcom County.

Hazardous Waste Management - CPG

Provides education and recycling opportunities to separate hazardous and moderate-risk waste products from general waste.

Water Resources

Marine Resources Project and Staff Support

Preservation and restoration of Marine habitat in Whatcom County and shellfish protection and response to shellfish closures.

Project Management for WRIA Implementation Activities

Implementation of county activities identified in the WRIA Watershed Management Plan.

Salmon Recovery/ESA

County response to Endangered Species Act and salmon recovery.

Stormwater Management

Stormwater services in accordance with EPA NPDES Phase II requirements.



County Sheriff's Office

An elected official, the County Sheriff is responsible for law enforcement in the unincorporated areas of Whatcom County. The Sheriff also has several county-wide responsibilities (serving both the cities and unincorporated areas), including operating the county jail and coordinating professional and volunteer search & rescue efforts. The Sheriff's Emergency Management Division provides community education in disaster mitigation and preparedness, and plans for and coordinates disaster response and recovery efforts.

FTE's for this department

Year	2001	2002	2003	*2004	*2005	*2006
FTE	92.00	92.00	92.00	99.80	101.80	101.00

**budget*

The chart below shows the organizational structure for 2005 only.

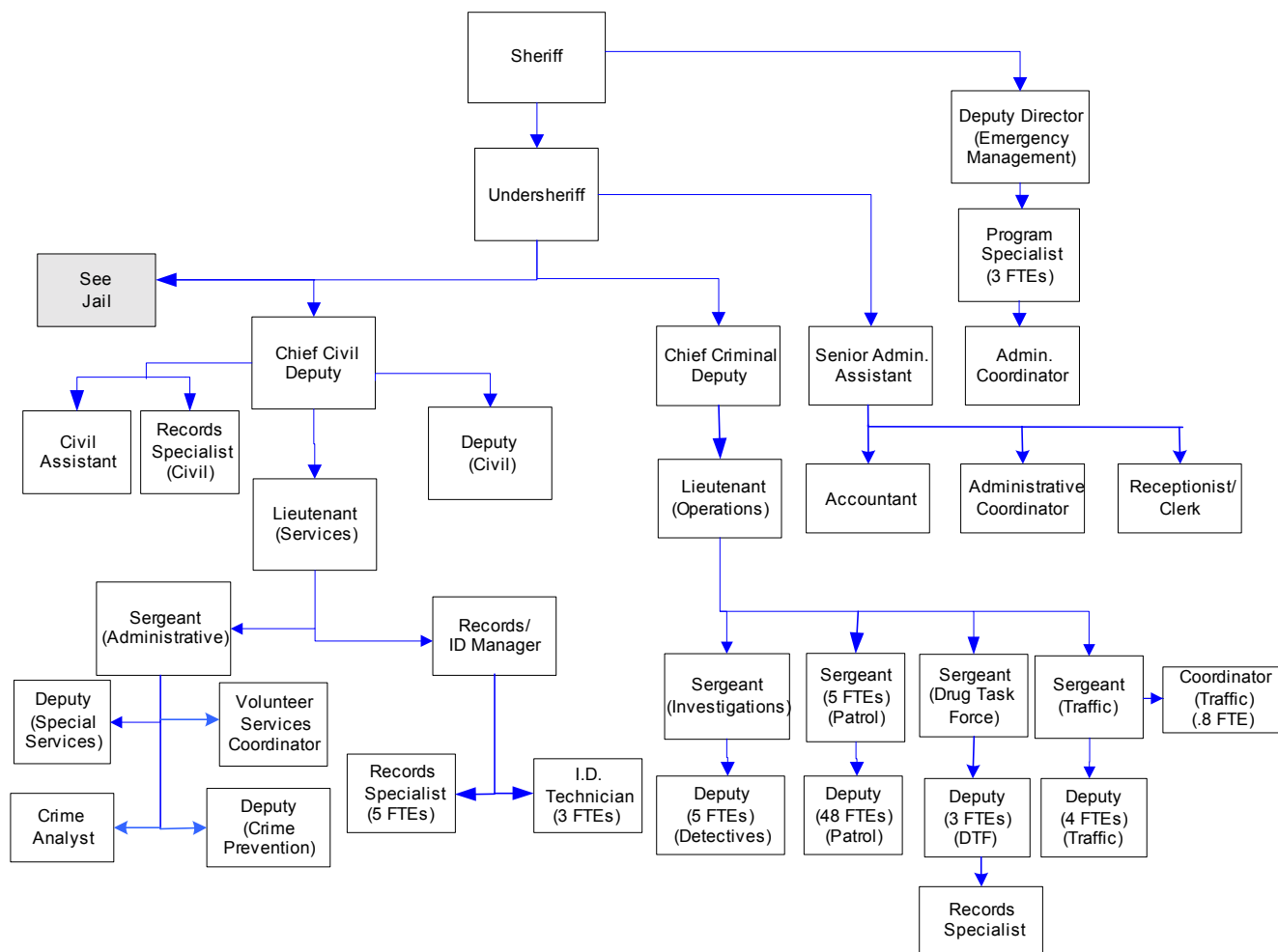

Mission & Objectives

Mission

Provide emergency response, law enforcement, and public safety services of the highest quality possible within financial, staffing, and operational limits, and consistently and continually strive to affirmatively promote, preserve, and enhance the peace, safety, and security of the citizens of Whatcom County.

Emergency Management

Develop and maintain a community infrastructure for emergency/disaster mitigation, planning, response and recovery, through public education, training, planning and team building.

Objectives

Patrol, Investigations, Support

- Continue to aggressively attack problems associated with the illicit manufacture and distribution of methamphetamine and hazards associated with clandestine laboratories and dump sites. This plan also involves the continued focus of the drug task force and the meth strike force towards eradicating illicit methamphetamine laboratories.
- Enhance administrative capabilities to keep pace with growing workload demand (grant management/achievement of 240 additional accreditation standards/employee misconduct investigations) and requirements and address low ratio of managers to staff through innovative means and/or interlocal agreement.
- Improve the Sheriff's Office to rapidly, effectively and safely respond to critical incidents and emergencies and homeland security alerts, respond to neighborhood and community problems, and increase deputy sheriff availability and visibility. This includes a continuation of programs initiated in 2003-2004 involving deputy sheriffs reporting directly to their assigned areas, the maintenance of off-site offices, the foothills resident deputy, the reserve deputy sheriff program and the use of technology to increase the time deputies are able to spend in their patrol areas. It also includes appropriately training and equipping deputies with non-lethal alternatives to deadly force.
- Explore enhancing response capabilities by partnering with other units of government (with Council/Executive approval) in mutually advantageous interlocal agreements for law enforcement services and other agreements that will expand the visibility and availability of deputies without significantly impacting costs.
- Enhance means to conduct follow-up criminal investigations. Due to resource limitations, only minimal follow up investigation is conducted on property crimes. Drastic improvements are needed to improve capabilities to follow up on child abuse/neglect complaints, which are increasing in both volume, severity and complexity.
- Expand Sheriff's Office capabilities through

Objectives continued

volunteer services. Continue on successes from 2004 to include providing field training to the new reserve deputies, pursue grants to equip reserves, recruit and select additional reserve deputies and other volunteers, work with Whatcom Community College to hold another reserve officer training academy and expand other volunteer programs in the Sheriff's Office. Coordinate the Explorer program. Improve retention of the 200+ skilled volunteers at Search and Rescue. The projected value of volunteer services at the Sheriff's Office in 2005 (excluding Search and Rescue and Explorers) is \$148,784 (using US DOL calculation valuing volunteer labor at \$16.54 per hour).

- Obtain necessary funding, equipment, infrastructure and technology in order to take advantage of technological advances in communications, information sharing, mobile reporting and data access. Pursue nontraditional funding sources to ensure continued effective delivery of services.
- Provide ongoing training to commissioned personnel in the areas of interviewing, major crimes investigations, and crime scene investigations.

Emergency Management

- Coordinate all jurisdictional counter-terrorism efforts and Department of Homeland Security activities.
- Implement local and state homeland security strategies.
- Effectively respond to multi-jurisdictional/multi-agency incidents.
- Implement and exercise the emergency plans of Emergency Management Council jurisdictions.
- Facilitate the activities of the Whatcom County Citizen Corps Council including the Community Emergency Response Team (CERT) program.

Expenditure Trends

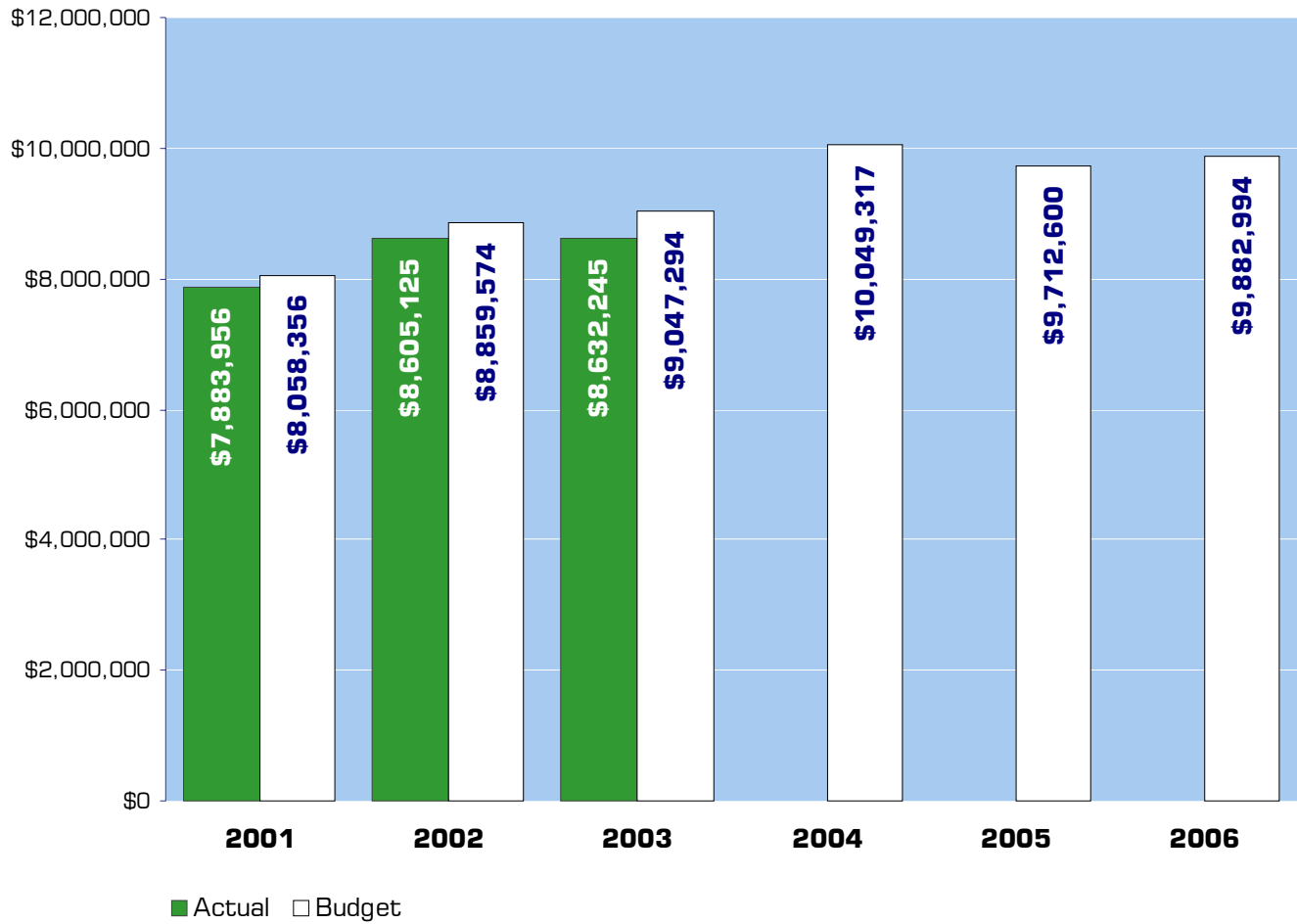

NOTE: Capital expenditures and interfund operating transfers are not shown to more accurately reflect ongoing operational costs.

2005-2006 Budget by Program

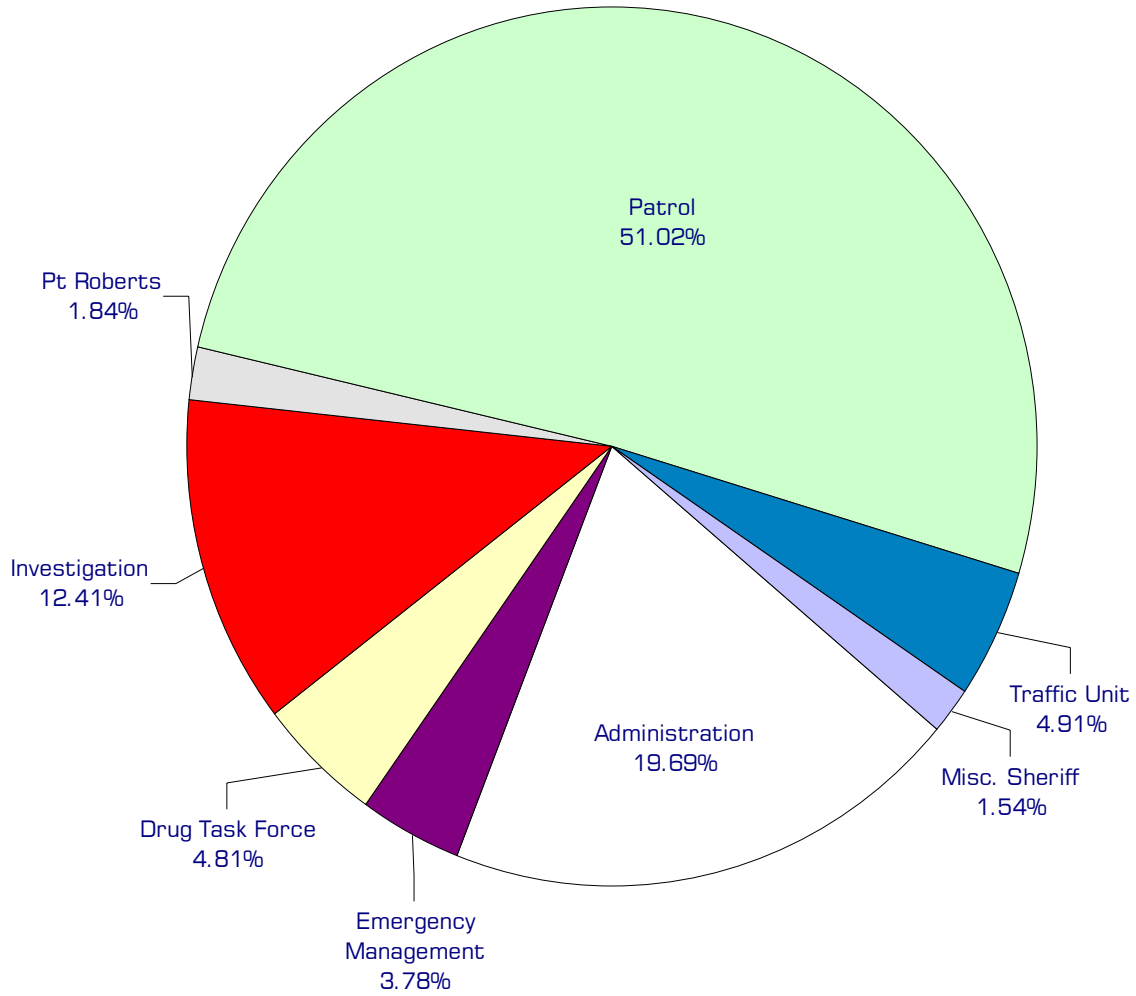

NOTE: Capital expenditures and interfund operating and residual equity transfers are not shown to more accurately reflect ongoing operational costs.

Program Summary

	Actual 2001	Actual 2002	Actual 2003	Budget 2004	Budget 2005	Budget 2006
OPERATIONS						
General Fund						
2900 Sheriff Administration	1,555,955	1,638,923	1,610,208	1,796,910	1,901,400	1,957,631
2910 Investigations	1,214,113	1,189,552	1,185,454	1,381,228	1,198,953	1,232,822
2915 Fire Marshall	-	-	3,707	-	7,448	6,000
2920 Patrol	4,316,045	4,591,565	4,736,261	5,509,222	4,836,485	4,925,933
2925 Off-Site Offices	-	-	45,878	25,350	20,651	20,651
2930 Traffic Unit	83,309	85,213	77,252	100,033	478,209	483,329
2932 Traffic Safety	-	-	15,585	45,754	18,520	-
2940 Training	29,481	49,719	45,391	58,339	61,605	56,305
2950 East Side Deputy	-	-	-	95,588	96,080	97,411
2960 Boating Safety Program	11,271	18,278	13,831	60,118	60,118	60,118
2965 Reimbursable Overtime	80,292	293,804	171,326	116,163	15,585	15,846
2970 Drug Task Force	146,414	150,797	180,418	171,375	466,376	475,381
2975 Peace Arch Rally	12,971	-	-	-	-	-
2980 Pt Roberts	146,797	144,591	151,203	158,007	179,157	182,173
2985 LLEB Grant	4,640	22,864	22,587	34,107	-	-
2990 Sheriff - HIDTA Grant	30,628	56,723	22,920	7,200	-	-
2995 Cops More Grant	460	31,755	-	-	-	-
Emergency Management						
16700 Emergency Management	243,346	327,997	347,986	356,433	307,283	298,634
16720 CERT Program	801	3,344	2,238	14,757	5,000	5,000
16735 Homeland Security Grant	-	-	-	118,733	13,119	-
16736 Homeland Sec Grnt-E05-071	-	-	-	-	46,611	65,760
16775 Peace Arch Rally	7,433	-	-	-	-	-
<i>Total Sheriff Operations</i>	7,883,956	8,605,125	8,632,245	10,049,317	9,712,600	9,882,994

continued on next page

Program Summary continued

	Actual 2001	Actual 2002	Actual 2003	Budget 2004	Budget 2005	Budget 2006
CAPITAL						
General Fund						
2900 Sheriff Administration	2,781	3,412	-	12,000	-	-
2910 Investigations	5,331	4,643	3,144	33,932	51,195	5,500
2920 Patrol	13,062	30,505	6,492	26,974	173,630	-
2925 Off-Site Offices	-	-	30,298	-	-	-
2932 Traffic Safety	-	-	-	4,275	-	-
2960 Boating Safety Program	-	1,666	8,736	-	-	-
2970 Drug Task Force	-	-	-	8,430	-	-
2985 LLEB Grant	-	34,801	19,204	-	-	-
2990 Sheriff - HIDTA Grant	21,251	56,650	10,582	-	-	-
2995 Cops More Grant	1,150	-	-	-	-	-
Emergency Management						
16700 Emergency Management	4,364	-	8,337	5,000	-	-
16735 Homeland Security Grant	-	-	-	329,512	-	-
16760 Citizen's Core	-	-	-	15,500	-	-
<i>Total Sheriff Capital</i>	47,939	131,677	86,793	435,623	224,825	5,500
TRANSFERS						
General Fund						
2900 Sheriff Administration	3,803	-	-	2,000	3,414	2,547
2910 Investigations	5,075	-	-	-	34,500	-
2920 Patrol	173,512	-	-	69,000	6,000	4,000
2930 Traffic Unit	342	-	-	-	22,800	-
2940 Training	-	10,877	11,998	11,259	13,095	13,095
2950 East Side Deputy	-	-	-	34,500	-	-
2970 Drug Task Force	349	-	-	-	-	-
2980 Pt Roberts	601	-	-	-	-	-
16700 Emergency Management	2,248	-	-	-	-	-
16735 Homeland Security Grant	-	-	-	38,627	-	-
<i>Total Sheriff Transfers</i>	185,930	10,877	11,998	155,386	79,809	19,642
TOTAL SHERIFF	8,117,825	8,747,679	8,731,036	10,640,326	10,017,234	9,908,136
<i>Percent Change from Previous Year</i>	13.5%	7.8%	-0.2%	21.9%	-5.9%	-1.1%

2005-2006 Funding Sources

	2005	2006
General Fund	8,028,640	8,211,149
Intergovernmental Revenues	344,750	326,777
Road Levy Diversion	706,530	706,530
Charges for Services	125,567	125,827
Emergency Services Support	147,549	144,286
Miscellaneous Revenues	122,165	122,165
Operating Transfer-Drug Fund	236,512	243,607
*Fund Balance	887	2,653
Total Funding	9,712,600	9,882,994

General Fund

Undedicated General Fund resources.

Intergovernmental Revenues

The Sheriff's Department receives federal and state grants for specific operations it performs. These operations include Narcotics Task Force, Homeland Security, Traffic Safety, and Forest Patrol.

Road Levy Diversion

A direct diversion of part of the Road Fund's property tax revenues is used to fund Sheriff's Department deputies for traffic related work.

Charges for Services

Fees charged for various activities such as fingerprinting, civil service, and reimbursable overtime.

Emergency Services Support

The incorporated cities of Whatcom County and the Port of Bellingham contribute revenue to partially fund the Sheriff's Emergency Management operations.

Miscellaneous Revenue

Includes vessel registration fees for the boating safety program and the department's share of timber taxes and sales as a result of receiving diverted road taxes.

Operating Transfer In from Drug Fund

To fund drug task force operations.

Fund Balance - Emergency Management Fund

Fund balance from the Emergency Management Fund will be used to support operations. \$887 will be used in 2005, and \$2,653 will be used in 2006.

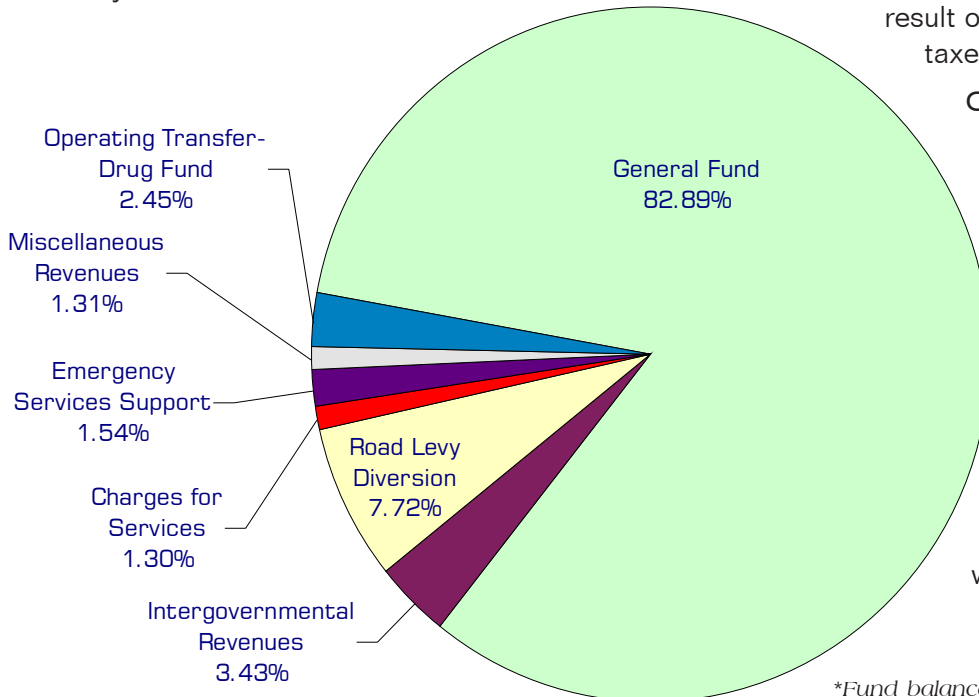

*Fund balance is not included in above chart.

Performance / Activity Measures

	Actual 2001	Actual 2002	Actual 2003	Projected 2004	Projected 2005	Projected 2006
<i>Administration</i>						
<i>Civil Department</i>						
Writs of Attachment - Real Property	2	2	2	2	-	-
Personal Property Sales	8	7	5	5	3	3
Subpoenas to deputies	5,412	6,555	6,700	6,850	6,400	6,600
Real property sales	13	16	26	30	20	24
Writs of Restitution (evictions)	222	264	317	360	375	400
Total Civil Papers Served/Mailed	8,307	9,409	9,500	9,725	8,649	8,984
Attorney papers served	1,877	1,936	2,000	2,075	1,825	1,925
Writs of Attachment - Personal Property	2	2	3	4	2	2
Writs of Replevin	8	3	6	6	4	5
Writs of Habeas Corpus	1	3	10	15	20	25
Fees Collected	\$ 43,221	\$ 43,500	\$ 42,500	\$ 44,000	\$ 56,000	\$ 64,000
Total Eviction Writs and Sales	256	297	300	350	424	459
Subpoenas mailed	1,018	918	800	800	-	-
<i>Records and Identification Bureau</i>						
Fingerprints (applicants and Jail)	5,709	5,756	5,700	5,758	5,753	5,763
Concealed Pistol licenses	924	935	900	950	938	942
Firearm Purchases	995	747	825	900	815	891
Sex Offender Registrations	289	318	300	325	330	348
Citations Issued	8,144	10,185	10,100	11,000	11,978	12,827
Records Checks	980	1,255	1,250	1,300	1,435	1,458
Warrants Received	3,218	2,303	2,300	2,400	2,431	2,480
Warrants Served	1,532	956	1,100	1,200	1,329	1,451
Domestic Orders Received	1,145	1,042	1,125	1,200	1,190	1,269
Domestic Orders Served	365	283	280	300	305	314
<i>Emergency Management</i>						
Logged incidents	126	89	101	100	100	100
Weather bulletins issued	11	20	18	25	25	25
On-scene responses and/or EOC activations	21	18	33	25	25	25
Conduct/participate in Exercises		12	12	12	12	15
<i>Operations</i>						
<i>Investigations and Patrol</i>						
Stolen Property	\$ 2,510,346	\$ 2,768,961	\$ 2,400,000	\$ 2,500,000	\$ 2,500,000	\$ 2,600,000
Total Part Two Crimes	4,637	5,014	5,100	5,200	5,350	5,500
Total Part One Crimes	2,004	2,181	2,450	2,300	2,450	2,500
Recovered Stolen Property	\$ 707,351	\$ 802,299	\$ 780,000	\$ 800,000	\$ 800,000	\$ 810,000
Calls for Service	24,648	26,930	28,815	31,000	30,100	31,400

Expenditures Summary

	Actual 2001	Actual 2002	Actual 2003	Budget 2004	Budget 2005	Budget 2006
GENERAL FUND						
2900 Administration						
Salaries & Wages	600,152	610,513	639,589	753,437	727,817	746,100
Benefits	229,169	249,161	156,215	199,384	231,791	252,738
Supplies	96,524	99,963	99,531	87,128	94,547	94,547
Other Services & Charges	630,110	679,286	714,873	756,961	847,245	864,246
Capital Outlay	2,781	3,412	-	12,000	-	-
Operating Transfers	3,803	-	-	2,000	3,414	2,547
<i>Total Administration</i>	<i>1,562,539</i>	<i>1,642,335</i>	<i>1,610,208</i>	<i>1,810,910</i>	<i>1,904,814</i>	<i>1,960,178</i>
<i>Percent Change from Previous Year</i>	<i>5.8%</i>	<i>5.1%</i>	<i>-2.0%</i>	<i>12.5%</i>	<i>5.2%</i>	<i>2.9%</i>
2910 Investigations						
Salaries & Wages	865,545	881,869	878,039	1,004,661	816,405	835,893
Benefits	262,346	233,459	243,655	285,378	265,759	290,230
Supplies	1,786	4,135	1,870	-	8,954	-
Other Services & Charges	84,436	70,089	61,890	91,189	107,835	106,699
Capital Outlay	5,331	4,643	3,144	33,932	51,195	5,500
Operating Transfers	5,075	-	-	-	-	-
Residual Equity Transfers	-	-	-	-	34,500	-
<i>Total Investigations</i>	<i>1,224,519</i>	<i>1,194,195</i>	<i>1,188,598</i>	<i>1,415,160</i>	<i>1,284,648</i>	<i>1,238,322</i>
<i>Percent Change from Previous Year</i>	<i>17.2%</i>	<i>-2.5%</i>	<i>-0.5%</i>	<i>19.1%</i>	<i>-9.2%</i>	<i>-3.6%</i>
2915 Fire Marshall						
Salaries & Wages	-	-	3,026	-	6,000	6,000
Supplies	-	-	681	-	1,448	-
<i>Total Fire Marshall</i>	<i>-</i>	<i>-</i>	<i>3,707</i>	<i>-</i>	<i>7,448</i>	<i>6,000</i>
<i>Percent Change from Previous Year</i>	<i>-100.0%</i>	<i>0.0%</i>	<i>0.0%</i>	<i>-100.0%</i>	<i>0.0%</i>	<i>0.0%</i>
2920 Patrol						
Salaries & Wages	2,917,515	3,061,861	3,028,677	3,609,545	3,078,124	3,124,655
Benefits	776,746	774,863	869,669	1,066,881	1,033,286	1,103,383
Supplies	8,542	23,854	80,674	90,437	65,955	41,775
Other Services & Charges	613,242	730,987	757,241	742,359	659,120	656,120
Capital Outlay	13,062	30,505	6,492	26,974	173,630	-
Operating Transfers	26,166	-	-	-	-	-
Residual Equity Transfers	147,346	-	-	69,000	6,000	4,000
<i>Total Patrol</i>	<i>4,502,619</i>	<i>4,622,070</i>	<i>4,742,753</i>	<i>5,605,196</i>	<i>5,016,115</i>	<i>4,929,933</i>
<i>Percent Change from Previous Year</i>	<i>21.7%</i>	<i>2.7%</i>	<i>2.6%</i>	<i>18.2%</i>	<i>-10.5%</i>	<i>-1.7%</i>
2925 Off-Site Offices						
Supplies	-	-	37,510	7,050	-	-
Other Services & Charges	-	-	8,368	18,300	20,651	20,651
Capital Outlay	-	-	30,298	-	-	-
<i>Total Special Units</i>	<i>-</i>	<i>-</i>	<i>76,176</i>	<i>25,350</i>	<i>20,651</i>	<i>20,651</i>
<i>Percent Change from Previous Year</i>	<i>0.0%</i>	<i>0.0%</i>	<i>0.0%</i>	<i>-66.7%</i>	<i>-18.5%</i>	<i>0.0%</i>

continued on next page

Expenditures Summary continued

	Actual 2001	Actual 2002	Actual 2003	Budget 2004	Budget 2005	Budget 2006
2930 Traffic						
Salaries & Wages	57,727	60,311	60,379	69,859	300,041	301,444
Benefits	16,582	15,662	16,873	19,374	97,742	104,606
Supplies	-	-	-	-	3,147	-
Other Services & Charges	9,000	9,240	-	10,800	77,279	77,279
Operating Transfers	342	-	-	-	-	-
Residual Equity Transfers	-	-	-	-	22,800	-
Total Traffic	83,651	85,213	77,252	100,033	501,009	483,329
<i>Percent Change from Previous Year</i>	13.7%	1.9%	-9.3%	29.5%	400.8%	-3.5%
2932 Traffic Safety						
Salaries & Wages	-	-	9,563	28,271	12,528	-
Benefits	-	-	860	10,628	5,992	-
Supplies	-	-	4,115	6,255	-	-
Other Services & Charges	-	-	1,047	600	-	-
Capital Outlay	-	-	-	4,275	-	-
Total Traffic Safety	-	-	15,585	50,029	18,520	-
<i>Percent Change from Previous Year</i>	0.0%	0.0%	0.0%	221.0%	-63.0%	-100.0%
2940 Training						
Supplies	-	10,545	5,179	18,364	12,500	12,500
Other Services & Charges	29,481	39,174	40,212	39,975	49,105	43,805
Operating Transfers	-	10,877	11,998	11,259	13,095	13,095
Total Training	29,481	60,596	57,389	69,598	74,700	69,400
<i>Percent Change from Previous Year</i>	-8.9%	105.5%	-5.3%	21.3%	7.3%	-7.1%
2950 East Side Deputy						
Salaries & Wages	-	-	-	52,374	54,077	54,251
Benefits	-	-	-	16,184	18,873	20,030
Supplies	-	-	-	3,500	-	-
Other Services & Charges	-	-	-	23,530	23,130	23,130
Residual Equity Transfers	-	-	-	34,500	-	-
Total East Side Deputy	-	-	-	130,088	96,080	97,411
<i>Percent Change from Previous Year</i>	0.0%	0.0%	0.0%	0.0%	-26.1%	1.4%
2960 Boating Safety Program						
Supplies	8,542	7,630	8,432	26,118	26,118	26,118
Other Services & Charges	2,729	10,648	5,399	34,000	34,000	34,000
Capital Outlay	-	1,666	8,736	-	-	-
Total Boating Safety Prog.	11,271	19,944	22,567	60,118	60,118	60,118
<i>Percent Change from Previous Year</i>	-33.5%	76.9%	13.2%	166.4%	0.0%	0.0%
2965 Reimbursable Overtime						
Salaries & Wages	65,983	240,413	138,103	101,460	13,775	13,775
Benefits	14,309	53,391	33,223	14,703	1,810	2,071
Total Reimbursable Overtime	80,292	293,804	171,326	116,163	15,585	15,846
<i>Percent Change from Previous Year</i>	0.0%	265.9%	-41.7%	-32.2%	-86.6%	1.7%

continued on next page

Expenditures Summary continued

	Actual 2001	Actual 2002	Actual 2003	Budget 2004	Budget 2005	Budget 2006
2970 Drug Task Force						
Salaries & Wages	61,445	61,725	71,828	69,290	279,023	281,276
Benefits	17,670	15,841	21,337	19,277	91,903	98,655
Supplies	417	3,088	4,044	2,168	2,168	2,168
Other Services & Charges	66,882	70,143	83,209	80,640	93,282	93,282
Capital Outlay	-	-	-	8,430	-	-
Operating Transfers	349	-	-	-	-	-
<i>Total Drug Task Force</i>	<i>146,763</i>	<i>150,797</i>	<i>180,418</i>	<i>179,805</i>	<i>466,376</i>	<i>475,381</i>
<i>Percent Change from Previous Year</i>	<i>25.0%</i>	<i>2.7%</i>	<i>19.6%</i>	<i>-0.3%</i>	<i>159.4%</i>	<i>1.9%</i>
2975 Peace Arch Rally						
Salaries & Wages	11,441	-	-	-	-	-
Benefits	1,530	-	-	-	-	-
<i>Total Peace Arch Rally</i>	<i>12,971</i>	<i>-</i>	<i>-</i>	<i>-</i>	<i>-</i>	<i>-</i>
<i>Percent Change from Previous Year</i>	<i>-89.2%</i>	<i>-100.0%</i>	<i>0.0%</i>	<i>0.0%</i>	<i>0.0%</i>	<i>0.0%</i>
2980 Pt Roberts						
Salaries & Wages	112,851	114,245	118,689	120,260	116,495	117,061
Benefits	33,946	30,346	32,514	36,547	38,933	41,383
Other Services & Charges	-	-	-	1,200	23,729	23,729
Operating Transfers	601	-	-	-	-	-
<i>Total Pt Roberts</i>	<i>147,398</i>	<i>144,591</i>	<i>151,203</i>	<i>158,007</i>	<i>179,157</i>	<i>182,173</i>
<i>Percent Change from Previous Year</i>	<i>23.2%</i>	<i>-1.9%</i>	<i>4.6%</i>	<i>4.5%</i>	<i>13.4%</i>	<i>1.7%</i>
2985 LLEB Grant						
Supplies	4,640	22,864	12,849	34,107	-	-
Other Services & Charges	-	-	9,738	-	-	-
Capital Outlay	-	34,801	19,204	-	-	-
<i>Total LLEB Grant</i>	<i>4,640</i>	<i>57,665</i>	<i>41,791</i>	<i>34,107</i>	<i>-</i>	<i>-</i>
<i>Percent Change from Previous Year</i>	<i>0.0%</i>	<i>1142.8%</i>	<i>-27.5%</i>	<i>-18.4%</i>	<i>-100.0%</i>	<i>0.0%</i>
2990 Sheriff - HIDTA Grant						
Supplies	1,639	26,161	6,871	-	-	-
Other Services & Charges	28,989	30,562	16,049	7,200	-	-
Capital Outlay	21,251	56,650	10,582	-	-	-
<i>Total Sheriff - HIDTA Grant</i>	<i>51,879</i>	<i>113,373</i>	<i>33,502</i>	<i>7,200</i>	<i>-</i>	<i>-</i>
<i>Percent Change from Previous Year</i>	<i>-70.4%</i>	<i>118.5%</i>	<i>-70.4%</i>	<i>-78.5%</i>	<i>-100.0%</i>	<i>0.0%</i>
2995 Cops More Grant						
Salaries & Wages	-	22,166	-	-	-	-
Benefits	-	6,062	-	-	-	-
Supplies	460	2,119	-	-	-	-
Other Services & Charges	-	1,408	-	-	-	-
Capital Outlay	1,150	-	-	-	-	-
<i>Total Cops More Grant</i>	<i>1,610</i>	<i>31,755</i>	<i>-</i>	<i>-</i>	<i>-</i>	<i>-</i>
<i>Percent Change from Previous Year</i>	<i>0.0%</i>	<i>1872.4%</i>	<i>-100.0%</i>	<i>0.0%</i>	<i>0.0%</i>	<i>0.0%</i>
<i>Total General Fund</i>	<i>7,859,633</i>	<i>8,416,338</i>	<i>8,372,475</i>	<i>9,761,764</i>	<i>9,645,221</i>	<i>9,538,742</i>
<i>Percent Change from Previous Year</i>	<i>14.3%</i>	<i>7.1%</i>	<i>-0.5%</i>	<i>16.6%</i>	<i>-1.2%</i>	<i>-1.1%</i>

continued on next page

Expenditures Summary continued

	Actual 2001	Actual 2002	Actual 2003	Budget 2004	Budget 2005	Budget 2006
2995 Cops More Grant						
Salaries & Wages	-	22,166	-	-	-	-
Benefits	-	6,062	-	-	-	-
Supplies	460	2,119	-	-	-	-
Other Services & Charges	-	1,408	-	-	-	-
Capital Outlay	1,150	-	-	-	-	-
<i>Total Cops More Grant</i>	1,610	31,755	-	-	-	-
<i>Percent Change from Previous Year</i>	0.0%	1872.4%	-100.0%	0.0%	0.0%	0.0%
<i>Total General Fund</i>	7,859,633	8,416,338	8,372,475	9,761,764	9,645,221	9,538,742
<i>Percent Change from Previous Year</i>	14.3%	7.1%	-0.5%	16.6%	-1.2%	-1.1%
167 EMERGENCY MANAGEMENT FUND						
16700 Emergency Management						
Salaries & Wages	136,909	172,583	179,200	187,429	158,227	148,994
Benefits	41,909	44,653	49,361	53,719	49,293	50,772
Supplies	6,499	6,418	8,637	9,064	7,440	7,440
Other Services & Charges	58,029	104,343	110,788	106,221	92,323	91,428
Capital Outlay	4,364	-	8,337	5,000	-	-
Operating Transfers	2,248	-	-	-	-	-
<i>Total Emergency Mgmt</i>	249,958	327,997	356,323	361,433	307,283	298,634
<i>Percent Change from Previous Year</i>	-9.6%	31.2%	8.6%	1.4%	-15.0%	-2.8%
16720 CERT Program						
Supplies	801	3,344	1,988	11,372	5,000	5,000
Other Services & Charges	-	-	250	3,385	-	-
<i>Total CERT Program</i>	801	3,344	2,238	14,757	5,000	5,000
<i>Percent Change from Previous Year</i>	0	317.5%	-33.1%	559.4%	-66.1%	0.0%
16735 Homeland Security Grant						
Salaries & Wages	-	-	-	37,872	9,719	-
Benefits	-	-	-	12,084	3,400	-
Other Services & Charges	-	-	-	68,777	-	-
Capital Outlay	-	-	-	329,512	-	-
Operating Transfer	-	-	-	38,627	-	-
<i>Total Homeland Security Grant</i>	-	-	-	486,872	13,119	-
<i>Percent Change from Previous Year</i>	0.0%	0.0%	0.0%	0.0%	-97.3%	-100.0%
16736 Homeland Security Grt-E05-071						
Salaries & Wages	-	-	-	-	34,146	47,561
Benefits	-	-	-	-	11,465	17,199
Other Services & Charges	-	-	-	-	1,000	1,000
<i>Total Homeland Security Grt-E05-0,</i>	-	-	-	-	46,611	65,760
<i>Percent Change from Previous Year</i>	0.0%	0.0%	0.0%	0.0%	0.0%	41.1%
16760 Citizen Corps						
Benefits	-	-	-	1,300	-	-
Supplies	-	-	-	1,000	-	-
Other Services & Charges	-	-	-	13,200	-	-
<i>Total Citizen Corps</i>	-	-	-	15,500	-	-
<i>Percent Change from Previous Year</i>	0.0%	0.0%	0.0%	0.0%	-100.0%	0.0%

continued on next page

Expenditures Summary continued

	Actual 2001	Actual 2002	Actual 2003	Budget 2004	Budget 2005	Budget 2006
16775 Peace Arch Rally						
Salaries & Wages	101	-	-	-	-	-
Benefits	13	-	-	-	-	-
Supplies	4,544	-	-	-	-	-
Other Services & Charges	2,775	-	-	-	-	-
<i>Total Peace Arch Rally</i>	<i>7,433</i>	<i>-</i>	<i>-</i>	<i>-</i>	<i>-</i>	<i>-</i>
<i>Percent Change from Previous Year</i>	<i>0.0%</i>	<i>-100.0%</i>	<i>0.0%</i>	<i>0.0%</i>	<i>0.0%</i>	<i>0.0%</i>
<i>Total Emergency Management</i>	<i>258,192</i>	<i>331,341</i>	<i>358,561</i>	<i>878,562</i>	<i>372,013</i>	<i>369,394</i>
<i>Percent Change from Previous Year</i>	<i>-6.7%</i>	<i>28.3%</i>	<i>8.2%</i>	<i>145.0%</i>	<i>-57.7%</i>	<i>-0.7%</i>
TOTAL SHERIFF	8,117,825	8,747,679	8,731,036	10,640,326	10,017,234	9,908,136
<i>Percent Change from Previous Year</i>	<i>13.5%</i>	<i>7.8%</i>	<i>-0.2%</i>	<i>21.9%</i>	<i>-5.9%</i>	<i>-1.1%</i>

Services

Administration

Sheriff - Civil Division

Provides intake, processing and service of civil process.

Records Bureau and Identification

The records and identification bureaus perform record keeping, data entry, fingerprinting, criminal files, submissions, permits and licenses, report retention and information management for the Sheriff's Office as mandated by law.

Emergency Management

Alert & Warning

This service involves the issuance of warnings to selected geographic areas. These warnings may include weather, flood, hazardous materials or evacuation instructions.

Chemical Inventory

Maintenance of the chemical inventory in Whatcom County, 10 billion pounds of hazardous materials at 100 facilities. The DEM provides this information to the public on request.

Communication Project

The Whatcom Emergency Radio System (WERS) is contracting a Program Manager to facilitate the development of a new emergency responder communications system.

Community Emergency Response Team (CERT)

CERT provides emergency preparedness and response information to citizens enabling them to take care of themselves and their family in the event that aid is not able to reach them in a timely manner following a disaster.

DEM Administration

Administrative management and planning of all day-to-day and long term operations of the DEM.

Disaster & Emergency Exercises

Exercises familiarize responders, assess plans or test specific functions. They are a key element in building response teams and developing coordinated emergency plans.

Disaster Planning

This service applies the four functions (planning, response, recovery and mitigation) of Emergency Management to the hazard vulnerabilities threatening Whatcom County.

Disaster/ Emergency Recovery

This service is incident specific; involving damage assessment, recovery efforts, promulgation of emergency proclamations, initiating requests assistance and coordination of assistance.

Services continued

Disaster/Emergency Response

The DEM serves as the coordination and resource agency for large emergencies or disasters, and may activate the EOC or respond to an incident. The EOC gathers and disseminates information and allocates resources.

Emergency Management Database

The DEM maintains critical emergency resource databases on: volunteers, facilities, materials and equipment. The DEM also maintains typical business databases, with fail-safe redundancies.

Hazard Identification & Vulnerability Analysis

A Hazard Identification and Vulnerability Analysis (HIVA) is a prelude to emergency management planning and it involves identifying the risks and their impact.

Hazardous Materials Planning

Develops hazardous materials response plans and Standard Operating Procedures for Whatcom County. Facilitates the LEPC and provides the mechanism to achieve the Community Right-to-Know of SARA Title III.

Homeland Security

To ensure that adequate planning, training and response capability is available to meet the threat of terrorism in Whatcom County.

Mitigation Planning

The development of a comprehensive strategy for eliminating or reducing the impact of jurisdictional natural hazards.

Public Education

Public education is provided on various hazards in Whatcom County and preparedness to reduce risks.

Responder Training

The DEM acts as a clearing house for a variety of responder training opportunities. The DEM conducts training when it is needed due to a change in procedures, personnel, or equipment.

Operations

Investigations Division

Handles the vast majority of major case investigations that require numerous hours of follow-up contacts and documentation prior to criminal charging or criminal trials.

Sheriff - Patrol

Provides Whatcom County law enforcement response to calls via personal contact, telephone or dispatch from 911 center.

County Sheriff - Jail

The Whatcom County Sheriff’s Office (WCSO) Corrections Division operates the Whatcom County Jail and the Alternative Corrections program. The jail is a medium security facility responsible for the incarceration of approximately 240 prisoners daily. The Corrections Division also oversees part of a statewide transport chain that links the various jails and detention facilities. A jail transport officer makes daily trips to Skagit, Snohomish, and King County Jails. The Corrections Division is also responsible for facilitating alternative sentencing programs. Currently the jail implements programs such as home detention and work release as alternatives to incarceration.

FTE’s for this department

Year	2001	2002	2003	*2004	*2005	*2006	<i>*budget</i>
FTE	60.00	60.00	60.00	63.00	65.00	65.00	

The chart here shows the organizational structure for 2005 only.

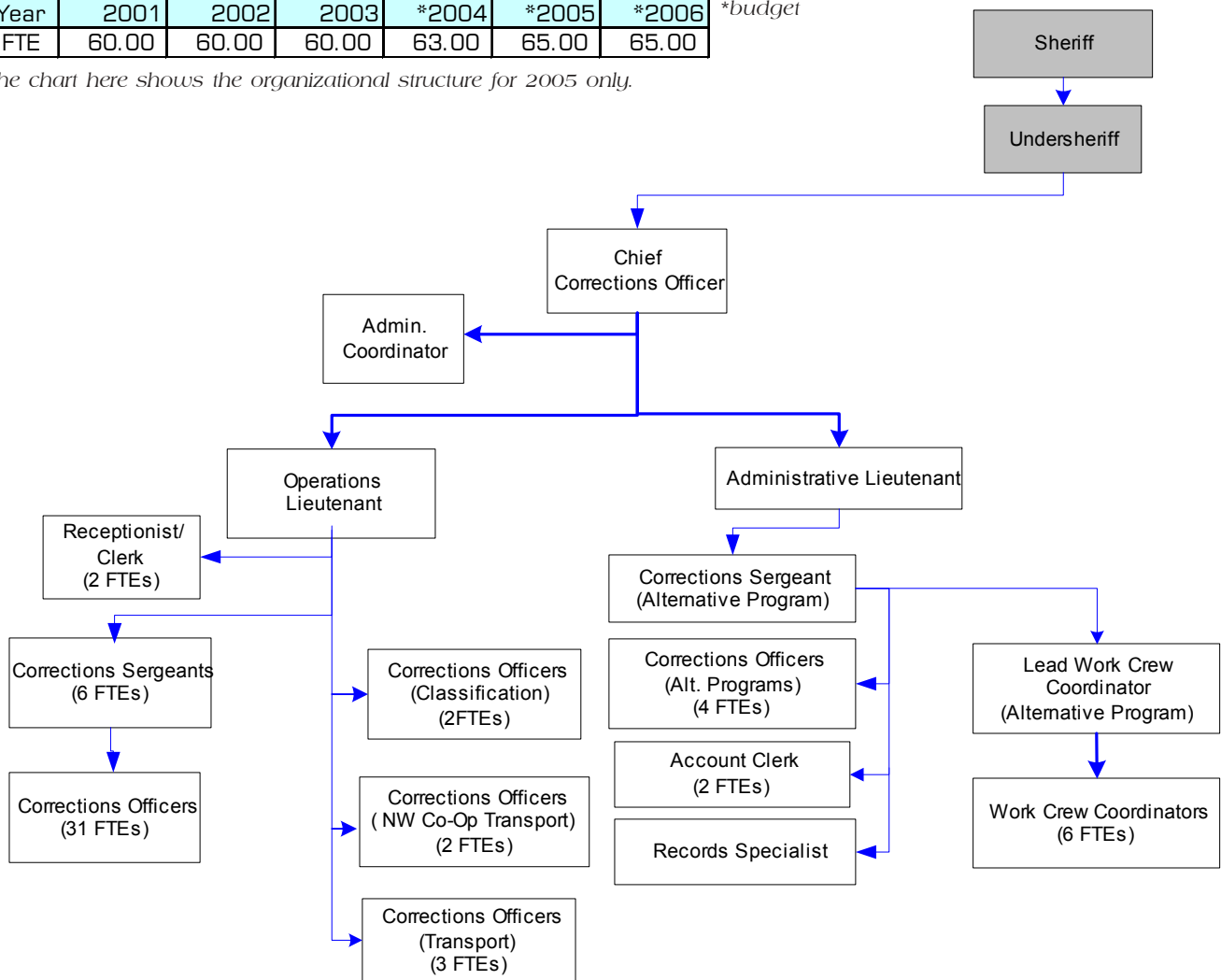

Mission & Objectives

Mission

Provide for the detention of all adults legally remanded into custody by the court or law enforcement agencies. To operate the jail according to best correctional practices, we will:

- Place offenders in the least restrictive environment allowed by their objective classification status, while ensuring the safety of the community.
- Whenever possible, provide offenders with the opportunity to positively change their behavior through the use of educational, vocational, and rehabilitative programs, and utilize the full range of correctional options to assist in this process.
- Operate all correctional facilities in a safe and secure manner, fulfilling all legal and moral imperatives.
- Provide a healthy environment for the offenders, the staff, and other members of the community.
- Manage the jail and any other corrections facility in a fiscally responsible manner.
- Facilitate continued professional development of the corrections staff through meaningful training opportunities and experiences.
- Hold corrections staff to the highest standards of professional conduct as promulgated in the department rules, regulations, and policies.
- Decrease the error rate in the computerized billing system from approximately 60 errors a month to 20 errors a month through enhancements to the current system, and implementation of an additional quality assurance process step.
- Fully implement the classification housing plan, including the institution of a tiered system of privileges, based on classification.
- Increase public access to jail information by expanding the Jail web site to include statistical information, victim notification information, and offender release dates.
- Increase law enforcement access to the inmate photo database by transferring the photo system to the AS/400.
- Control the growing average length of stay in the jail by improving the current Jail Population Management system to identify offenders remaining in-custody over 30 days, and initiating a review of the offender's status.
- Increase the average number of work crew on-site visits by uniformed staff from 1 per month to one per week .
- Increase community service projects performed by inmate work crews from an average of one per month to three per month.
- Increase the number of minor offenders diverted from the main jail by increasing the number of One Day Offender programs to 10 in 2005 and to 11 in 2006.
- Create a more formal offender grievance system that includes the ability to track and identify trends in complaints, and create the documentation needed to record both the original complaint and the jail staff's response.

Objectives

- Create transition plan for new Jail Annex, including logistics, timelines, scheduling, and local neighborhood involvement.

Expenditure Trends

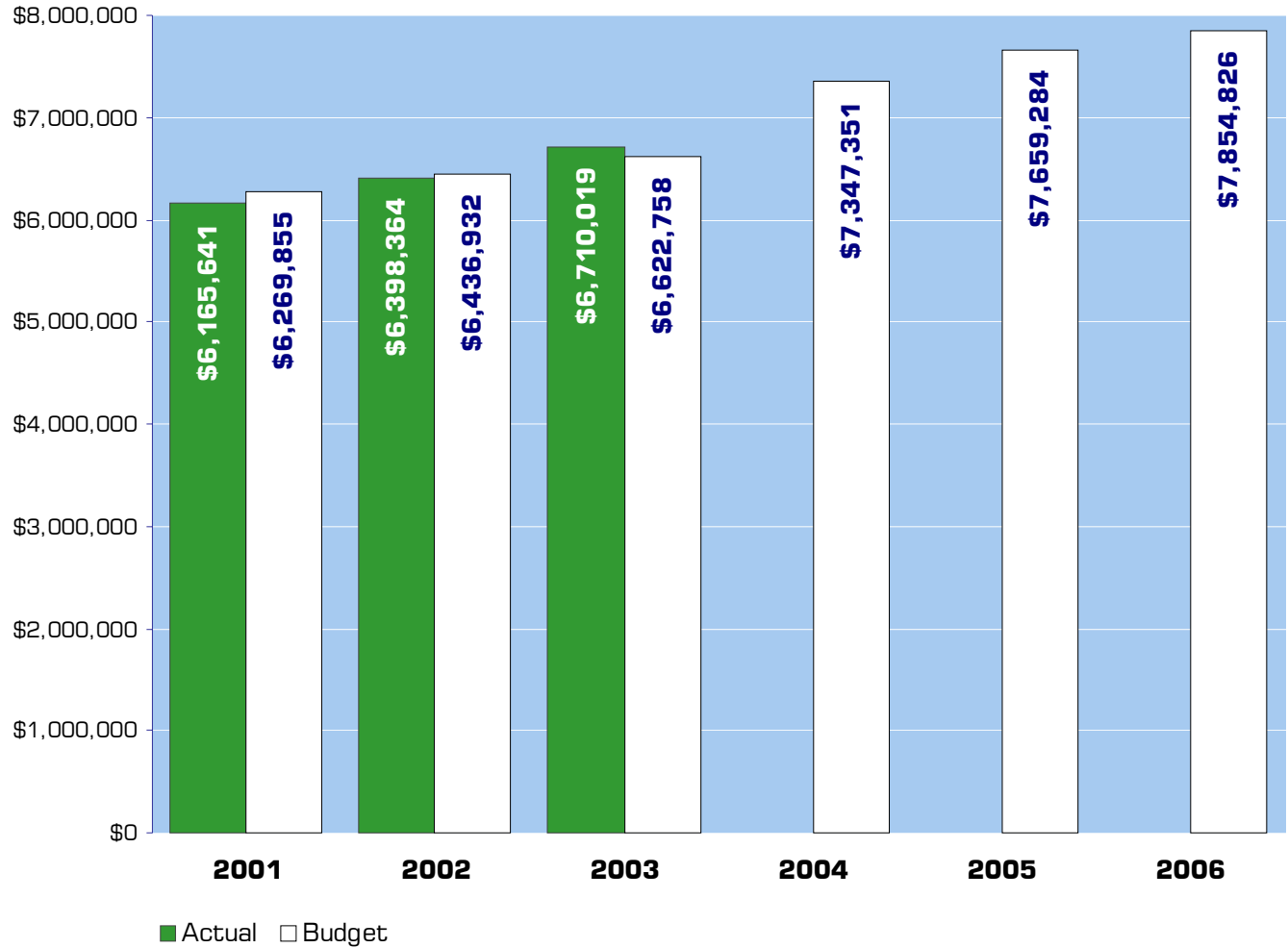

NOTE: Capital expenditures and interfund operating transfers are not shown to more accurately reflect ongoing operational costs.

2005-2006 Budget by Program

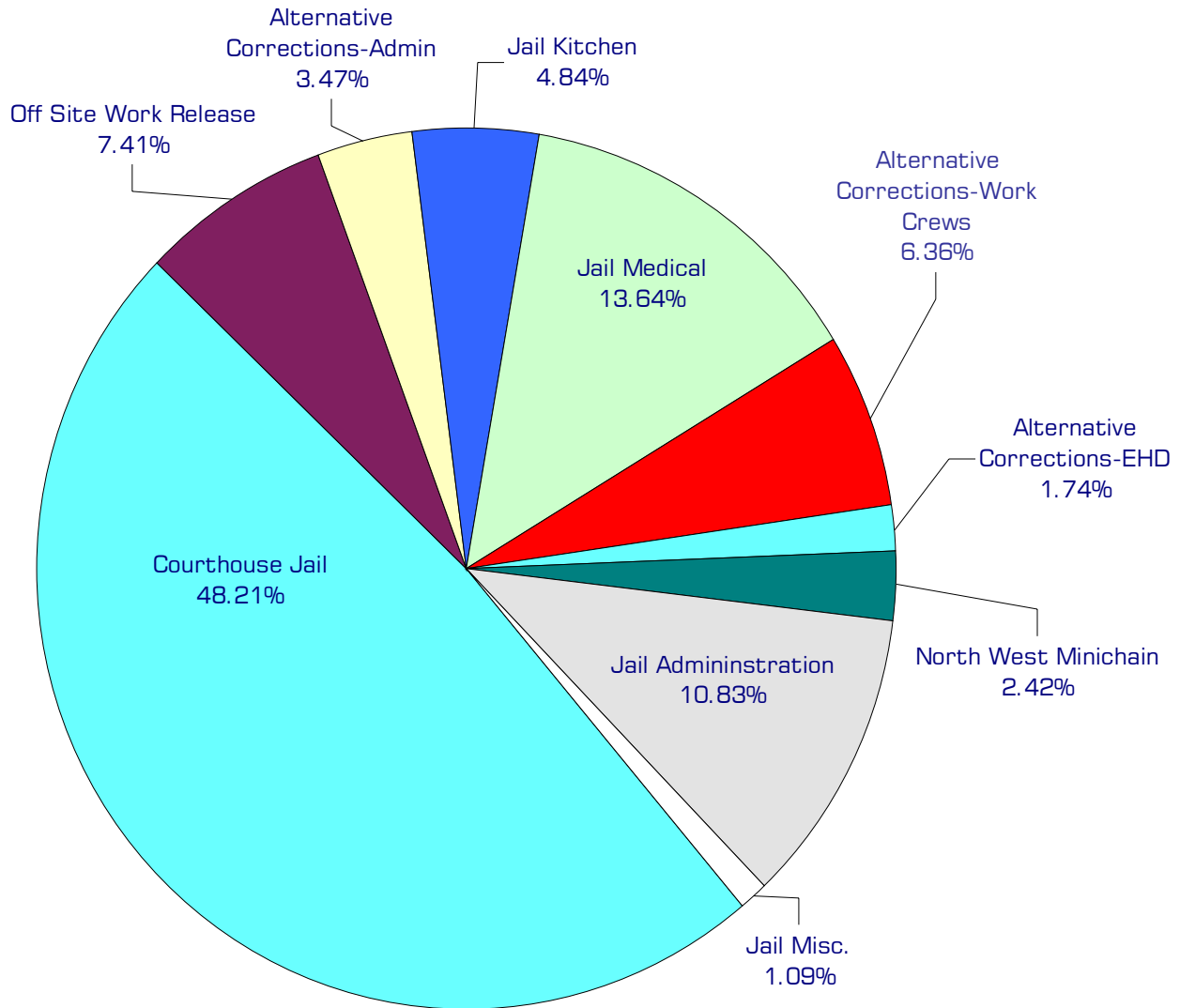

NOTE: Capital expenditures and interfund operating and residual equity transfers are not shown to more accurately reflect ongoing operational costs.

Program Summary

	Actual 2001	Actual 2002	Actual 2003	Budget 2004	Budget 2005	Budget 2006
OPERATIONS						
General Fund						
1800 Courthouse Jail	3,836,193	3,914,954	3,966,961	3,487,052	3,695,180	3,783,564
1810 Pt Roberts Jail	23,917	28,527	30,055	26,657	-	-
1815 Jail Administration	-	-	-	737,189	822,857	856,943
1820 Off Site Work Release	406,448	444,567	478,653	564,356	574,348	575,401
1840 Alt. Corrections - Admin	762,721	828,241	487,249	294,548	267,402	271,264
1842 Alt. Corrections Work Crews	-	-	331,371	387,304	481,857	504,580
1843 Forest Service Work Crew	-	-	44,135	81,898	76,877	77,666
1845 Alternative Correction - EHD	-	-	56,782	146,584	131,007	138,435
1847 One Day Offender	-	-	-	8,000	6,975	6,975
1850 Jail Kitchen	400,472	441,191	445,290	419,259	369,022	381,821
1860 Jail Medical	696,932	740,875	869,523	1,037,970	1,048,624	1,067,592
1870 Jail Commissary	31,642	-	-	-	-	-
1875 Peace Arch Rally	7,316	-	-	-	-	-
1880 North West Minichain	-	9	-	156,534	185,135	190,585
Total Jail Operations	6,165,641	6,398,364	6,710,019	7,347,351	7,659,284	7,854,826
CAPITAL						
General Fund						
1800 Courthouse Jail	1,266	-	185,452	53,130	43,340	48,000
1840 Alternative Corrections	6,105	-	-	-	-	-
1842 Alt. Corrections Work Crews	-	-	2,164	-	-	-
1843 Forest Service Work Crew	-	-	16,093	5,737	11,300	-
1850 Jail Kitchen	10,724	-	16,451	43,000	6,500	2,000
1860 Jail Medical	-	5,687	-	-	-	-
Total Jail Capital	18,095	5,687	220,160	101,867	61,140	50,000
TRANSFERS						
General Fund						
1800 Courthouse Jail	65,149	444,093	1,600	4,815	75,815	19,815
1840 Alternative Corrections	5,057	-	-	-	-	-
1850 Jail Kitchen	1,501	-	-	-	-	-
1860 Jail Medical	42,343	42,000	42,000	42,000	42,000	42,000
1870 Jail Commissary	384	-	-	-	-	-
Total Jail Transfers	114,434	486,093	43,600	46,815	117,815	61,815
TOTAL JAIL	6,298,170	6,890,144	6,973,779	7,496,033	7,838,239	7,966,641
Percent Change from Previous Year	9.9%	9.4%	1.2%	7.5%	4.6%	1.6%

2005-2006 Funding Sources

	2005	2006
Intergovernmental Revenues	1,617,380	1,563,197
Work Release & ICWC Fees	273,929	282,147
Electronic Home Monitor	201,009	207,129
Other Charges for Service	225,100	231,856
General Fund	4,981,185	5,199,757
Op Transfer In-Public Works	198,528	204,770
Op Transfer In-Admin Services	30,000	30,000
Contributions	5,000	5,000
Miscellaneous Revenues	127,153	130,970
Total Funding	7,659,284	7,854,826

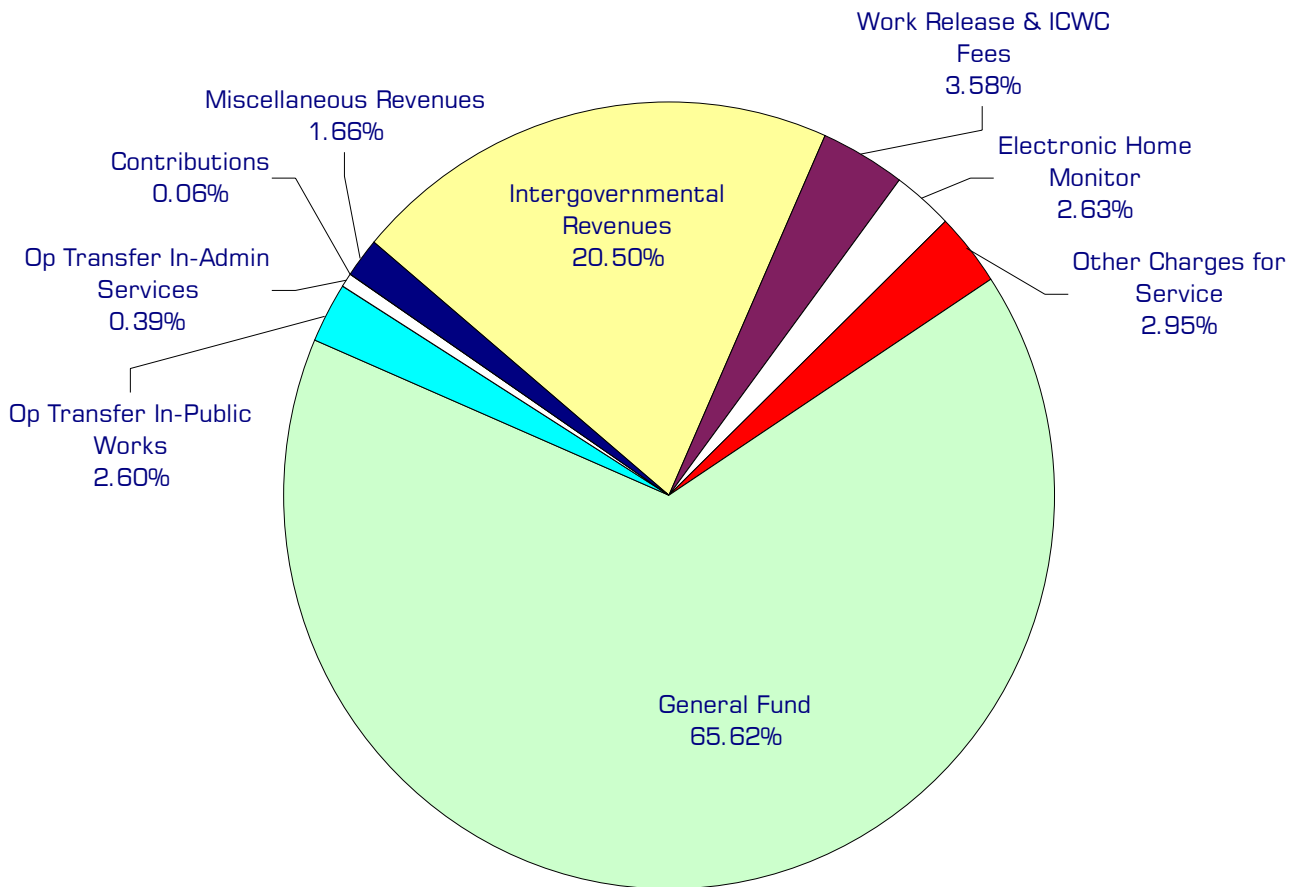

Funding Sources continued

Intergovernmental Revenues

The jail receives a per diem for housing other jurisdictions' prisoners in available jail space.

Work Release & In Custody Work Crew Fees

Participants in the work release program pay 1% of their monthly gross wage for each day they work. The county receives a per diem per work release participant.

Electronic Home Monitor

Per day revenue received for inmates in the electronic home monitoring program.

Other Charges for Service

Represents income from various activities such as inmate concession sales, drug test fees, application and booking fees, meals provided to work release.

General Fund

Undedicated General Fund resources.

Operating Transfer In from Public Works

Funding from Public Works for three work crew supervisors to supervise inmate work crews for stream restoration and litter pickup.

Operating Transfer In from Admin Services

Funding from the Facilities division of Administrative Services for a Grounds Maintenance inmate work crew.

Contributions

Donations from Alcoa to provide funding for Alternative Corrections Work Crew.

Miscellaneous Revenues

Revenue generated by inmate phones and other small revenues from various sources.

Performance / Activity Measures

	Actual 2001	Actual 2002	Actual 2003	Projected 2004	Projected 2005	Projected 2006
Annual bookings	5,457	4,789	4,992	5,256	5,361	6,033
Average monthly bookings	455	399	416	438	446	503
Average annual bed days (Jail and Alternatives)	109,503	109,354	111,953	117,000	120,510	127,750
Average daily population (Main Jail)	227	236	240	246	253	275
Jail bed days diverted to Jail Alternative Programs	25,739	23,279	24,924	29,388	30,270	35,500
Work crews in the Jail Alternative Center	6	6	7	8	8	9
Inmate disturbances in the jail	45	67	45	55	45	40
Inmates seen by health care staff	2,796	3,000	3,144	3,695	3,954	4,231
Completion of classification on offenders booked in the jail	0	65%	85%	70%	80%	90%
Billing questions per month forwarded to the Admin. Lt. for correction	N/A	40	50	60	25	5
One Day Offender programs	7	7	8	9	10	11
Average Length of Stay for offenders (days)	20.7	24.08	23.48	23.9	20	18.5

Expenditures Summary

	Actual 2001	Actual 2002	Actual 2003	Budget 2004	Budget 2005	Budget 2006
GENERAL FUND						
1800 Courthouse Jail						
Salaries & Wages	2,247,486	2,275,178	2,257,920	2,108,873	2,140,454	2,177,634
Benefits	636,376	591,733	628,327	618,396	741,051	819,502
Supplies	73,256	100,123	87,096	95,360	177,228	152,170
Other Services & Charges	879,075	947,920	993,618	664,423	636,447	634,258
Capital Outlay	1,266	-	185,452	53,130	43,340	48,000
Operating Transfers	65,149	444,093	1,600	4,815	67,815	19,815
Residual Equity Transfers	-	-	-	-	8,000	-
Total Courthouse Jail	3,902,608	4,359,047	4,154,013	3,544,997	3,814,335	3,851,379
<i>Percent Change from Previous Year</i>	11.2%	11.7%	-4.7%	-14.7%	7.6%	1.0%
1810 Point Roberts Jail						
Supplies	-	-	-	150	-	-
Other Services & Charges	23,917	28,527	30,055	26,507	-	-
Total Point Roberts Jail	23,917	28,527	30,055	26,657	-	-
<i>Percent Change from Previous Year</i>	3.8%	19.3%	5.4%	-11.3%	-100.0%	0.0%
1815 Jail Administration						
Salaries & Wages	-	-	-	320,860	328,948	339,175
Benefits	-	-	-	85,374	103,308	115,470
Other Services & Charges	-	-	-	330,955	390,601	402,298
Total Jail Administration	-	-	-	737,189	822,857	856,943
<i>Percent Change from Previous Year</i>	0.0%	0.0%	0.0%	0.0%	11.6%	4.1%
1820 Off Site Work Release						
Salaries & Wages	-	-	-	51,610	50,672	50,032
Benefits	-	-	-	14,651	17,003	18,696
Supplies	-	-	39	600	600	600
Other Services & Charges	406,448	444,567	478,614	497,495	506,073	506,073
Total Off Site Work Release	406,448	444,567	478,653	564,356	574,348	575,401
<i>Percent Change from Previous Year</i>	1.7%	9.4%	7.7%	17.9%	1.8%	0.2%
1840 Alternative Corrections - Admin						
Salaries & Wages	388,961	426,665	283,794	122,702	111,016	111,136
Benefits	154,557	134,284	78,447	31,339	36,235	39,977
Supplies	37,848	43,959	29,042	34,500	36,200	36,200
Other Services & Charges	181,355	223,333	95,966	106,007	83,951	83,951
Capital Outlay	6,105	-	-	-	-	-
Operating Transfers	5,057	-	-	-	-	-
Total Alternative Corrections	773,883	828,241	487,249	294,548	267,402	271,264
<i>Percent Change from Previous Year</i>	13.9%	7.0%	-41.2%	-39.5%	-9.2%	1.4%

continued on next page

Expenditures Summary continued

	Actual 2001	Actual 2002	Actual 2003	Budget 2004	Budget 2005	Budget 2006
1842 Alternative Corrections - Work Crew						
Salaries & Wages	-	-	181,824	235,618	276,296	289,714
Benefits	-	-	72,285	78,188	121,769	134,008
Supplies	-	-	16,292	15,098	19,792	17,858
Other Services & Charges	-	-	60,970	58,400	64,000	63,000
Capital Outlay	-	-	2,164	-	-	-
<i>Total Alt Corrections-Work Crew</i>	-	-	333,535	387,304	481,857	504,580
<i>Percent Change from Previous Year</i>	0.0%	0.0%	0.0%	16.1%	24.4%	4.7%
1843 Forest Service Work Crew						
Salaries & Wages	-	-	23,500	39,212	40,683	43,088
Benefits	-	-	9,094	17,097	18,402	20,333
Supplies	-	-	7,399	13,714	9,277	5,705
Other Services & Charges	-	-	4,142	11,875	8,515	8,540
Capital Outlay	-	-	16,093	5,737	11,300	-
<i>Total Forest Service Work Crew</i>	-	-	60,228	87,635	88,177	77,666
<i>Percent Change from Previous Year</i>	0.0%	0.0%	0.0%	45.5%	0.6%	-11.9%
1845 Alternative Corrections - EHD						
Salaries & Wages	-	-	-	51,903	54,112	54,172
Benefits	-	-	-	14,681	17,172	18,889
Other Services & Charges	-	-	56,782	80,000	59,723	65,374
<i>Total Alt Corrections - EHD</i>	-	-	56,782	146,584	131,007	138,435
<i>Percent Change from Previous Year</i>	0.0%	0.0%	0.0%	158.2%	-10.6%	5.7%
1847 One Day Offender						
Salaries & Wages	-	-	-	8,000	6,975	6,975
<i>Total One Day Offender</i>	-	-	-	8,000	6,975	6,975
<i>Percent Change from Previous Year</i>	0.0%	0.0%	0.0%	0.0%	-12.8%	0.0%
1850 Jail Kitchen						
Salaries & Wages	8,882	-	-	-	-	-
Benefits	2,972	-	-	-	-	-
Supplies	15,644	21,272	33,982	27,266	16,000	16,000
Other Services & Charges	372,974	419,919	411,308	391,993	353,022	365,821
Capital Outlay	10,724	-	16,451	43,000	6,500	2,000
Operating Transfers	1,501	-	-	-	-	-
<i>Total Jail Kitchen</i>	412,697	441,191	461,741	462,259	375,522	383,821
<i>Percent Change from Previous Year</i>	-5.3%	6.9%	4.7%	0.1%	-18.8%	2.2%

continued on next page

Expenditures Summary continued

	Actual 2001	Actual 2002	Actual 2003	Budget 2004	Budget 2005	Budget 2006
1860 Jail Medical						
Salaries & Wages	26,254	27,846	28,865	32,056	34,627	36,744
Benefits	11,637	10,055	10,757	11,300	13,010	14,693
Supplies	141,313	174,250	178,698	248,518	227,078	241,078
Other Services & Charges	517,728	528,724	651,203	746,096	773,909	775,077
Capital Outlay	-	5,687	-	-	-	-
Operating Transfers	42,343	42,000	42,000	42,000	42,000	42,000
<i>Total Jail Medical</i>	<i>739,275</i>	<i>788,562</i>	<i>911,523</i>	<i>1,079,970</i>	<i>1,090,624</i>	<i>1,109,592</i>
<i>Percent Change from Previous Year</i>	<i>8.4%</i>	<i>6.7%</i>	<i>15.6%</i>	<i>18.5%</i>	<i>1.0%</i>	<i>1.7%</i>
1870 Jail Commissary						
Salaries & Wages	12,280	-	-	-	-	-
Benefits	3,494	-	-	-	-	-
Supplies	15,868	-	-	-	-	-
Operating Transfers	384	-	-	-	-	-
<i>Total Jail Commissary</i>	<i>32,026</i>	<i>-</i>	<i>-</i>	<i>-</i>	<i>-</i>	<i>-</i>
<i>Percent Change from Previous Year</i>	<i>0.0%</i>	<i>-100.0%</i>	<i>0.0%</i>	<i>0.0%</i>	<i>0.0%</i>	<i>0.0%</i>
1875 Peace Arch Rally						
Salaries & Wages	6,405	-	-	-	-	-
Benefits	911	-	-	-	-	-
<i>Total Peace Arch Rally</i>	<i>7,316</i>	<i>-</i>	<i>-</i>	<i>-</i>	<i>-</i>	<i>-</i>
<i>Percent Change from Previous Year</i>	<i>0.0%</i>	<i>-100.0%</i>	<i>0.0%</i>	<i>0.0%</i>	<i>0.0%</i>	<i>0.0%</i>
1880 North West Minichain						
Salaries & Wages	-	8	-	97,218	110,993	112,888
Benefits	-	1	-	28,716	33,442	36,997
Supplies	-	-	-	-	500	500
Other Services & Charges	-	-	-	30,600	40,200	40,200
<i>Total North West Minichain</i>	<i>-</i>	<i>9</i>	<i>-</i>	<i>156,534</i>	<i>185,135</i>	<i>190,585</i>
<i>Percent Change from Previous Year</i>	<i>0.0%</i>	<i>0.0%</i>	<i>-100.0%</i>	<i>0.0%</i>	<i>18.3%</i>	<i>2.9%</i>
<i>TOTAL JAIL</i>	<i>6,298,170</i>	<i>6,890,144</i>	<i>6,973,779</i>	<i>7,496,033</i>	<i>7,838,239</i>	<i>7,966,641</i>
<i>Percent Change from Previous Year</i>	<i>9.9%</i>	<i>9.4%</i>	<i>1.2%</i>	<i>7.5%</i>	<i>4.6%</i>	<i>1.6%</i>

Services

Inmate Commissary

Through their commissary purchases, jail inmates are supplied with a variety of goods such as toiletries, over the counter medications, snacks, packaged drinks, candy, clothing and stationery.

Prisoner Housing

Booking, inmate services, bail/fine receipt, release/transfer, court escorts, transportation, surveillance, laundry, correspondence, education programs, library, recreation, religious services, mail, visiting.

Telephone Service, Inmate

Provides telephone communication for inmates in jail.

Work Release

While on Work Release, offenders are allowed to work at their regular jobs to provide family support and pay bills. When they are not at work, offenders are housed in the contracted work release facility.

Drug Testing - Jail

Randomly screens work release, work program offenders and offenders on probation for drug or alcohol use to assure their compliance with program rules.

Work Crews, In and Out of Custody

Provides offender work crews and supervisors.

Electronic Home Monitoring

Program participants are outfitted with a monitoring unit that allows corrections staff to monitor inmates' movement. This allows the jail to have some degree of supervision over selected inmates who can satisfy court requirements without spending time in the main jail.

One Day Offender Program

A work/educational program for first time misdemeanor offenders.

Food Service

Provides three nutritionally balanced meals per day to inmates of the Whatcom County Jail, Whatcom County Juvenile Detention facility, Work Release and sack lunches for the Inmate Work Crews.

Inmate Medical

This service provides basic medical, dental and psychiatric care to jail inmates primarily through the use of contracted health care professionals.

Northwest Cooperative Transport

Transport prisoners between various jails from Bellingham to King County.

Superior Court / Superior Court Clerk's Office

Whatcom County's three Superior Court judges, three full time and two part time court commissioners hear all cases involving: adult felonies, all juvenile offenses, divorce, child custody, support matters, probate, guardianships, adoptions, property claims in excess of \$50,000, paternity actions, mental incompetency, abused or neglected children. The Court Clerk is custodian of all court records and accounts. This office also provides family law facilitation services, mandatory arbitration, public defender applications, domestic violence and anti-harassment protection orders.

FTE's for this department

Year	2001	2002	2003	*2004	*2005	*2006
FTE	33.00	33.00	33.00	34.70	35.70	32.00

**budget*

The chart below shows the organizational structure for 2005 only.

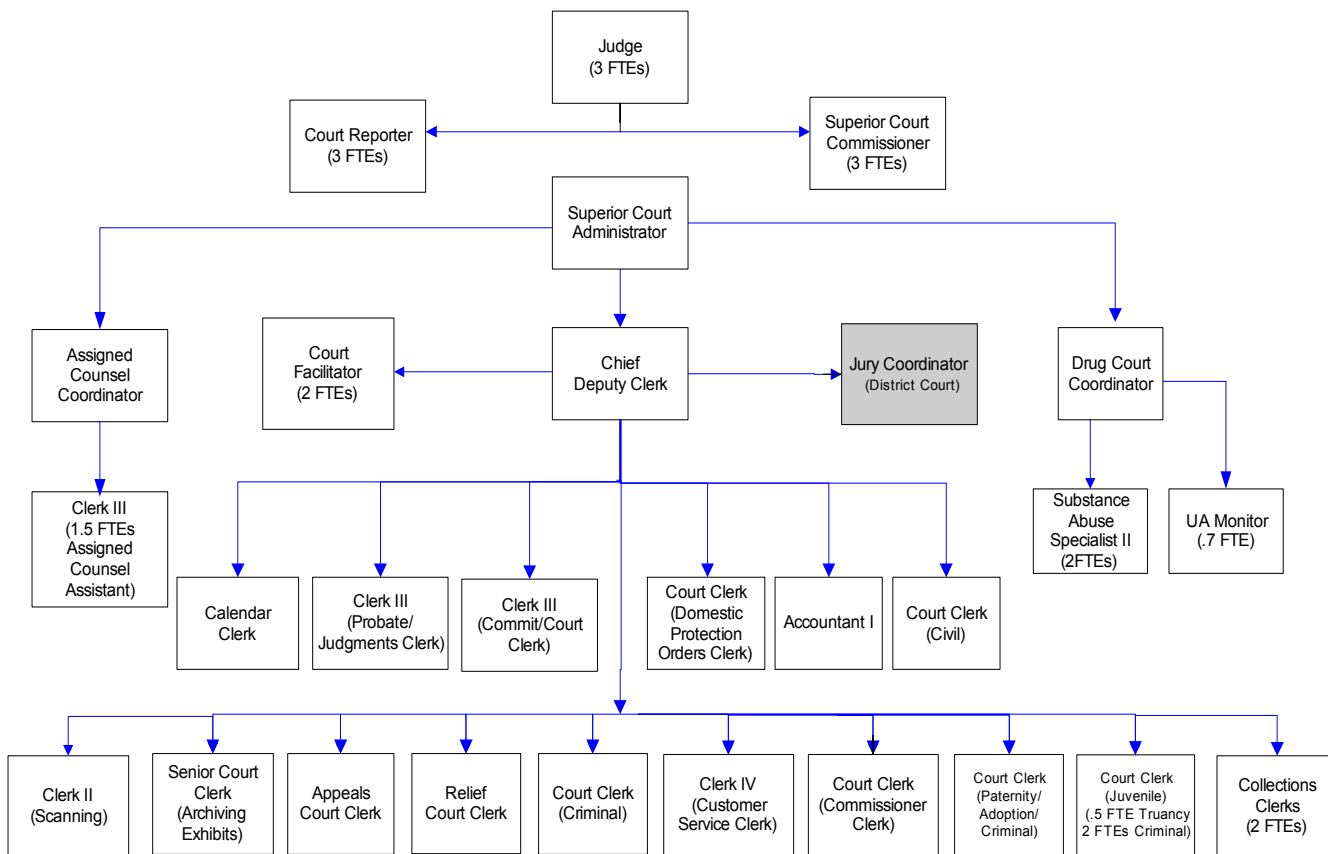

Mission & Objectives

Mission

The mission of the Superior Court, Assigned Counsel, County Clerk and Family Court Services is to improve the quality and the perception of the quality of justice in Whatcom County by identifying deficiencies in and implementing measures to improve:

- 1) Access to justice
- 2) Expedition and timeliness
- 3) Equality, fairness and integrity
- 4) Independence and accountability
- 5) Public trust and confidence

Objectives

- Implement at-the-time-of-receipt document imaging, replacing daily microfilming and end-of-case archival filming; simultaneous web posting of documents; providing access to electronic file folders to Prosecutor, Public Defender and public access terminals; employ automated distribution of certain orders/documents to Jail, DOC, WSP and other business partners.
- Institute parent-pay program for indigent defense costs and costs of detention.
- Institute fee-for-service for Courthouse Facilitator consultations.
- Launch multi-county web posting of domestic violence protection orders.

Expenditure Trends

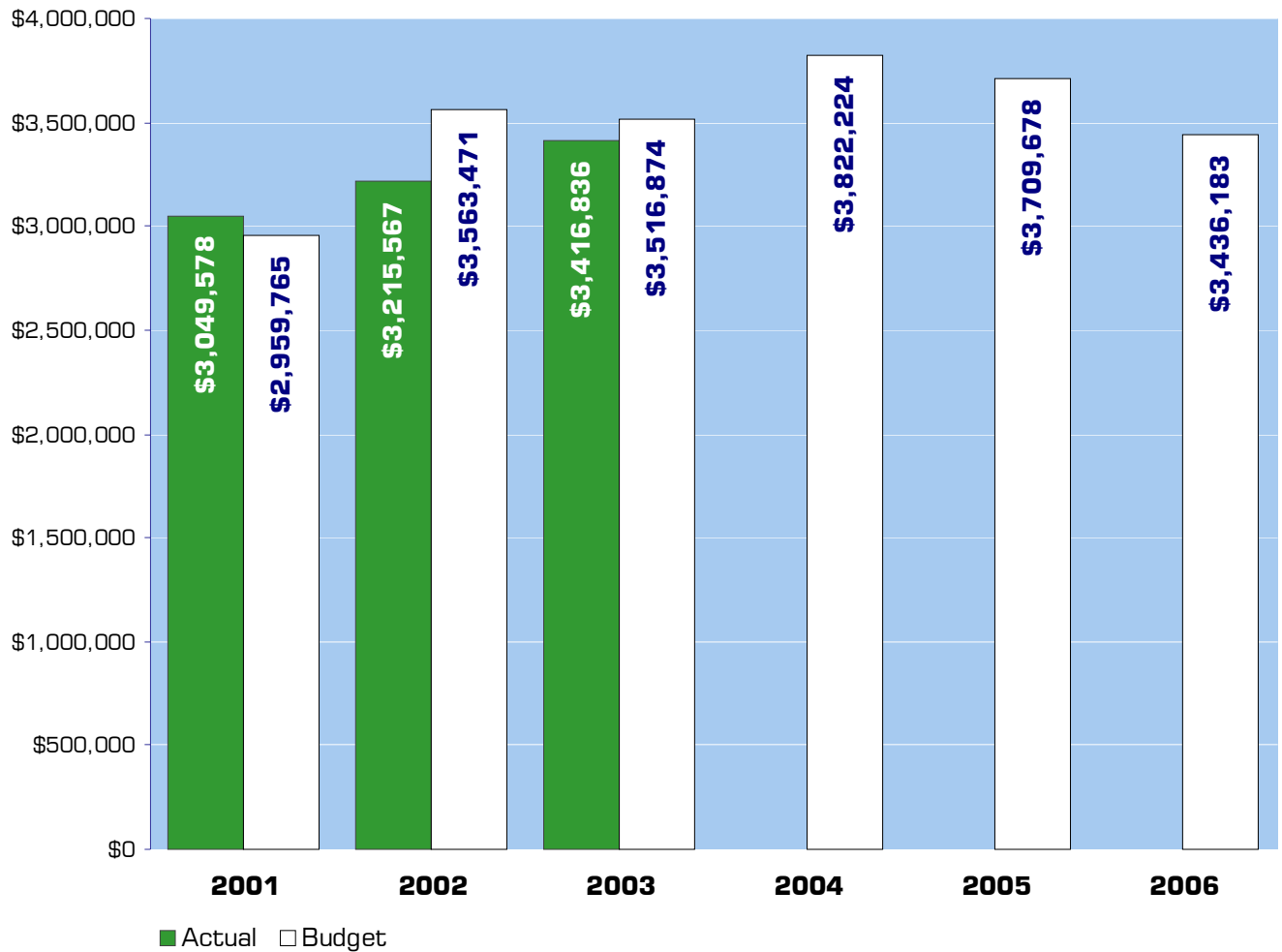

NOTE: Capital expenditures and interfund operating transfers are not shown to more accurately reflect ongoing operational costs.

2005-2006 Budget by Program

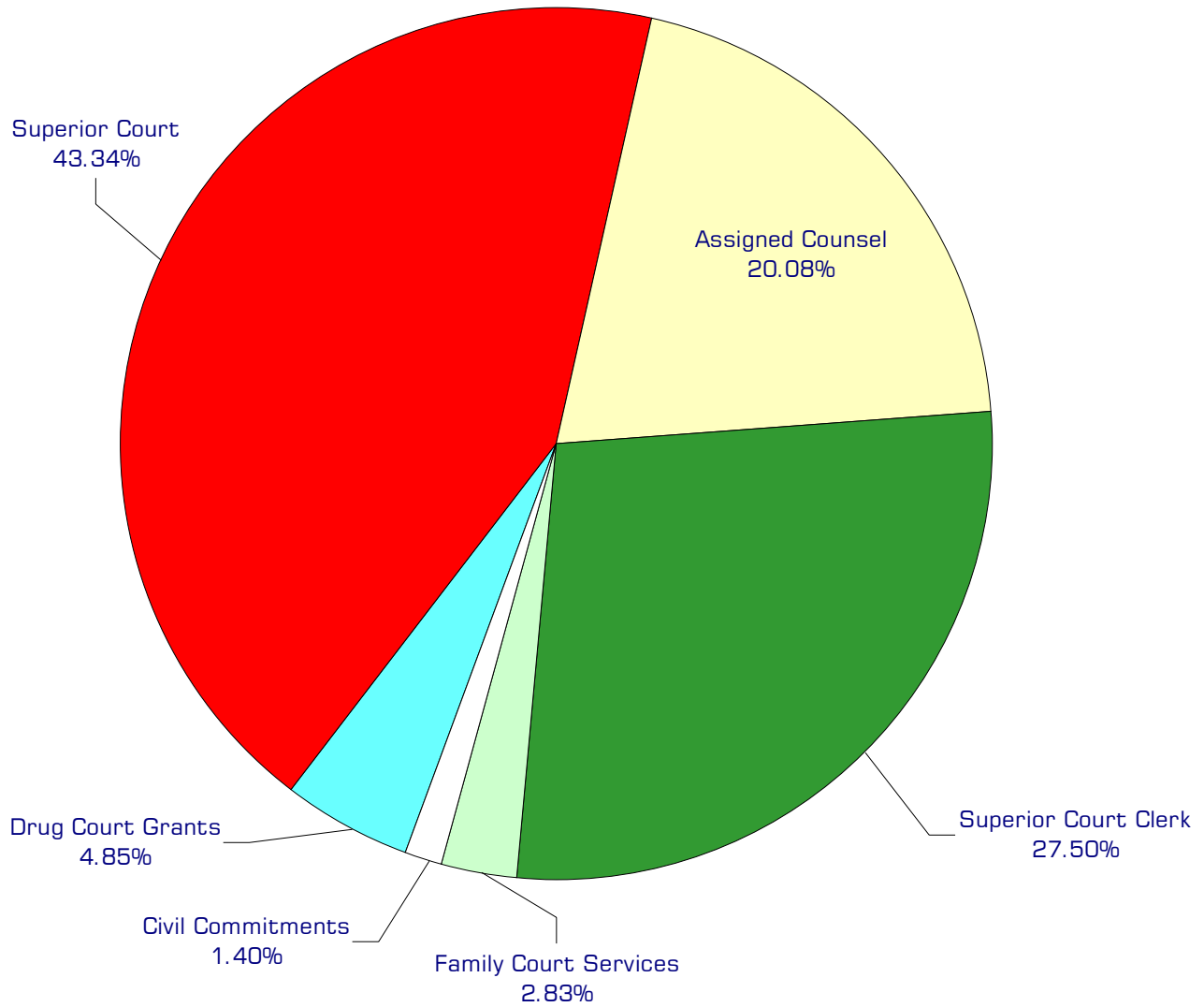

NOTE: Capital expenditures and interfund operating and residual equity transfers are not shown to more accurately reflect ongoing operational costs.

Program Summary

	Actual 2001	Actual 2002	Actual 2003	Budget 2004	Budget 2005	Budget 2006
OPERATIONS						
General Fund						
3100 Superior Court	1,418,190	1,469,405	1,445,658	1,552,123	1,534,046	1,562,850
3140 Assigned Counsel	662,534	646,147	679,019	790,825	714,549	720,463
3150 Superior Court Clerk	771,309	797,167	872,687	927,448	965,344	999,450
3160 Family Court Services	82,382	90,072	90,592	94,135	98,943	103,420
3170 Drug Courts Grant	110,256	199,073	317,079	407,693	346,796	-
3180 Civil Commitments	4,907	6,250	11,801	50,000	50,000	50,000
3190 STOP Grant	-	7,453	-	-	-	-
<i>Total Superior Court Operations</i>	3,049,578	3,215,567	3,416,836	3,822,224	3,709,678	3,436,183
CAPITAL						
General Fund						
3100 Superior Court	-	7,727	-	45,000	-	-
3150 Superior Court Clerk	1,559	-	-	-	-	-
3160 Family Court Services	2,296	-	-	-	-	-
3170 Drug Courts Grant	3,668	2,487	1,210	-	-	-
<i>Total Superior Court Capital</i>	7,523	10,214	1,210	45,000	-	-
TRANSFERS						
General Fund						
3100 Superior Court	6,707	-	-	-	-	-
3140 Assigned Counsel	1,082	-	-	-	-	-
3150 Superior Court Clerk	6,782	-	-	-	-	-
3160 Family Court Services	715	-	-	-	-	-
3170 Drug Court Grants	1,044	-	-	-	-	-
<i>Total Superior Court Transfers</i>	16,330	-	-	-	-	-
TOTAL SUPERIOR COURT	3,073,431	3,225,781	3,418,046	3,867,224	3,709,678	3,436,183
Percent Change from Previous Year	13.5%	5.0%	6.0%	13.1%	-4.1%	-7.4%

2005-2006 Funding Sources

	2005	2006
Intergovernmental Revenues	499,260	278,813
Charges for Services	295,000	280,000
Miscellaneous Revenues	20,000	20,000
General Fund	2,869,918	2,857,370
Operating Trans - Drug Fund	25,500	0
Total Funding	3,709,678	3,436,183

Intergovernmental Revenue

The court receives reimbursement, in the form of grants from the federal and state governments, for costs incurred in connection with Drug Court, civil commitment, juvenile actions, and child support enforcement.

Charges for Services

The Superior Court charges for filings and various other services. Judicial fines and forfeits are not included as Superior Court revenue.

Miscellaneous Revenues

The Superior Court collects a surcharge on marriage licenses, as well as revenue from other miscellaneous sources.

General Fund

Undedicated General Fund resources.

Operating Transfer In - Drug Fund

To provide funding assistance to the Superior Court Drug Court Program.

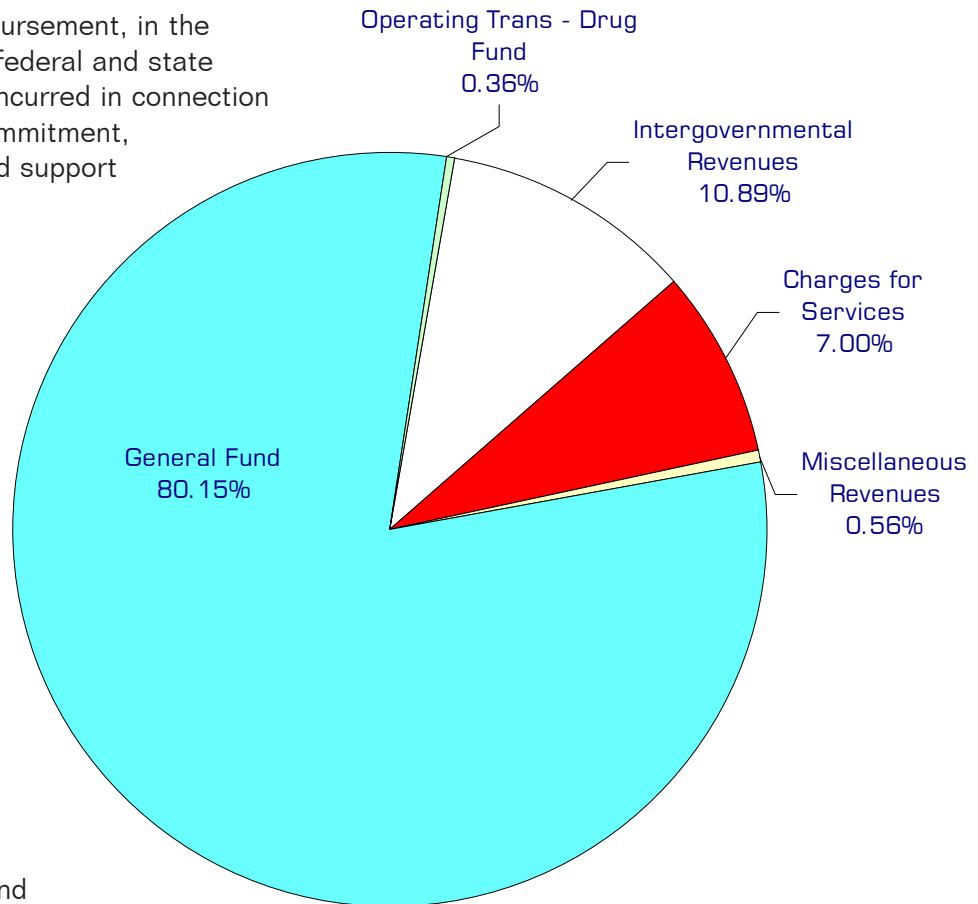

Performance / Activity Measures

	Actual 2001	Actual 2002	Actual 2003	Projected 2004	Projected 2005	Projected 2006
Hearings/trials per year	17,120	17,809	18,017	19,472	20,056	20,658
Time to trial once ready, civil	6-12 months	6-12 months	6-12 months	6-12 months	6-12 months	6-12 months
Facilitator contacts	Unavailable	5,500	5,800	5,800	5,000	5,000
Pages in microfilm inventory	10,500,000	11,159,000	11,759,124	12,259,124	13,150,000	13,239,000
Cases filed	9,642	10,573	11,569	12,565	13,531	14,497
Documents filed	181,588	186,236	194,726	199,396	207,886	216,376
Computer records entered	1,308,406	1,334,593	1,342,133	1,448,514	1,554,895	1,661,276
Arbitrations filed	51	49	52	70	73	76
District Court AH & DV petitions filed	431	487	593	699	805	911
Superior Court AH & DV petitions filed	269	252	287	318	353	388
Assigned Counsel/contacts in jail	4,473	3,606	3,667	3,780	3,841	3,902
Assigned Counsel/applications denied	893	941	795	722	795	800
Assigned Counsel/cases conflicted out	390	357	348	378	408	438
JIS DV data entry (new cases/not TRO's)	687	647	681	690	715	749
Domestic mandatory mediations heard	64	66	71	86	91	96
Domestic settlement conferences heard	70	89	83	110	110	120
Dependency Guardian ad Litem appointments	382	303	331	540	441	461
Domestic trials	121	124	131	136	141	146
Files checked out/in	64,273	68,981	70,416	72,547	74,678	76,809
Protection Orders Scanned to Web (eff. July/03)			656 (1/2 yr)	1,458	1,604	1,750

Expenditures Summary

	Actual 2001	Actual 2002	Actual 2003	Budget 2004	Budget 2005	Budget 2006
GENERAL FUND						
3100 Superior Court						
Salaries & Wages	776,044	826,576	825,122	836,651	837,554	837,913
Benefits	153,081	120,864	115,156	130,195	146,064	162,025
Supplies	7,185	9,859	10,474	5,500	5,500	5,500
Other Services & Charges	481,880	512,106	494,906	579,777	544,928	557,412
Capital Outlay	-	7,727	-	45,000	-	-
Operating Transfers	6,707	-	-	-	-	-
<i>Total Superior Court</i>	<i>1,424,897</i>	<i>1,477,132</i>	<i>1,445,658</i>	<i>1,597,123</i>	<i>1,534,046</i>	<i>1,562,850</i>
<i>Percent Change from Previous Year</i>	<i>5.1%</i>	<i>3.7%</i>	<i>-2.1%</i>	<i>10.5%</i>	<i>-3.9%</i>	<i>1.9%</i>
3140 Assigned Counsel						
Salaries & Wages	82,619	88,341	100,554	114,239	100,291	102,035
Benefits	27,726	28,265	29,603	34,744	39,027	43,199
Supplies	-	129	136	1,500	1,500	1,500
Other Services & Charges	552,189	529,412	548,726	640,342	573,731	573,729
Operating Transfers	1,082	-	-	-	-	-
<i>Total Assigned Counsel</i>	<i>663,616</i>	<i>646,147</i>	<i>679,019</i>	<i>790,825</i>	<i>714,549</i>	<i>720,463</i>
<i>Percent Change from Previous Year</i>	<i>32.4%</i>	<i>-2.6%</i>	<i>5.1%</i>	<i>16.5%</i>	<i>-9.6%</i>	<i>0.8%</i>
3150 Superior Court Clerk						
Salaries & Wages	517,627	528,035	581,035	611,410	618,336	626,563
Benefits	153,675	158,443	181,133	204,049	232,608	258,487
Supplies	24,422	27,394	27,744	23,000	23,000	23,000
Other Services & Charges	75,585	83,295	82,775	88,989	91,400	91,400
Capital Outlay	1,559	-	-	-	-	-
Operating Transfers	6,782	-	-	-	-	-
<i>Total Superior Court Clerk</i>	<i>779,650</i>	<i>797,167</i>	<i>872,687</i>	<i>927,448</i>	<i>965,344</i>	<i>999,450</i>
<i>Percent Change from Previous Year</i>	<i>6.5%</i>	<i>2.2%</i>	<i>9.5%</i>	<i>6.3%</i>	<i>4.1%</i>	<i>3.5%</i>
3160 Family Court Services						
Salaries & Wages	48,800	63,010	69,664	71,174	72,813	74,235
Benefits	13,970	18,806	20,861	22,961	26,130	29,185
Supplies	2,234	-	67	-	-	-
Other Services & Charges	17,378	8,256	-	-	-	-
Capital Outlay	2,296	-	-	-	-	-
Operating Transfers	715	-	-	-	-	-
<i>Total Family Court Svcs</i>	<i>85,393</i>	<i>90,072</i>	<i>90,592</i>	<i>94,135</i>	<i>98,943</i>	<i>103,420</i>
<i>Percent Change from Previous Year</i>	<i>97.8%</i>	<i>5.5%</i>	<i>0.6%</i>	<i>3.9%</i>	<i>5.1%</i>	<i>4.5%</i>

continued on next page

Expenditures Summary continued

	Actual 2001	Actual 2002	Actual 2003	Budget 2004	Budget 2005	Budget 2006
3170 Drug Courts Grant						
Salaries & Wages	69,403	87,770	133,424	164,933	146,815	-
Benefits	18,479	22,696	37,320	48,420	53,391	-
Supplies	2,386	4,734	6,294	10,000	1,000	-
Other Services & Charges	19,988	83,873	140,041	184,340	145,590	-
Capital Outlay	3,668	2,487	1,210	-	-	-
Operating Transfers	1,044	-	-	-	-	-
<i>Total Drug Courts Grant</i>	114,968	201,560	318,289	407,693	346,796	-
<i>Percent Change from Previous Year</i>	6410.1%	75.3%	57.9%	28.1%	-14.9%	-100.0%
3180 Civil Commitments						
Other Services & Charges	4,907	6,250	11,801	50,000	50,000	50,000
<i>Total Drug Courts Grant</i>	4,907	6,250	11,801	50,000	50,000	50,000
<i>Percent Change from Previous Year</i>	-93.5%	27.4%	88.8%	323.7%	0.0%	0.0%
3190 STOP Grant						
Supplies	-	57	-	-	-	-
Other Services & Charges	-	7,396	-	-	-	-
<i>Total STOP Grant</i>	-	7,453	-	-	-	-
<i>Percent Change from Previous Year</i>	0.0%	0.0%	-100.0%	0.0%	0.0%	0.0%
TOTAL SUPERIOR COURT	3,073,431	3,225,781	3,418,046	3,867,224	3,709,678	3,436,183
<i>Percent Change from Previous Year</i>	13.5%	5.0%	6.0%	13.1%	-4.1%	-7.4%

Services

Adult Drug Court

Intensive case management and monitoring of long-term drug users, involving treatment and reward and punishment.

Becca Cases (Truancy/CHINS/At-Risk)

Youthful offender programs, to modify incipient criminal behaviors.

Court Computer Management

Management of 30+ PC's and printers; involving the automation of business practices and interactivity with other law and justice agencies; liaison between local and state IS offices.

Court Interpretation

Arrange for in-court foreign language and American Sign Language interpreter services, maintain library of certified and qualified interpreters and coordinate services with other offices and agencies.

Dispute Resolution Center

Provide family law dispute resolution services and small claims dispute resolution.

Family Drug Court

Case management for drug using parents in dependency cases.

Guardians ad Litem

Provide court ordered independent investigations regarding alleged incompetents, abused children and children whose parents are in dispute.

Jury Administration

Summons 24,000 jurors per year. (80% for Superior Court, 20% District Court)

Juvenile Drug Court

Intensive case management of juvenile drug users, providing treatment and life skills.

Mandatory Mediation

In domestic relations cases certain matters MUST be mediated before the parties may come to court. These matters include property, custody and visitation.

Public Education

Provide for public education.

Settlement Conferences

The requirement that parties must attend a settlement conference presided over by a judicial officer, with the intent that parties may be induced to settle cases based on predicted trial outcomes.

Teen Court

Alternative to criminal case, where youthful offender is tried by peers, with peers acting as attorneys, court staff and jury.

Services continued

Assigned Counsel

Provide indigency screening, Superior/District Court's criminal actions, parents in dependencies, alleged incompetents, juveniles, GAL applicants and conflict counsel.

Domestic Violence

Provide protection order processing for both Superior and District Courts, domestic violence and antiharassments and training satellite processors at Crisis Center.

Mandatory Arbitration

Provide arbitration for certain civil cases with limited amounts in dispute. Maintain strike-list of 47 arbitrators.

Appeals

Criminal and civil appeals to Court of Appeals and Supreme Court, appeals from District and Municipal Courts and administrative agencies.

Archiving Records Management

The microfilming, preservation and transfer of approximately 400,000 pages of case files annually, under direction of the Secretary of State.

Bar Code File Tracking (CRIMS)

Infrared scanning program for file folder tracking.

Calendar Scheduling

Scheduling of approximately 20,000 hearings and trials per year.

Change of Venue

The certification and forwarding of complete files to sister counties pursuant to a court order.

Civil Cases

Index and file documents, temporary orders, preliminary hearings, trials, supplemental examinations, garnishments and foreclosures, trust accounting and respond to phone and mail research requests.

Collections

Contractual commercial collections for delinquent payment of adult criminal and juvenile legal financial obligations.

Counter/Phone Reception Customer Service

Full service customer service and phone reception, with on-line research ability.

Criminal Cases

Services include indexing and filing documents, probable cause determinations, first appearances, preliminary hearings, trials, sentencing, issuing warrants of arrest, certifying and mailing J&S's weekly, responding to research requests, taking fingerprints, probation violations, collecting and disbursing restitution/fines.

Services continued

Document search for Office of Support Enforcement

File research and faxing of documents for collection purposes to state office.

Domestic Relations

Index and file documents; respond to phone and mail research requests, temporary orders, preliminary hearings, trials, support, custody and visitation modification, contempt actions, copying tapes of proceedings and preparing monthly DSHS report.

Domestic Violence Data Entry

Parties information entry in statewide database of protection orders.

Exhibit Management

Catalog and monitor release of exhibits, transfer to archives, monitor for hazards, coordinate destruction and/or return.

Grant and Cost Reimbursement Agreement Tracking/Accounting

Record, monitor and submit grant and interlocal agreement financial tracking for JAIBG Grant, Drug Court Grant, Support Enforcement Grant and WAC civil commitment costs.

Involuntary Commitments

For involuntary mental health commitments, provide indexing and filing of documents, respond to research requests. Hearings and trials at hospital courtroom.

Issuance of Warrants

Timely issue arrest warrants and bench warrants.

Judgments

Index and file documents, respond to research requests. Provide official index of all debts reduced to enforceable judgment, entry required within 24 hours and partial and full satisfaction of judgments.

Juvenile Dependency

Provide indexing and filing of documents, and research requests. Attorney General-filed cases of reabused or neglected children, 6-month reviews until 18; hearings and trials.

Juvenile Offenders

Provide indexing and filing of documents, respond to research requests, first appearances, hearings, trials and probation violations.

Paternity & Adoptions

Index and file documents, respond to research requests, generate notices, hearings, trials, monitor sealed and unsealed portions of files.

Probate & Guardianship

Index and file documents; respond to phone and mail research requests; estate settlement; guardianship monitoring; hearings; trials; issuing Form K's; Letters Testamentary/Administration.

Services continued

Restitution and Probation Accounting

Provide accounting services to receipt \$250,000 monthly, bank deposits, restitution disbursements, manage investment accounts for minors, payroll, accounts payable and accounts receivable.

Specialized/Confidential Record Tracking

Limited access topics received/indexed/filed confidentially: including one-party wiretap consents, special inquiry proceedings and search warrants.

Time-Pay, Criminal Legal Financial Obligations

Contractual commercial installment payment services for criminal defendants ordered to pay financial obligations.

Web Posting -Domestic Violence Orders

Scan/post to web domestic violence protection orders.

Family Law Courthouse Facilitator

Provide assistance with domestic relations matters for those without attorneys. Clerk is required to provide assistance and the use of a Facilitator is optional.



County Treasurer's Office

An elected official, the County Treasurer collects taxes, reports, invests and manages all monies and debt for Whatcom County and all other junior and special purpose districts. This office provides banking services to the organization; forecloses on property for delinquent taxes; maintains an inventory of county-owned property; conducts property sales.

FTE's for this department

Year	2001	2002	2003	*2004	*2005	*2006	*budget
FTE	15.50	15.50	15.50	16.00	16.00	16.00	

The chart below shows the organizational structure for 2005 only.

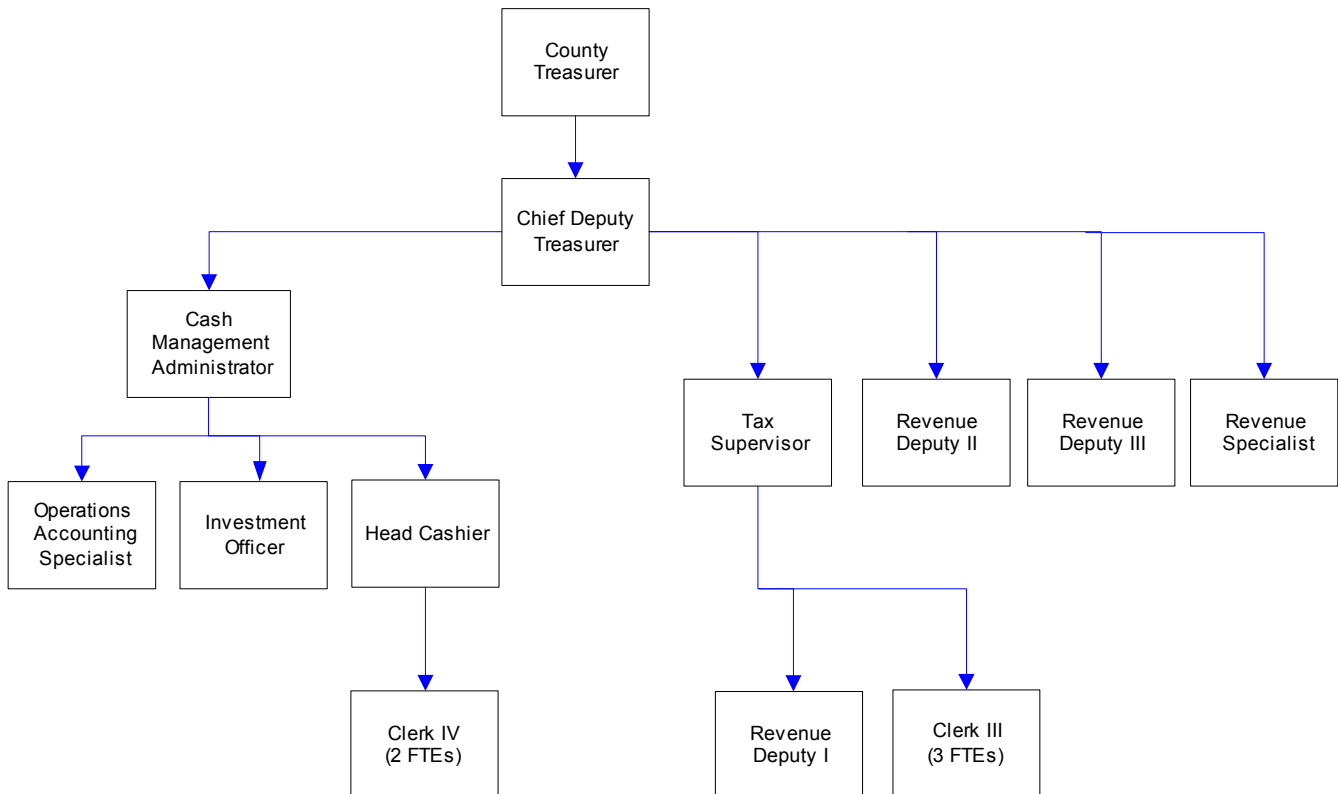

Mission & Objectives

Mission

Efficiently and effectively collect, report, invest, and manage all monies and debt for Whatcom County and all other junior and special purpose districts. Provide exemplary service to all of our customers by being responsive, courteous, and knowledgeable.

Objectives

- Mail tax statements by February 14th.
- Deposit all funds received from districts and departments within 24 hours.
- Collect 97% of current year tax receivables.
- Conduct and train county cash handlers bi-annually.
- Deliver financial reports to all departments and districts by the 10th business day each month.
- Deposit checks received in amounts of \$100,000 or more the same day received.
- Complete processing of tax payments within five working days of deadline.
- Train 25% of the department heads or elected officials and their supervisor(s) responsible for cash handlers regarding cash handling policies and procedures.

Expenditure Trends

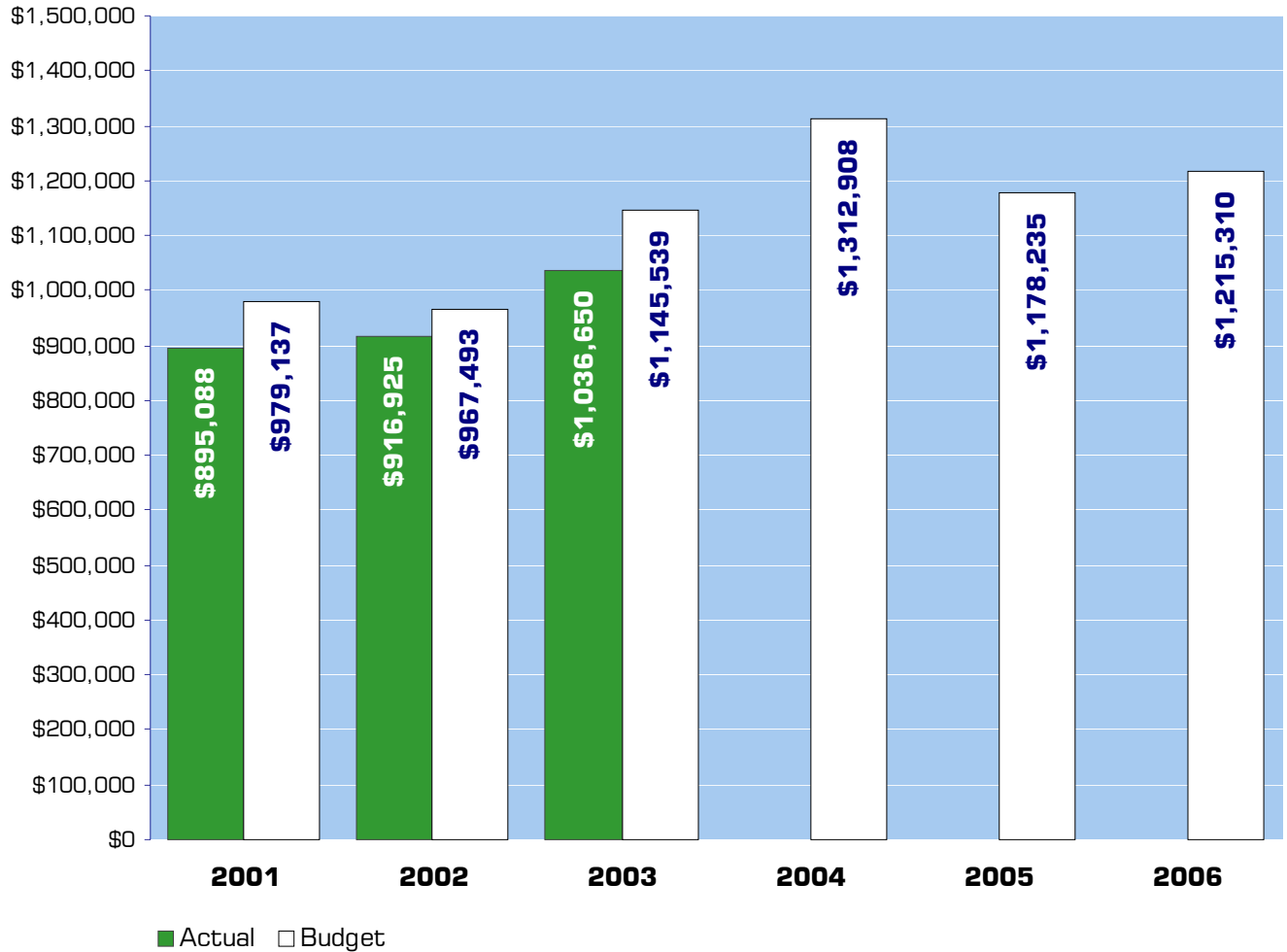

NOTE: Capital expenditures and interfund operating transfers are not shown to more accurately reflect ongoing operational costs.

2005-2006 Budget by Program

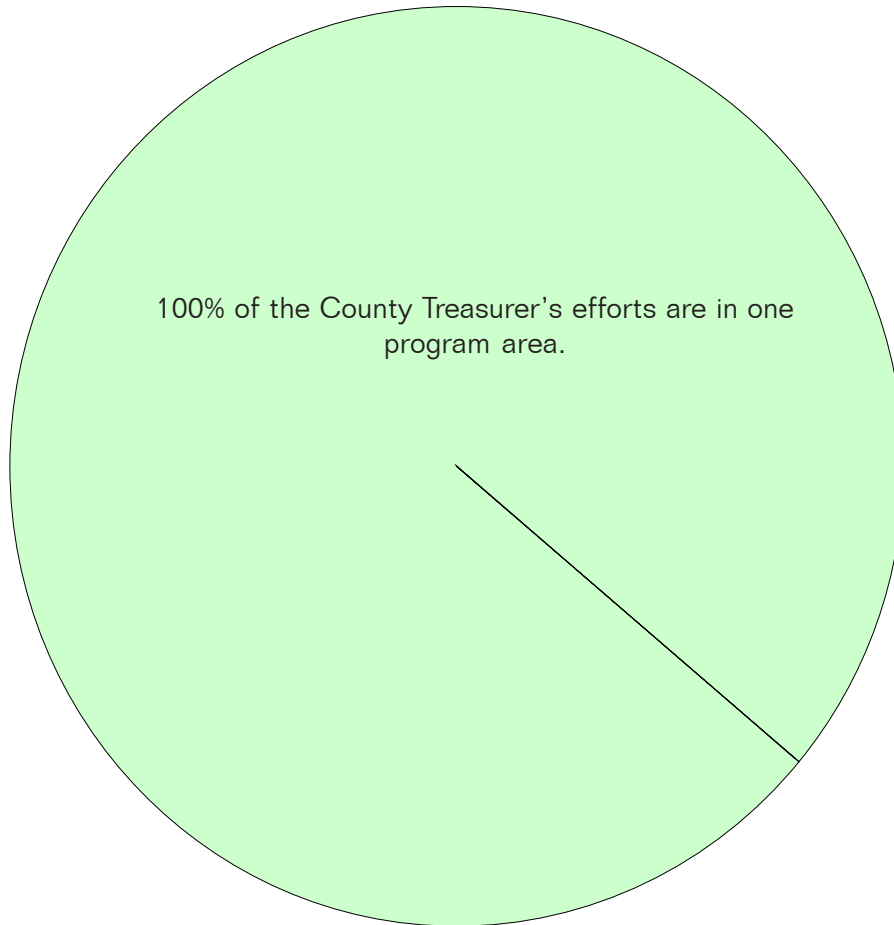

NOTE: Capital expenditures and interfund operating and residual equity transfers are not shown to more accurately reflect ongoing operational costs.

Program Summary

	Actual 2001	Actual 2002	Actual 2003	Budget 2004	Budget 2005	Budget 2006
OPERATIONS						
General Fund						
3300 Treasurer	895,088	916,925	1,036,650	1,312,908	1,178,235	1,215,310
<i>Total Treasurer Operations</i>	895,088	916,925	1,036,650	1,312,908	1,178,235	1,215,310
CAPITAL						
General Fund						
3300 Treasurer	2,849	-	-	-	-	-
<i>Total Treasurer Capital</i>	2,849	-	-	-	-	-
TRANSFERS						
General Fund						
3300 Treasurer	6,501	-	-	-	-	-
<i>Total Treasurer Transfers</i>	6,501	-	-	-	-	-
TOTAL TREASURER	904,438	916,925	1,036,650	1,312,908	1,178,235	1,215,310
<i>Percent Change from Previous Year</i>	2.0%	1.4%	13.1%	26.6%	-10.3%	3.1%

2005-2006 Funding Sources

	2005	2006
General Fund	1,094,519	1,110,794
Miscellaneous Revenues	83,716	104,516
Total Funding	1,178,235	1,215,310

General Fund

Undedicated General Fund resources.

Miscellaneous Revenue

The Treasurer collects small amounts of revenue from a variety of sources, such as charges on returned checks, tax collection fees, printing and duplicating charges and passport processing fees.

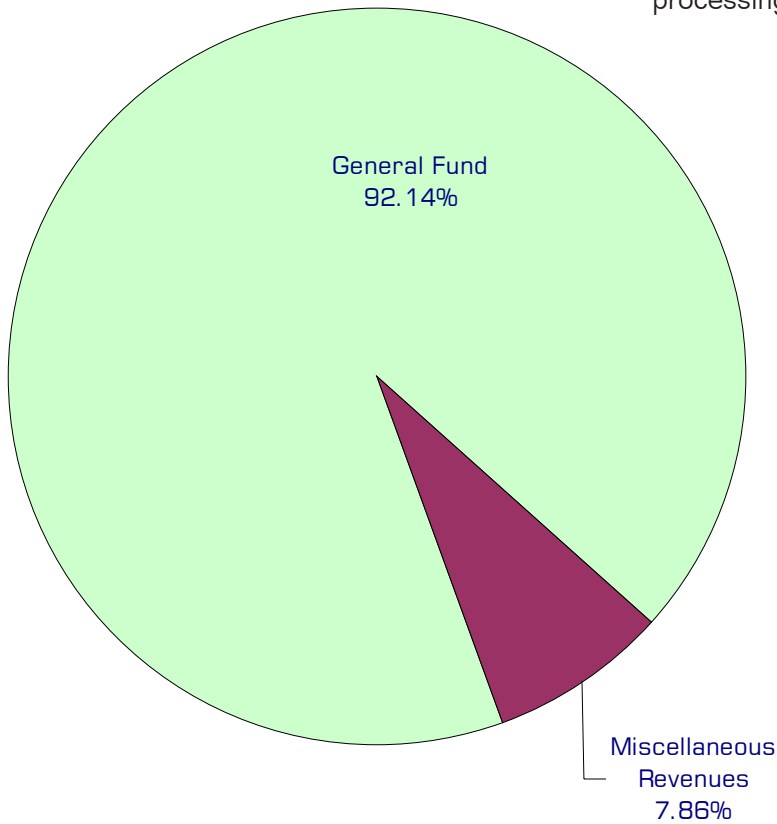

Performance / Activity Measures

	Actual 2001	Actual 2002	Actual 2003	Projected 2004	Projected 2005	Projected 2006
Financial Transaction Activity	\$1.5 billion	\$1.3 billion	\$1.4 billion	\$1.4 billion	\$1.5 billion	\$1.5 billion
Tax Collection Rate	96.9%	96.4%	96.9%	96.9%	96.7%	96.7%
Alternative payment options used	125,000	133,500	137,000	140,000	142,000	144,000
Bonds Redeemed	\$12,431,000	\$18,982,000	\$15,400,000	\$24,198,000	\$17,770,000	\$17,543,000
Bonds Issued	\$31,426,000	\$21,350,000	\$ 7,661,000	\$20,000,000	\$20,000,000	\$20,000,000
Foreclosure Parcels	341	209	130	122	200	200
Taxpayer & Address Changes	41,126	39,880	56,135	42,000	42,000	42,000
Cancellations & Supplementals	2,700	2,800	2,347	3,500	4,000	4,200
Miscellaneous Receipts	9,992	9,623	9,500	10,500	11,000	12,000
Segregations & Combinations	583	589	1,232	1,300	1,375	1,400
Refunds	2,002	1,681	2,068	2,000	2,000	2,000
Special Assessment Accounts	102,061	102,897	103,436	11,563	12,000	12,000
Tax Accounts	103,050	103,719	103,567	103,939	104,500	105,000
Excise Documents	9,992	11,300	13,139	12,500	12,000	12,000
Warrants Redeemed	95,210	94,100	90,000	89,000	88,000	87,000
Hours of Administrative Burden			750	1,000	750	500
Passport Applications				1,250	1,300	1,400

Expenditures Summary

	Actual 2001	Actual 2002	Actual 2003	Budget 2004	Budget 2005	Budget 2006
GENERAL FUND						
3300 Treasurer						
Salaries & Wages	455,943	468,719	530,935	584,027	593,002	603,577
Benefits	125,996	127,895	147,444	176,547	200,039	223,439
Supplies	21,865	14,064	12,713	41,990	23,117	20,617
Other Services & Charges	291,284	306,247	345,558	510,344	362,077	367,677
Capital Outlay	2,849	-	-	-	-	-
Operating Transfers	6,501	-	-	-	-	-
TOTAL TREASURER	904,438	916,925	1,036,650	1,312,908	1,178,235	1,215,310
<i>Percent Change from Previous Year</i>	2.0%	1.4%	13.1%	26.6%	-10.3%	3.1%

Services

Process Passport Applications for the Federal Department of State

The Treasurer's office is a certified passport agency. We process passport applications, making sure the form is completed properly, verifying identification documentation, and forward these applications to the Department of State for passport issuance.

Tax Administration and Collection

Billing, collection, receipting and distribution of all property taxes and special assessments for all taxing districts. Administration and collection of taxes under various state and local taxing authorities.

Financial Services

Provides investment portfolio management, cash management, debt management, financial reporting and reconciliation services.



Veteran's Relief

RCW 73.08.080 provides for a property tax to be levied at not less than one and one eighth cents per thousand dollars of assessed valuation for the care of indigent veterans and their families.

There are no FTE's in Veteran's Relief.

Mission & Objectives

Mission

Provide relief to eligible indigent veterans and their families.

Objectives

Provide financial assistance to veterans and their families for the following:

- Rent
- Utilities
- Telephone service when medically required or for work search
- Some medical costs
- Wood or propane for heating
- Food
- Clothing (on occasion)

Expenditure Trends

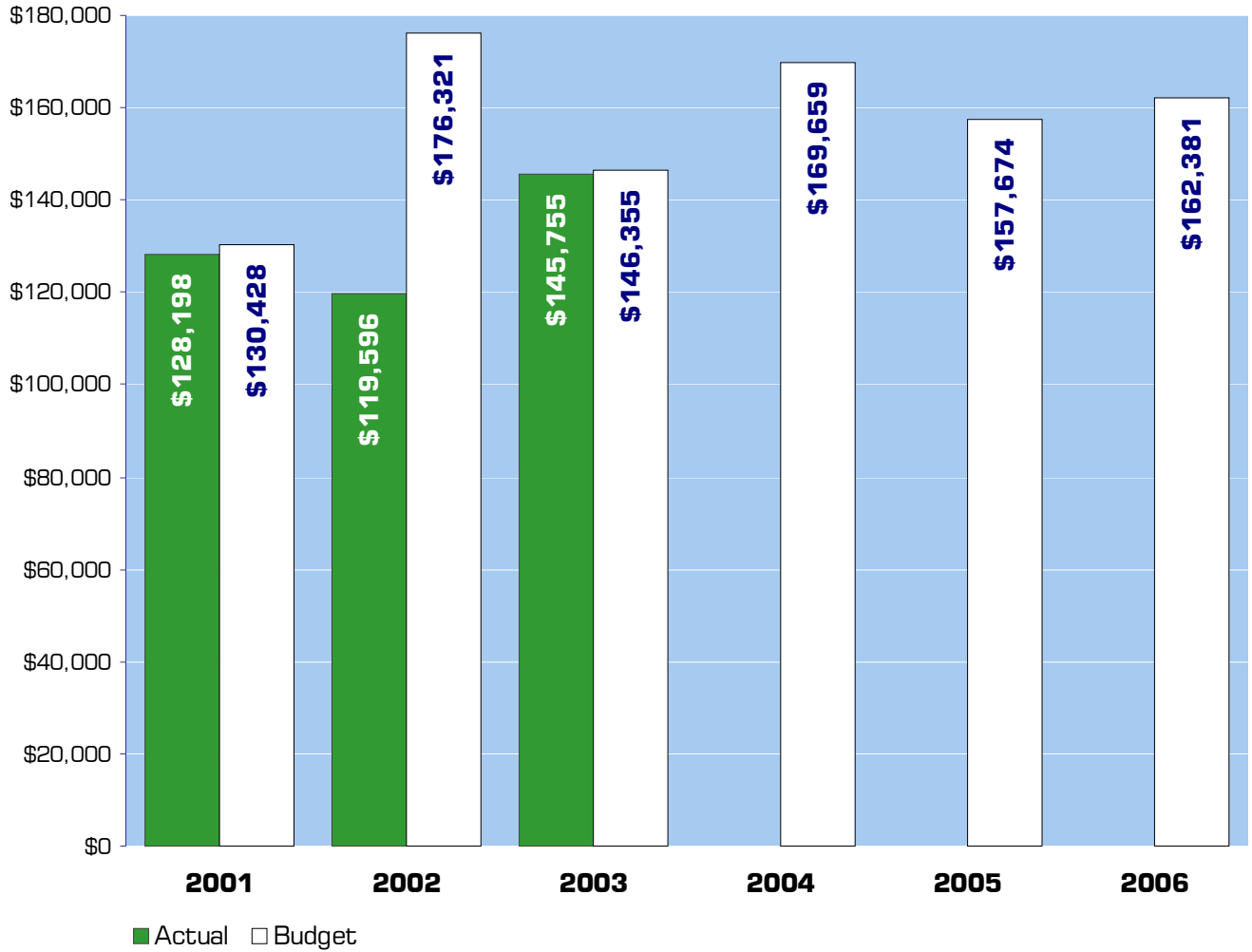

2005-2006 Budget by Program

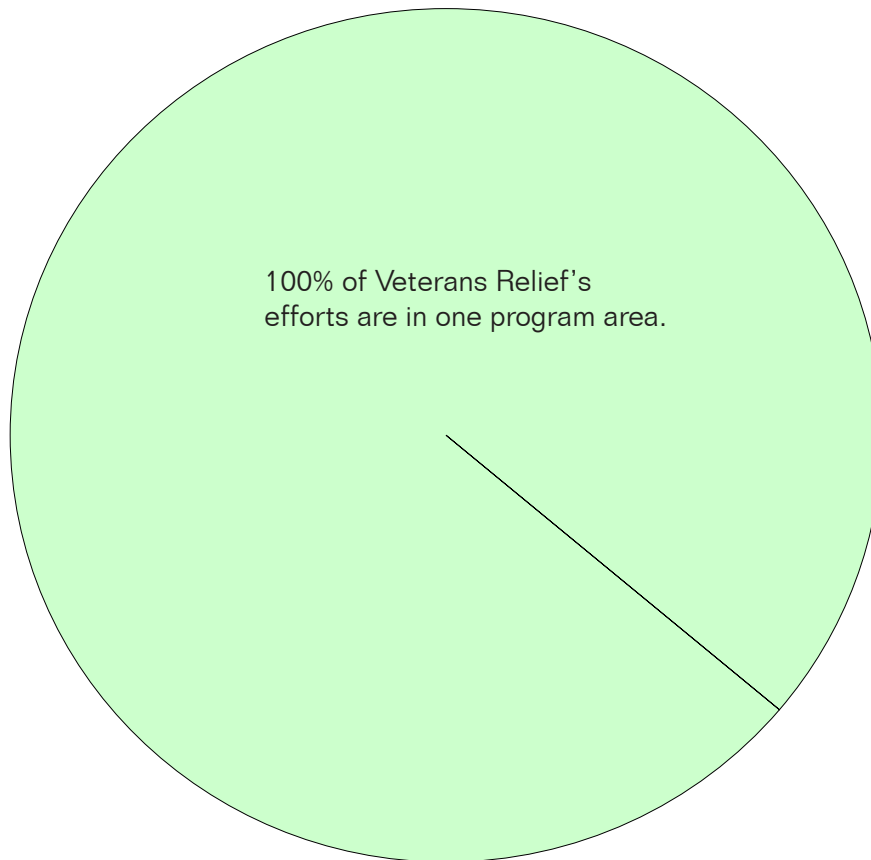

NOTE: Capital expenditures and interfund operating and residual equity transfers are not shown to more accurately reflect ongoing operational costs.

Program Summary

	Actual 2001	Actual 2002	Actual 2003	Budget 2004	Budget 2005	Budget 2006
OPERATIONS						
114 Veterans Relief Fund	128,198	119,596	145,755	169,659	157,674	162,381
<i>Total Veterans Relief Operations</i>	128,198	119,596	145,755	169,659	157,674	162,381
TOTAL VETERANS RELIEF	128,198	119,596	145,755	169,659	157,674	162,381
<i>Percent Change from Previous Year</i>	-0.1%	-6.7%	21.9%	16.4%	-7.1%	3.0%

2005-2006 Funding Sources

	2005	2006
Property Tax	151,826	156,478
Miscellaneous Revenue	5,848	5,903
Total Funding	157,674	162,381

Property Tax

RCW 73.08.080 provides for a property tax to be levied at not less than one and one eighth cents per thousand dollars of assessed valuation for the care of indigent veterans and their families.

Miscellaneous Revenues

State Forest Board revenues, which are distributed in the same proportion as property taxes.

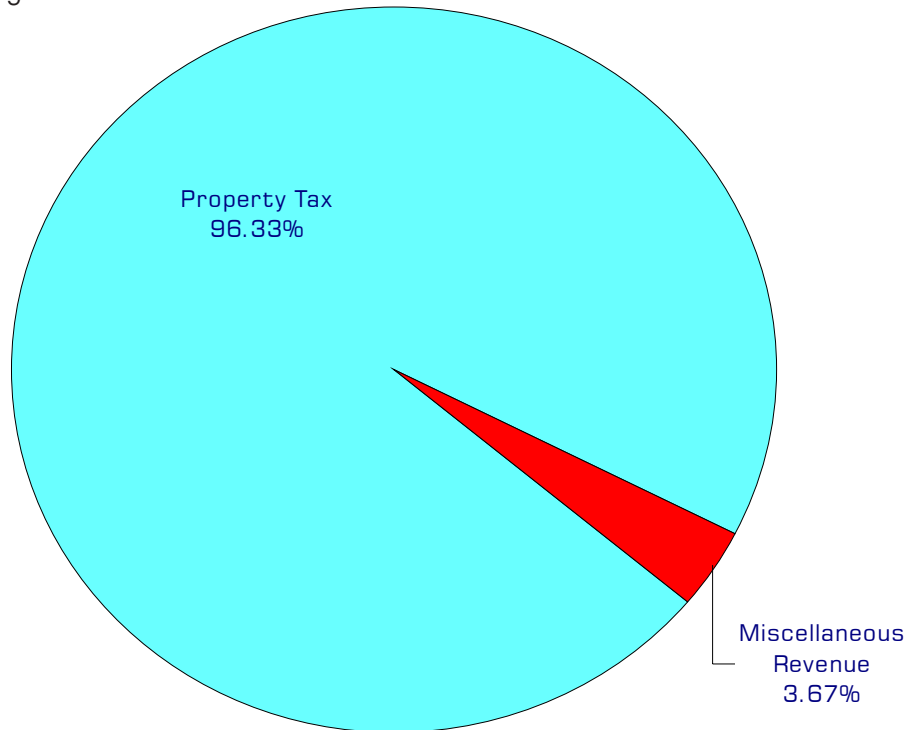

**Fund balance is not included in the above chart.*

Expenditures Summary

Actual 2001	Actual 2002	Actual 2003	Budget 2004	Budget 2005	Budget 2006
----------------	----------------	----------------	----------------	----------------	----------------

114 VETERANS RELIEF FUND

Veterans Relief						
Supplies	849	447	-	600	600	600
Other Services & Charges	127,349	119,149	145,755	169,059	157,074	161,781
<i>TOTAL VETERANS RELIEF</i>	128,198	119,596	145,755	169,659	157,674	162,381
<i>Percent Change from Previous Year</i>	-8.7%	-6.7%	21.9%	16.4%	-7.1%	3.0%

